

Garage Door Opener Models

139.18815 - 1/2 HP

139.18855 - 1/2 HP

139.18859 - 1/2 HP

139.18860 - 1/2 HP

For Residential Use Only

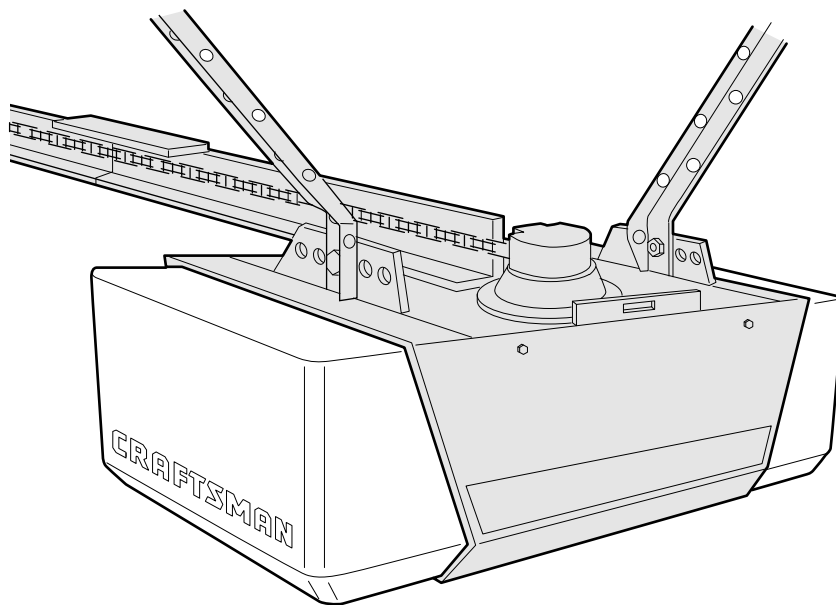

Owner's Manual

- Please read this manual and the enclosed safety materials carefully!
- Fasten the manual near the garage door after installation.
- The door **WILL NOT CLOSE** unless the Safety Reversing System is connected and properly aligned.
- Periodic checks and adjustment of the opener are required to ensure safe operation.
- The model number label is located under the light lens on the left side of your opener.

Contents	Page	Contents	Page
A review of safety alert symbols.....	2	Install the lights and lenses	19
You'll need tools.....	3	Attach emergency release rope and handle.....	19
Safety information regarding garage door locks and ropes.....	3	Electrical requirements	20
Testing your garage door for sticking, binding and balance.....	3	Safety reversing sensor information	21
Illustration of sectional door installation.....	4	Install the safety reversing sensor.....	22, 23
Illustration of one-piece door installation	5	Fasten door bracket (sectional door)	24
Carton inventory.....	6	Fasten door bracket (one-piece door).....	25
Hardware inventory.....	7	Connect door arm to trolley (sectional door).....	26
Assembly section - pages 8 – 11		Connect door arm to trolley (one-piece door)	27
Assemble T-rail	8	Adjustment section - pages 28 – 30	
Attach cable pulley bracket.....	8	Travel limit adjustments.....	28
Install trolley	9	Force adjustments	29
Fasten T-rail to opener	9	Test the safety reversing sensor	30
Install chain/cable	10	Test the safety reverse system	30
Attach sprocket cover	10	Operation safety instructions.....	31
Tighten the chain and cable	11	Care of your opener.....	31
Installation section - pages 11 – 27		Maintenance schedule	31
Installation safety instructions.....	11	Operation of your opener	32
Determine header bracket location		Receiver & transmitter programming	33
Sectional door	12	Having a problem?	34, 35
One-piece door	13	Repair parts, rail assembly.....	36
Install the header bracket	14	Repair parts, installation	36
Attach the T-rail to header bracket.....	15	Repair parts, opener assembly	37
Position the opener.....	16	Accessories.....	38
Hang the opener	17	Index	39
Install the deluxe wall control	18	How to order repair parts.....	40
		Maintenance agreement.....	40
		Warranty	40

Start by reviewing these important safety alert symbols

When you see these Safety Symbols on the following pages, they will alert you to the possibility of *serious injury or death* if you do not comply with the corresponding instructions. The hazard may come from something mechanical or from electric shock. *Read the instructions carefully.*



Mechanical



Electrical

When you see this Safety Symbol on the following pages, it will alert you to the possibility of damage to your garage door and/or the garage door opener if you do not comply with the corresponding instructions. *Read the instructions carefully.*



This garage door opener is designed and tested to offer safe service provided it is installed, operated, maintained and tested in strict accordance with the safety instructions contained in this manual.

You'll Need Tools

During assembly, installation and adjustment of the opener, instructions will call for hand tools shown below.

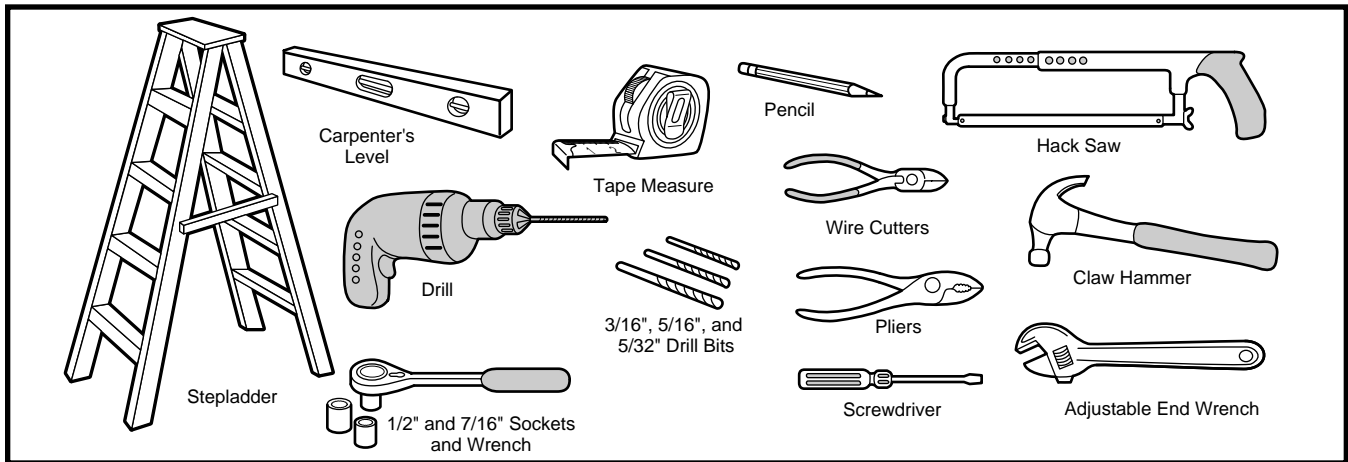

WARNING

An unbalanced garage door might not reverse when required and someone under the door could be seriously injured or killed.

If your garage door binds, sticks or is out of balance, call for professional garage door service. Garage doors, door springs, cables, pulleys, brackets and their hardware, are under extreme tension and can cause serious injury or death. Do not try to loosen, move or adjust them yourself!

Ropes left on a garage door could cause someone to become entangled and killed. Remove all ropes connected to the door before installing and operating the opener.



CAUTION

To avoid damage to the garage door and opener, disable locks before installing and operating the opener. Use a wood screw or nail to hold locks in the "open" (unlocked) position. Operation at other than 120V 60 Hz will cause opener malfunction and damage.

Before you begin, complete the following test to make sure your door is balanced, and is not sticking or binding:

- Lift the door about halfway as shown. Release the door. It should stay in place, supported entirely by its springs.
- Raise and lower the door to see if there is any binding or sticking.

Identify the type and height of your door and any special conditions that exist and any additional materials that may be required by referring to the lists on pages 4 or 5.

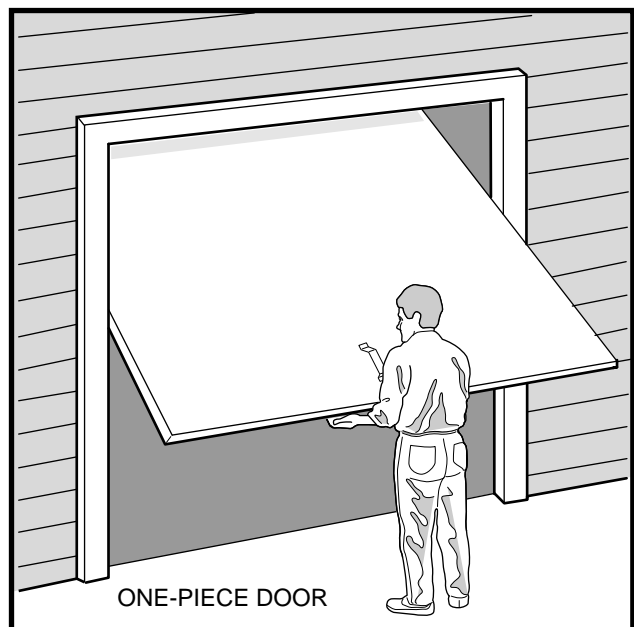

SECTIONAL Door Installation

Before you begin, survey your garage area to see whether any of the conditions below apply to your installation.

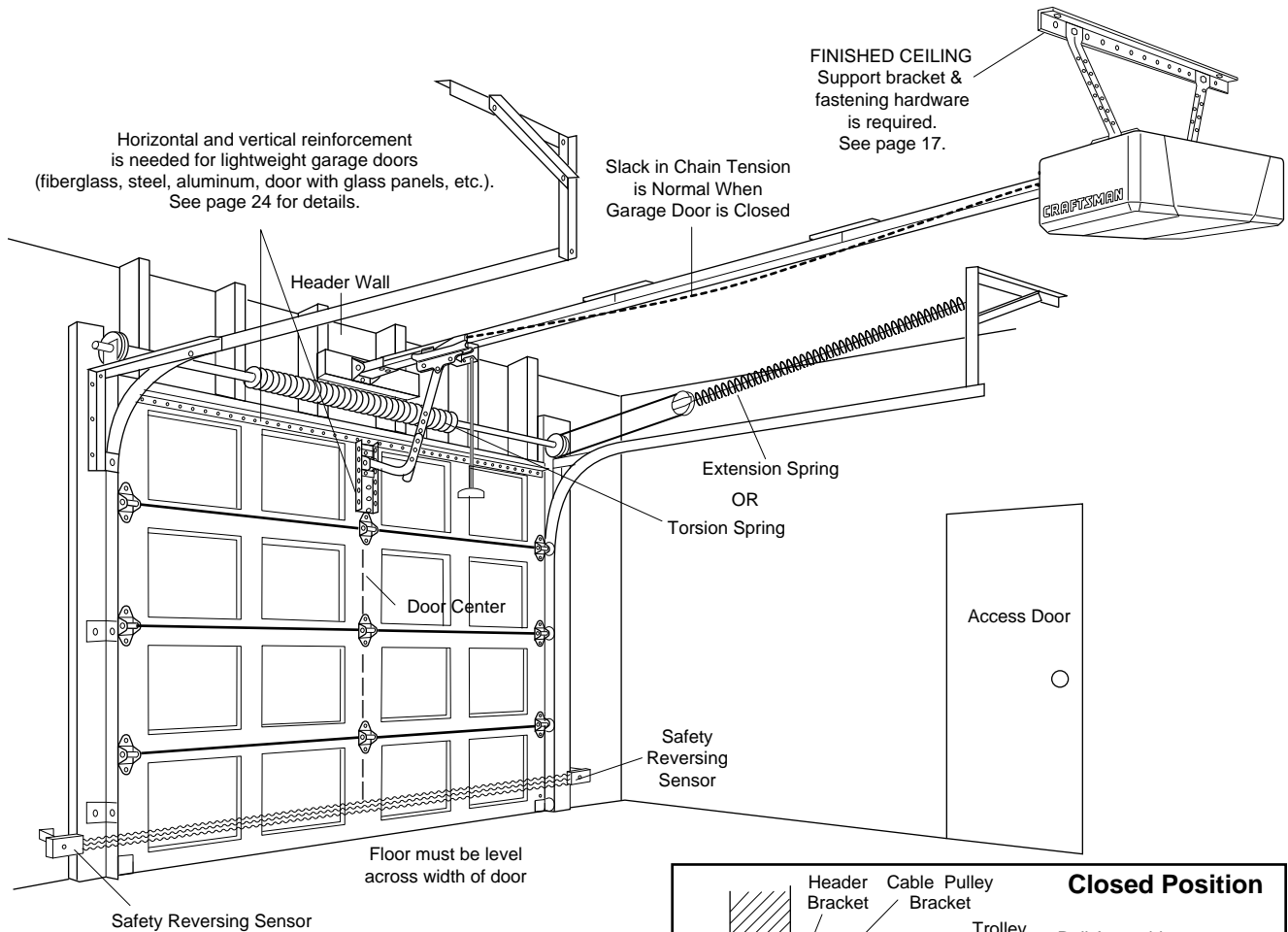

Based on your particular requirements, there are several installation steps which might call for materials and/or hardware not included in the carton.

- Step 1, page 12 - Look at the wall or ceiling above the garage door. The header bracket *must* be securely fastened to structural supports.
- Step 5, page 17 - Do you have a finished ceiling in your garage? If so, a support bracket and additional fastening hardware may be required.
- Safety reversing sensor, page 21 - Depending upon garage construction, wood blocks may need to be fastened to mounting locations before sensors are installed.
- Step 10, page 22 - Alternate floor mounting of the safety reversing sensor will require hardware not provided.
- Step 11, page 24 - Do you have a steel, aluminum, fiberglass or glass panel door? If so, horizontal and vertical reinforcement is required.
- Look at the garage door where it meets the floor. It must close on the floor all the way across. Otherwise, the safety reverse system may not work properly. See page 30. Floor or door should be repaired.

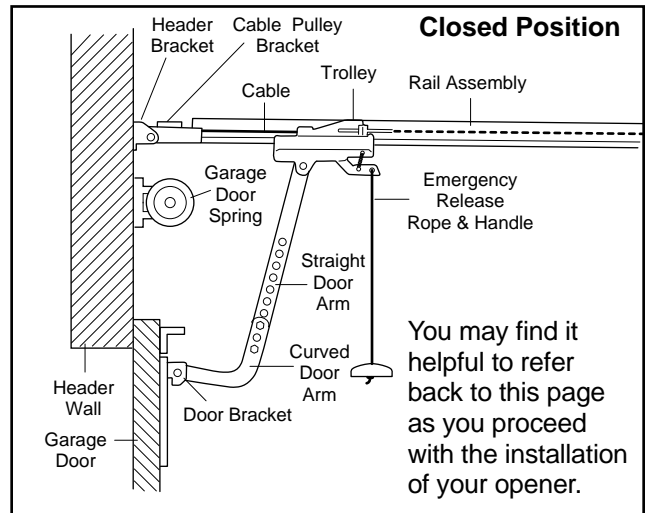

- An 8 foot high door will require Item No. 18754 Rail Extension Kit. A 10 foot high door will require Item No. 18753 Rail Extension Kit.
- The opener can be installed within 2 feet to the left or right of the door center if there is a torsion spring or center bearing plate in the way of the header bracket or door bracket area. If your door has extension springs, the opener *must* be installed in the center of the door. See pages 12 and 24.
- Do you have an access door in addition to the garage door? If not, Model 18752 Outside Trolley Release is required. See page 38.

ONE-PIECE Door Installation

Before you begin, survey your garage area to see whether any of the conditions below apply to your installation.

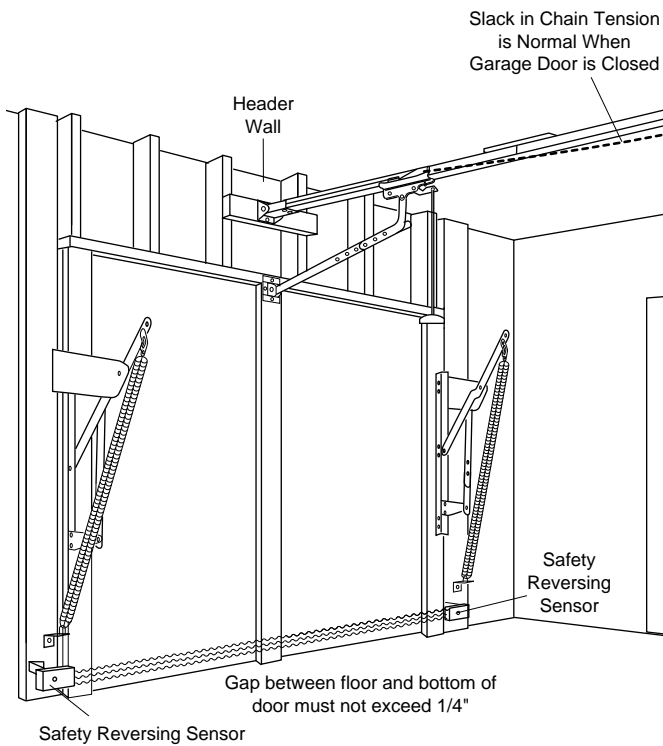

One-Piece Door without Track

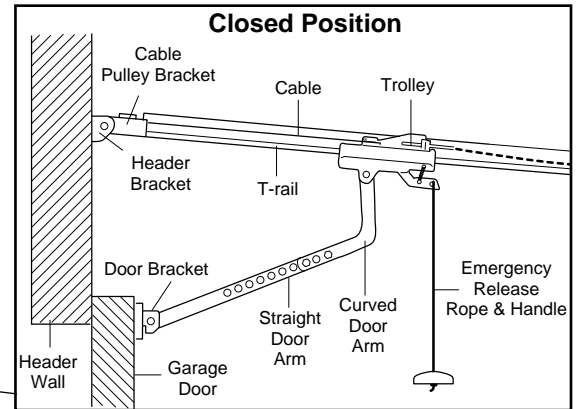
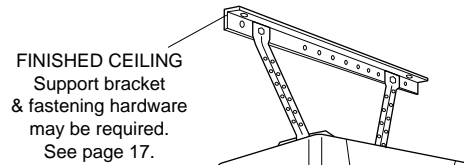

Based on your particular requirements, there are several installation steps which might call for materials and/or hardware not included in the carton. You may want to review these steps before beginning:

- Step 1, page 13 - Look at the wall or ceiling above the garage door. The header bracket *must* be securely fastened to structural supports.
- Step 5, page 17 - Do you have a finished ceiling in your garage? If so, a support bracket and additional fastening hardware (not supplied) may be required.
- Safety reversing sensor, page 21 - Depending on garage construction, wood blocks may need to be securely fastened to mounting locations before sensors are installed.
- Step 10, page 22 - Alternate floor mounting of the safety reversing sensor will require hardware that is not provided.
- Step 11, page 25 - Generally, a one-piece door does not require reinforcement. If your door is lightweight, you can refer to the information relating to sectional doors on page 24.
- Step 11, page 25 - Depending on your door's construction, you might need additional mounting hardware for the door bracket.
- Do you have an access door in addition to the garage door? If not, Model 18752 Outside Trolley Release is required. See page 38.
- The gap between the bottom of the garage door and the floor cannot exceed 1/4". Otherwise, the safety reverse system may not work properly. See page 30. The floor or the door should be repaired.

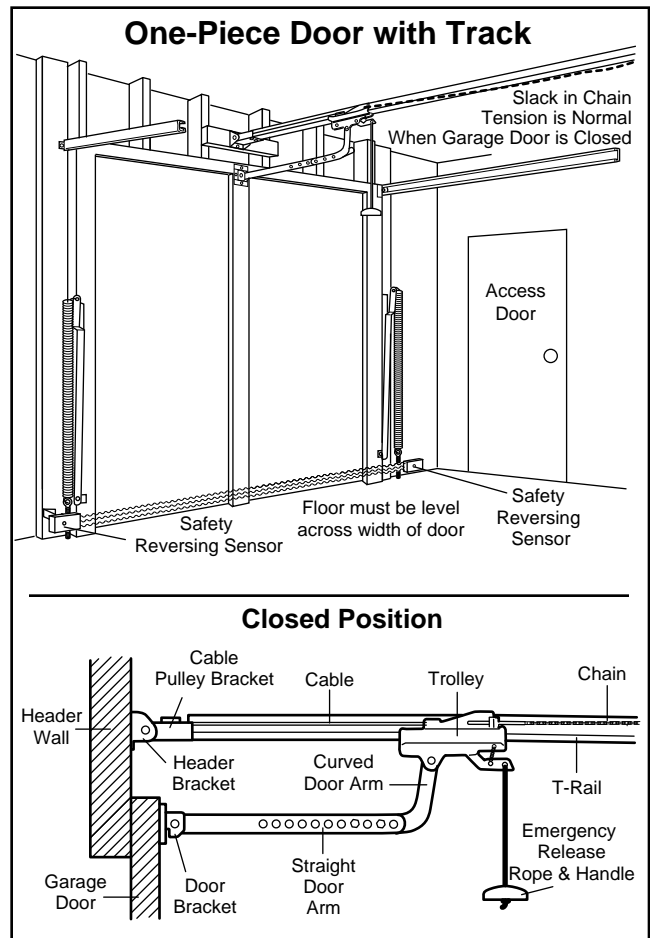

You may find it helpful to refer back to this page as you proceed with the installation of your opener.



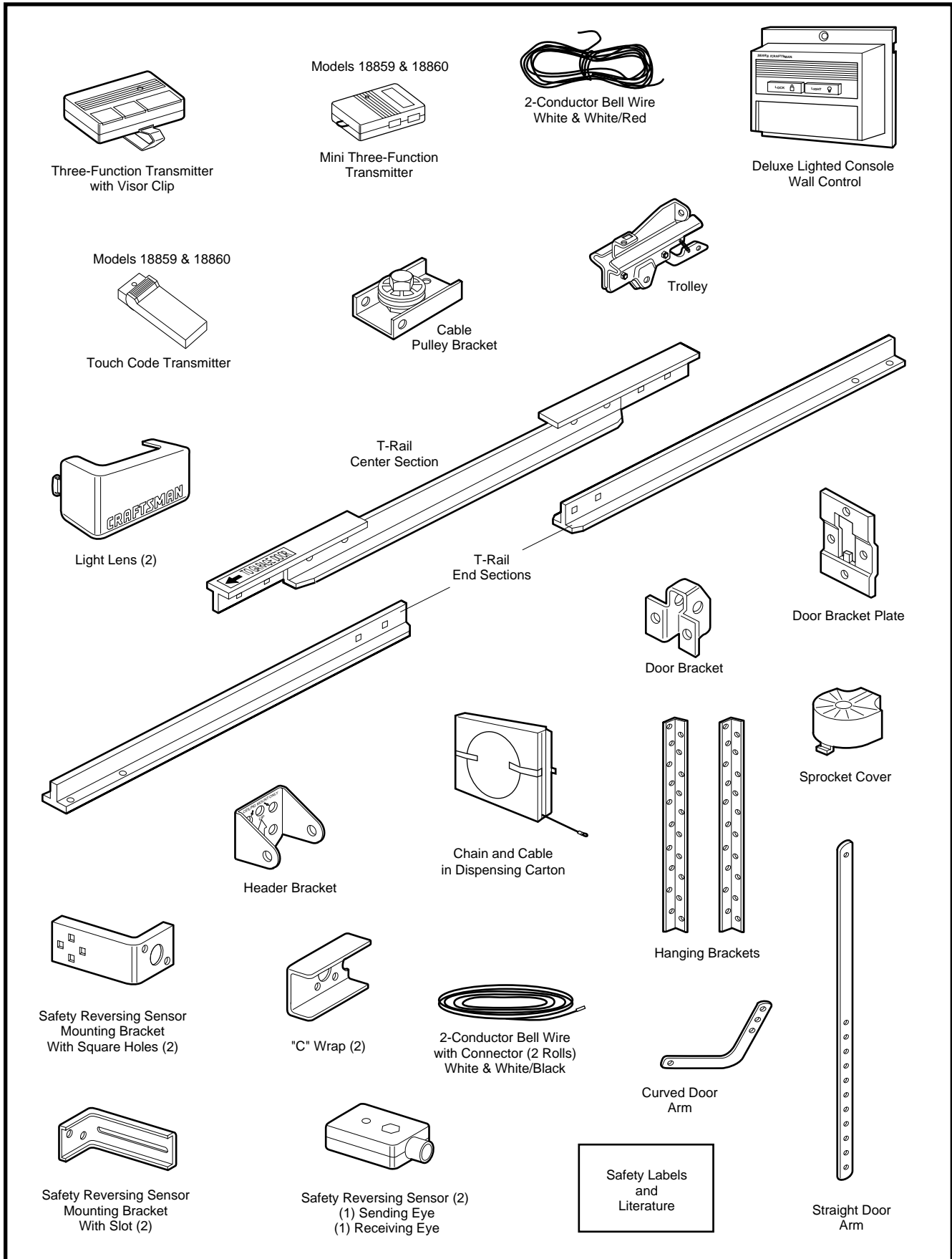

Opener Carton Inventory

Your garage door opener is packaged in two cartons which contain all parts illustrated below. If anything is missing, carefully check the packing material. Parts may be "stuck" in the foam. Hardware for assembly and installation is shown on page 7.



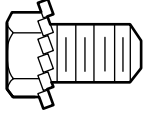
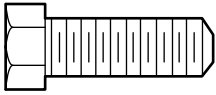

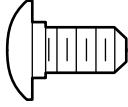
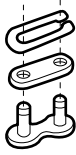
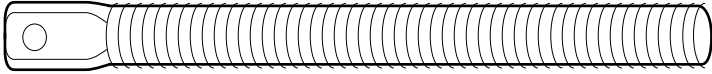

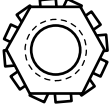

Group all hardware found in all packages contained in the rail and opener cartons into the three kits illustrated below.

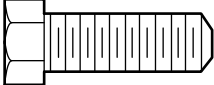

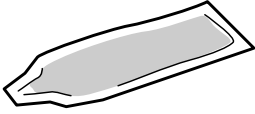

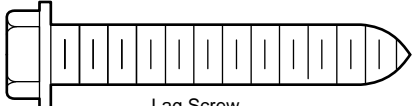

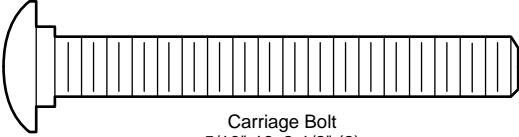
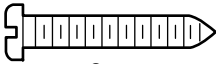
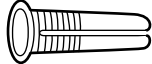
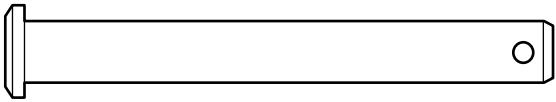
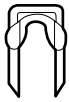
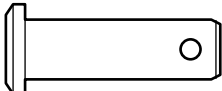
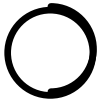
Rail Assembly Hardware Kit 41A3534

 Washed Screw 5/16"-18x1/2" (2) (mounted in opener)	 Hex Screw 5/16"-18x7/8" (3)	 Nut 5/16"-18 (5)	 Carriage Bolts 1/4"-20x1/2" (4)	 Master Link (2)
 Trolley Threaded Shaft (1)		 Lock Washer 5/16" (4)	 Lock Nut 1/4"-20 (4)	

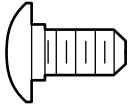
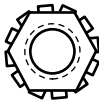
Installation Hardware Kit 41A3535

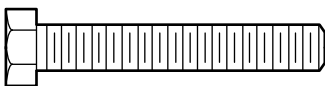
 Hex Screw 5/16"-18x7/8" (4)	 Handle	 Rail Grease	 Rope
 Lag Screw 5/16"-18x1-7/8" (4)	 Nut 5/16"-18 (6)	 Lock Washer 5/16" (6)	
 Carriage Bolt 5/16"-18x2-1/2" (2)	 Screw 6ABx1" (2)	 Dry Wall Anchors (2)	
 Clevis Pin 5/16"x2-3/4" (1)	 Insulated Staples (10)	 Clevis Pin 5/16"x1" (2)	 Ring Fastener (3)

Safety Reversing Sensor Installation Hardware Kit 41A4116

 Lag Screw 1/4x1-1/2" (4)	 Carriage Bolts 1/4"-20x1/2" (4)	 Lock Nut 1/4"-20 (4)	 Wing Nut (2)
 Hex Screw 1/4-20x1-1/2" (2)	 Screw #10-32x3/8" (4)	 Lock Nut #10x32 (4)	 Insulated Staples (20)

Assembly Section: Pages 8 – 11

To avoid installation difficulties, do not run the garage door opener until instructed to do so.

Assembly Step 1

Assemble the T-rail & Attach the Cable Pulley Bracket

- Align the 3 T-rail sections on a flat surface exactly as shown. The end sections are identical. Make sure the "arrow label" on the center section is pointing toward the door.
- Insert the carriage bolts so the square bolt necks seat in the square holes in the T-rail end sections and pass through the round holes in T-rail center section. Assemble lock nuts, ensure alignment and tighten.

Make sure bolt necks are seated in the square holes and rails are aligned before you tighten lock nuts. (See right and wrong views). Improper assembly can cause jerky trolley operation, noise and/or nuisance door reversals.

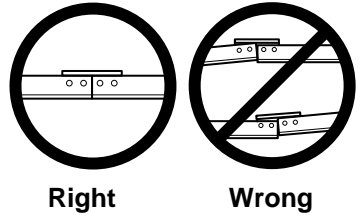

If T-rail is not assembled EXACTLY as shown, trolley will not travel smoothly along length of rail or it will hit against the nuts.

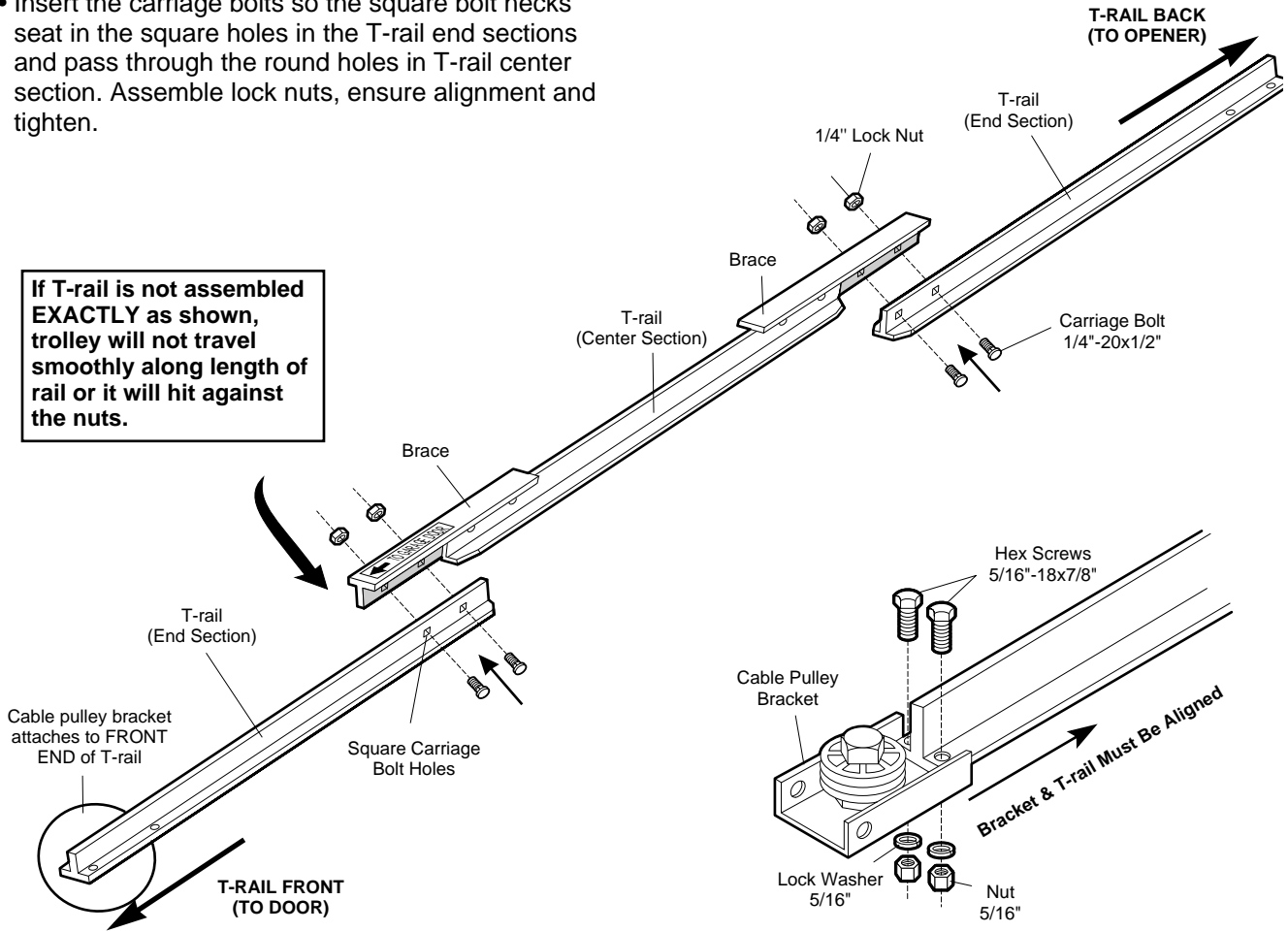

Hardware Shown Actual Size

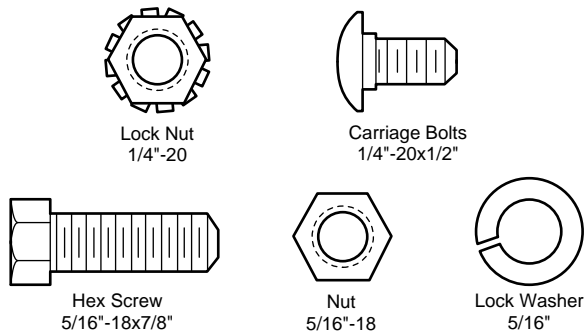

- Position the cable pulley bracket on the front end of the T-rail as shown. Fasten securely with the hardware.

When tightening the screws, be sure to keep bracket parallel to the rail. Otherwise, the rail may bow when opener is operated.

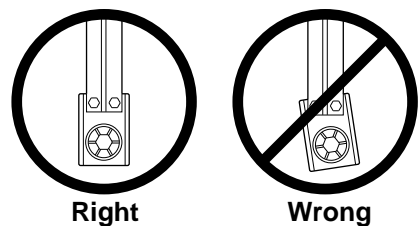

Assembly Step 2

Install the Trolley on the T-rail

- Attach the threaded shaft to the trolley with the lock washer and nuts as shown.

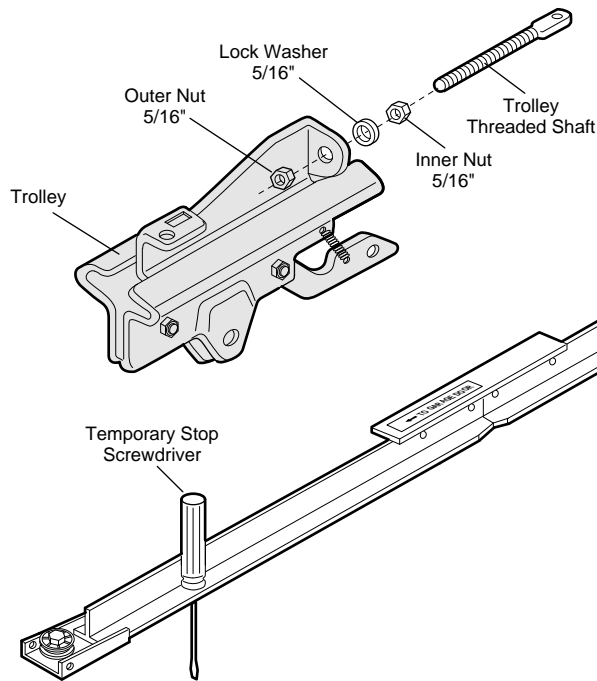

Hardware Shown Actual Size

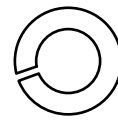

Lock Washer
5/16"

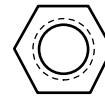

Nut
5/16" -18

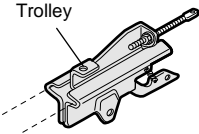

- As a temporary stop, insert a screwdriver into the hole in the front end of the T-rail.
- Slide the trolley assembly along the rail to the screwdriver stop.

If trolley hits against the nut on the T-rail, the bolts and nuts were attached from the wrong side and must be repositioned. Review Step 1.

Assembly Step 3

Fasten the T-rail to the Opener

- Place the opener on packing material to protect the cover. For convenience, put a support under the cable pulley bracket.
- Remove the (2) 5/16"-18x1/2" washered screws mounted in the top of the opener.
- Align the holes in the back section of the T-rail with the holes in the opener.
- Fasten the rail with the (2) washered screws previously removed. Tighten securely.

Remember to use only these screws! Any other screws will cause serious damage to the opener.

- Insert a 5/16"-18x7/8" hex screw into the trolley stop hole in the T-rail as shown. Tighten securely with a 5/16" lock washer and nut. This screw limits trolley travel in the UP direction.

Hardware Shown Actual Size

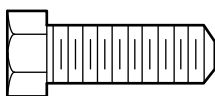

Hex Screw
5/16"-18x7/8"



Nut
5/16"-18

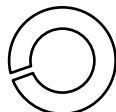

Lock Washer
5/16"



CAUTION

To fasten rail, use only those screws mounted in the top of the opener. Any other screws will cause serious damage to the opener.

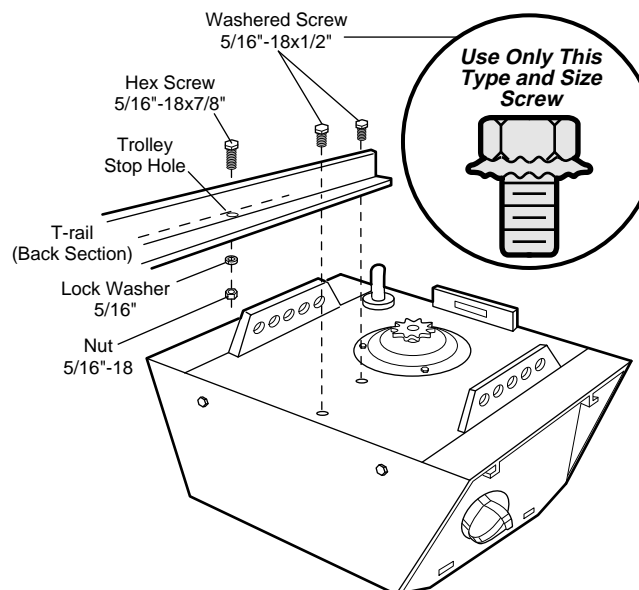

Assembly Step 4

Install the Chain/Cable & Attach the Sprocket Cover

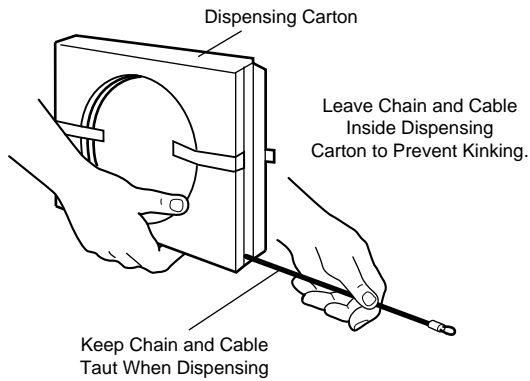

- Detach the cable loop from the carton and fasten it to the trolley with a master link from the hardware bag. See master link procedure, Figure 1.
- With the trolley against the screwdriver, dispense the cable around the pulley.
- Proceed back around the opener sprocket, Figure 2. Be sure sprocket teeth engage the chain. Continue forward to the trolley threaded shaft, Figure 3.
- Use the second master link to connect the chain to the flat end of the shaft. **Check to make sure the chain is not twisted.**
- Remove the screwdriver.

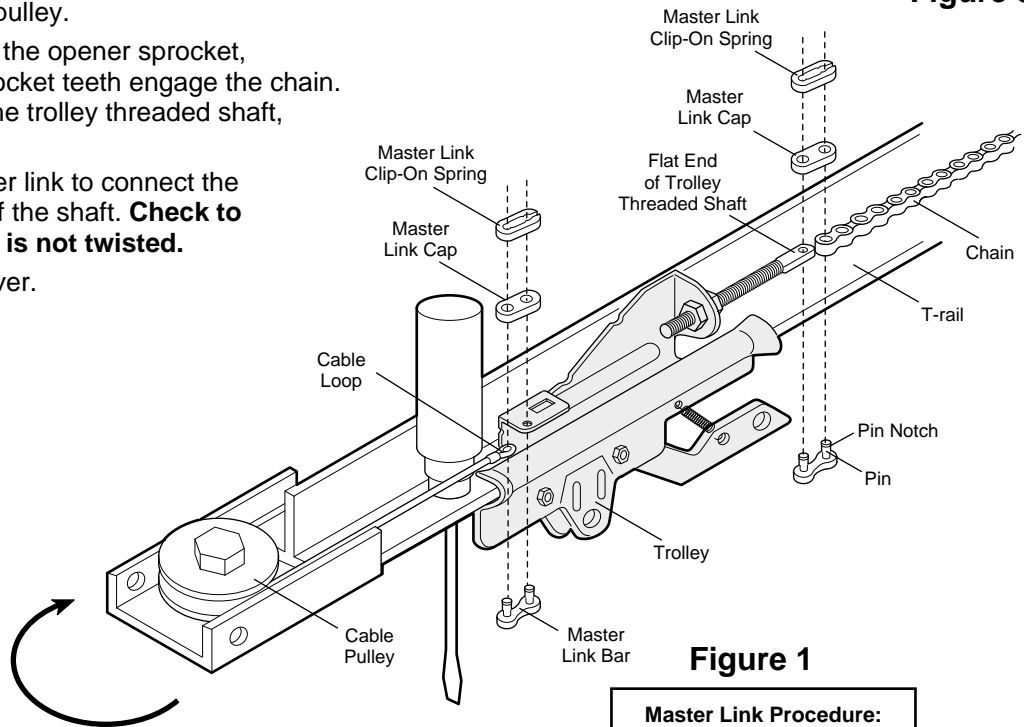
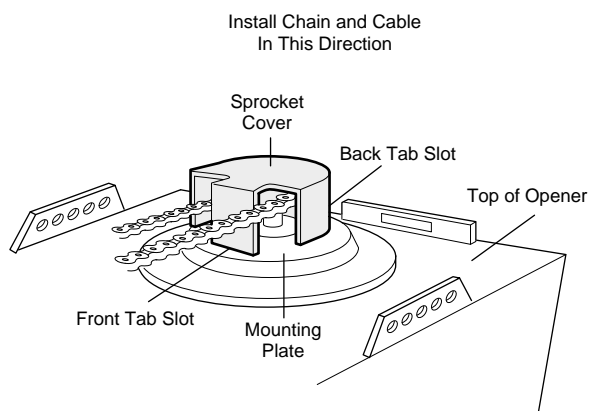

Figure 1

Master Link Procedure:

Push pins of master link bar through cable loop and hole in front end of trolley. Push cap over pins and into notches. Slide clip-on spring over cap and into notches until both pins are securely locked.



WARNING

Serious injury can result if fingers become entangled in moving opener sprocket. Attach sprocket cover securely. Never operate opener while your hand is near the opener sprocket.

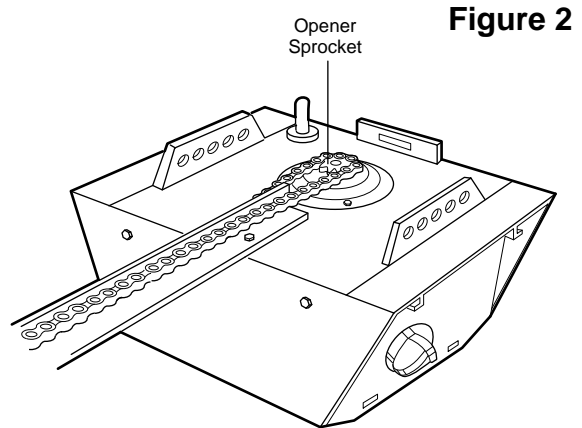

Figure 2

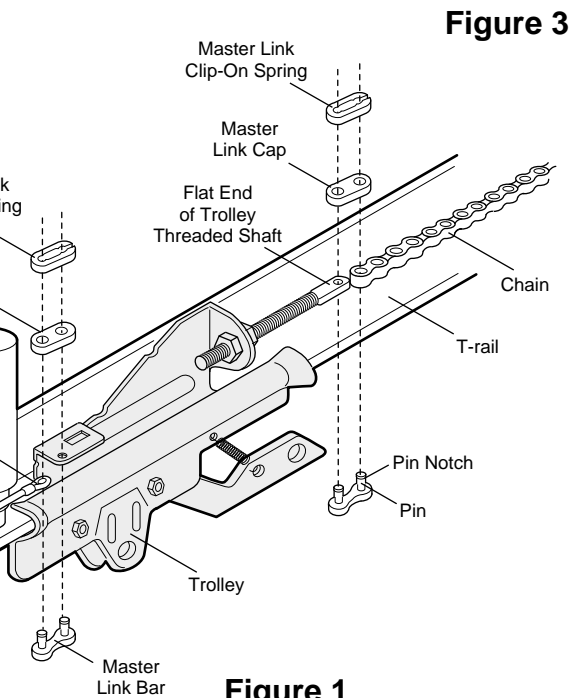

Figure 3

To attach the sprocket cover:

- Insert the back tab in the opener slot. Squeeze the cover slightly and insert the front tab in the slot on the mounting plate.

Assembly Step 5

Tighten the Chain & Cable

- Spin the inner nut and lock washer down the threaded trolley shaft, away from the trolley.
- To tighten the chain, turn outer nut in the direction shown. **As you turn the nut, keep the chain from twisting.**
- When the chain is approximately 1/2" above the base of the T-rail at its midpoint, re-tighten the inner nut to secure the adjustment.

Sprocket noise can result if chain is either too loose or too tight.

When installation is complete, you may notice some chain droop with the door closed. This is normal. If the chain returns to the position shown when the door is open, *do not re-adjust the chain.*

NOTE: During future maintenance, ALWAYS pull the emergency release handle to disconnect trolley before adjusting chain.

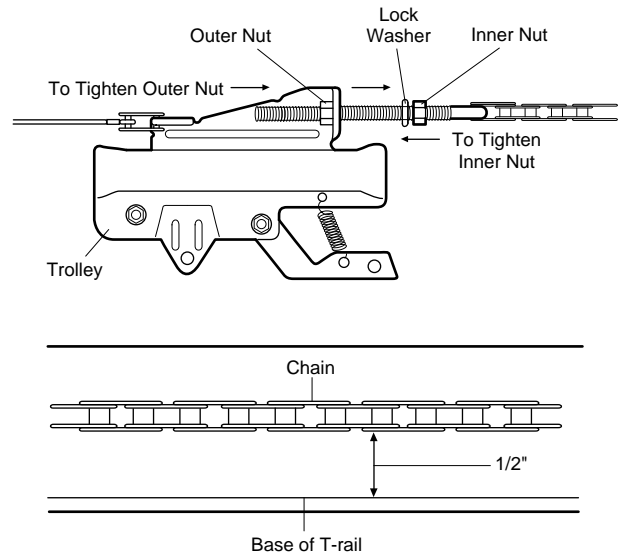

You have now finished assembling your garage door opener. Please read the following warnings before proceeding to the installation section:

IMPORTANT INSTALLATION INSTRUCTIONS



WARNING



WARNING

To reduce the risk of severe injury or death to persons:

1. **READ AND FOLLOW ALL INSTALLATION INSTRUCTIONS**
2. Install only on a properly balanced and lubricated garage door. *An improperly balanced door could result in severe injury or death.* Repairs to cables, spring assemblies and other hardware must be made by a professional service person before installing opener.
3. Disable all locks and remove all ropes connected to the garage door before installing the opener. *Ropes connected to a garage door can cause entanglement and death.*
4. If possible, install door opener 7 feet or more above floor with the manual release handle mounted 6 feet above the floor.
5. Do not connect the opener to power source until instructed to do so.
6. Locate the Wall Control within sight of the door at a minimum height of 5 feet where small children cannot reach and away from all moving parts of the door.
7. Install the User Safety Instruction Label on the wall adjacent to the control button and the Maintenance Instruction Label in a prominent location on the inside of the garage door.
8. Upon completion of the installation, the door must reverse when it comes in contact with a 2x4 laid flat on the floor.
9. Do not wear watches, rings or loose clothing while installing or servicing an opener. Jewelry or loose clothing can be caught in the mechanism of the garage door or the opener.

Installation Step 1

Determine Header Bracket Location

Installation procedures vary according to garage door types. Follow the instructions which apply to your door



WARNING

If the header bracket is not rigidly fastened to a structural support on the header wall or ceiling, the safety reverse system may not work properly (see page 30). *The door might not reverse when required, and could cause serious injury or death.*

The garage door springs, cables, pulleys, brackets and their hardware are under extreme tension. *Do not attempt to loosen, move or adjust them yourself. Serious personal injury or death could result. Call for garage door service.*

SECTIONAL Door and ONE-PIECE Door With Track

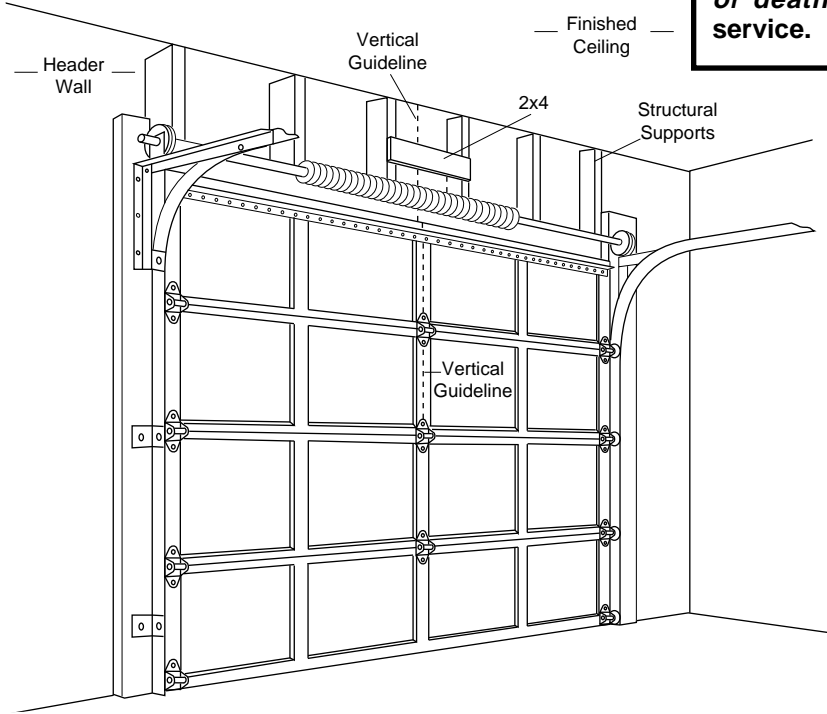

- Close the door and mark the inside vertical centerline of the garage door.
- Extend the line onto the header wall above the door.

Remember, you can fasten the header bracket within 2 feet to the left or right of the door center *only* if a torsion spring or center bearing plate is in the way; or you can attach it to the ceiling (refer to page 14) when clearance is minimal.

If you need to install the header bracket on a 2x4 (on wall or ceiling), use lag screws (not supplied) to securely fasten the 2x4 to structural supports.

- Open your door to the highest point of travel as shown. Draw an intersecting horizontal line on the header wall 2" above the high point. This height will provide travel clearance for the top edge of the door.

Door clearance brackets are available for sectional doors when headroom clearance is less than 2". See accessory page 38.

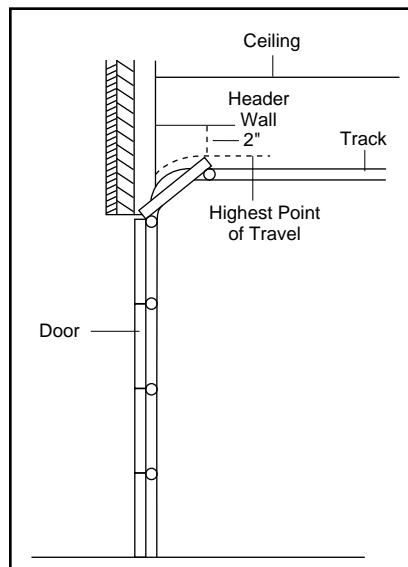

Sectional door with curved track

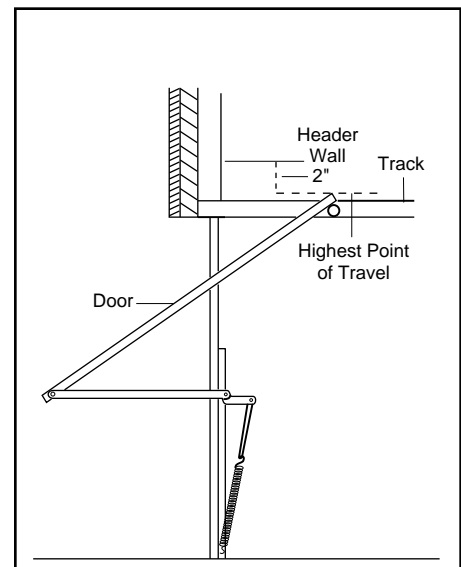

One-piece door with horizontal track

Proceed to Step 2, page 14.

ONE-PIECE Door Without Track

Read the Safety Instructions on page 12. They also apply to doors without tracks.

- Close the door and mark the inside vertical centerline of your garage door. Extend the line onto the header wall above door.

If headroom clearance is minimal, you can install the header bracket on the ceiling. See page 14.

- If you need to install the header bracket on a 2x4 (on wall or ceiling), use lag screws (not supplied) to securely fasten the 2x4 to structural supports as shown.

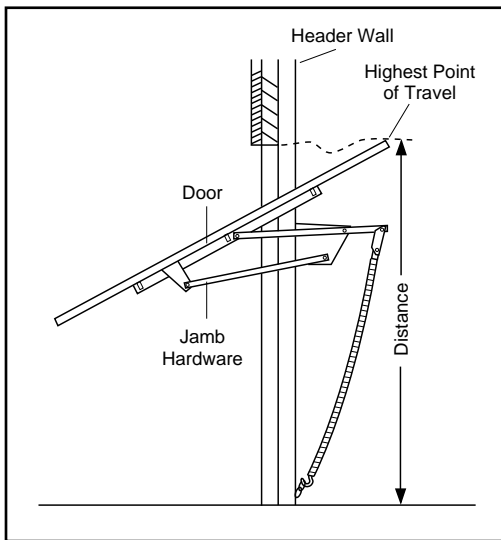
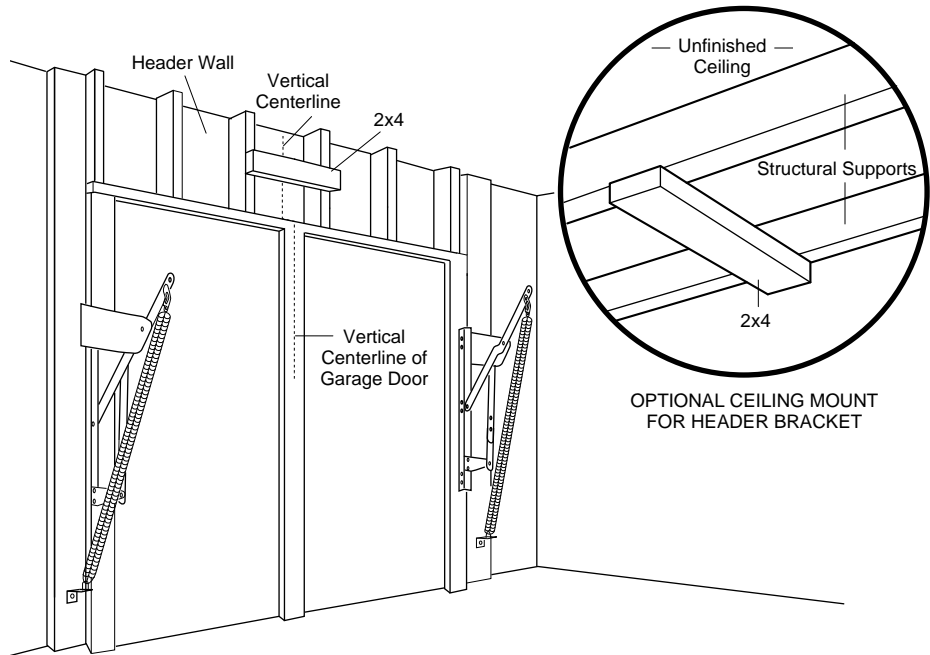

One-piece door without track jamb hardware

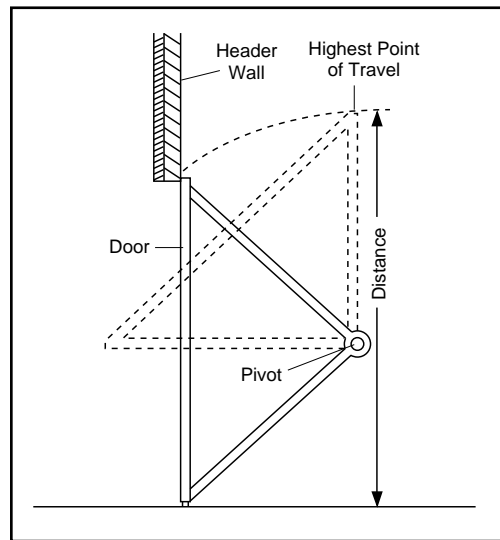

One-piece door without track pivot hardware

- Open your door to the highest point of travel as shown. Measure the distance from the top of the door to the floor. Subtract the actual height of the door. Add 8" to the remainder. (See Example).
- Close the door and draw an intersecting horizontal line on the header wall at the determined height.

If the total number of inches exceeds the height available in your garage, use the maximum height possible, or refer to page 14 for ceiling installation.

EXAMPLE

Distance from top of door (at highest point of travel) to floor.....	92"
Actual height of door	-88"
Remainder	4"
Add	+8"
Bracket height on header wall	=12"

(Measure UP from top of CLOSED door.)

Proceed to Step 2, page 14.

Installation Step 2

Install the Header Bracket

You can attach the header bracket either to the wall above the garage door, or to the ceiling. Follow the instructions which will work best for your particular requirements.

Fasten the Header Bracket to the Wall

- Center the bracket on the vertical guideline with the bottom edge of the bracket on the horizontal line as shown (with the arrow pointing toward the ceiling).

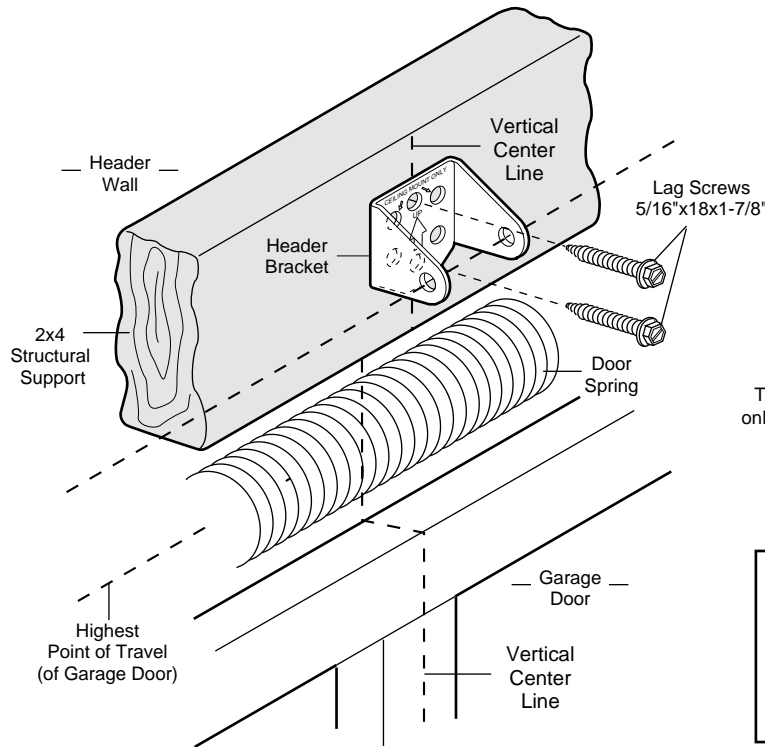

- Mark either set of bracket holes (do not use the holes designated for ceiling mount). Drill 3/16" pilot holes and fasten the bracket securely to structural support with the hardware provided.

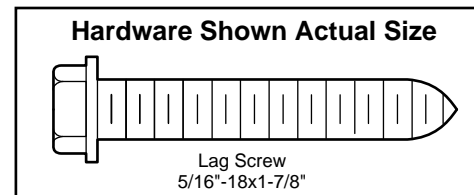
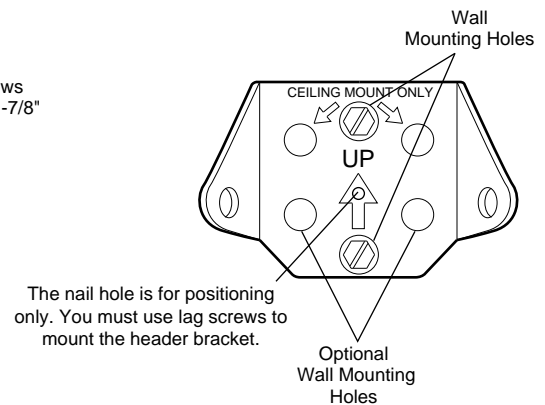

Fasten the Header Bracket to the Ceiling

- Extend the vertical guideline onto the ceiling as shown.
- Center the bracket on the vertical mark, no more than 6" from the wall. Make sure the arrow is pointing toward the wall. The bracket can be mounted flush against the ceiling when clearance is minimal.
- Mark holes designated for ceiling mount only. Drill 3/16" pilot holes and fasten bracket securely to structural support with the hardware provided.

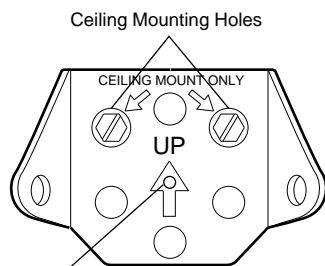

The nail hole is for positioning only. You must use lag screws to mount the header bracket.

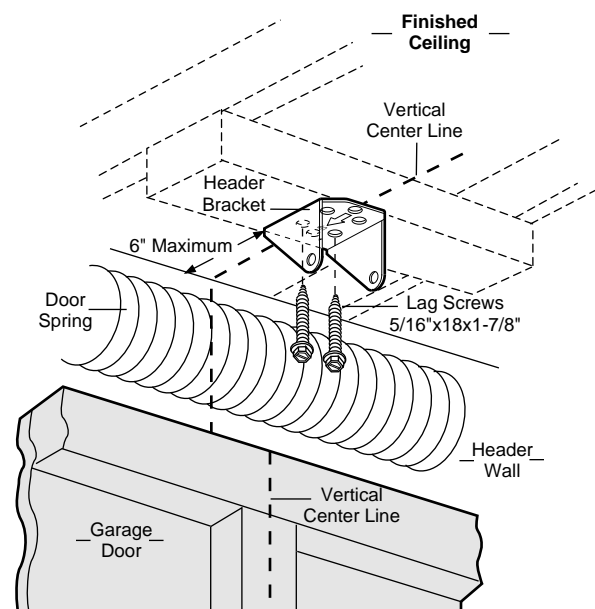

Installation Step 3

Attach the T-rail to the Header Bracket

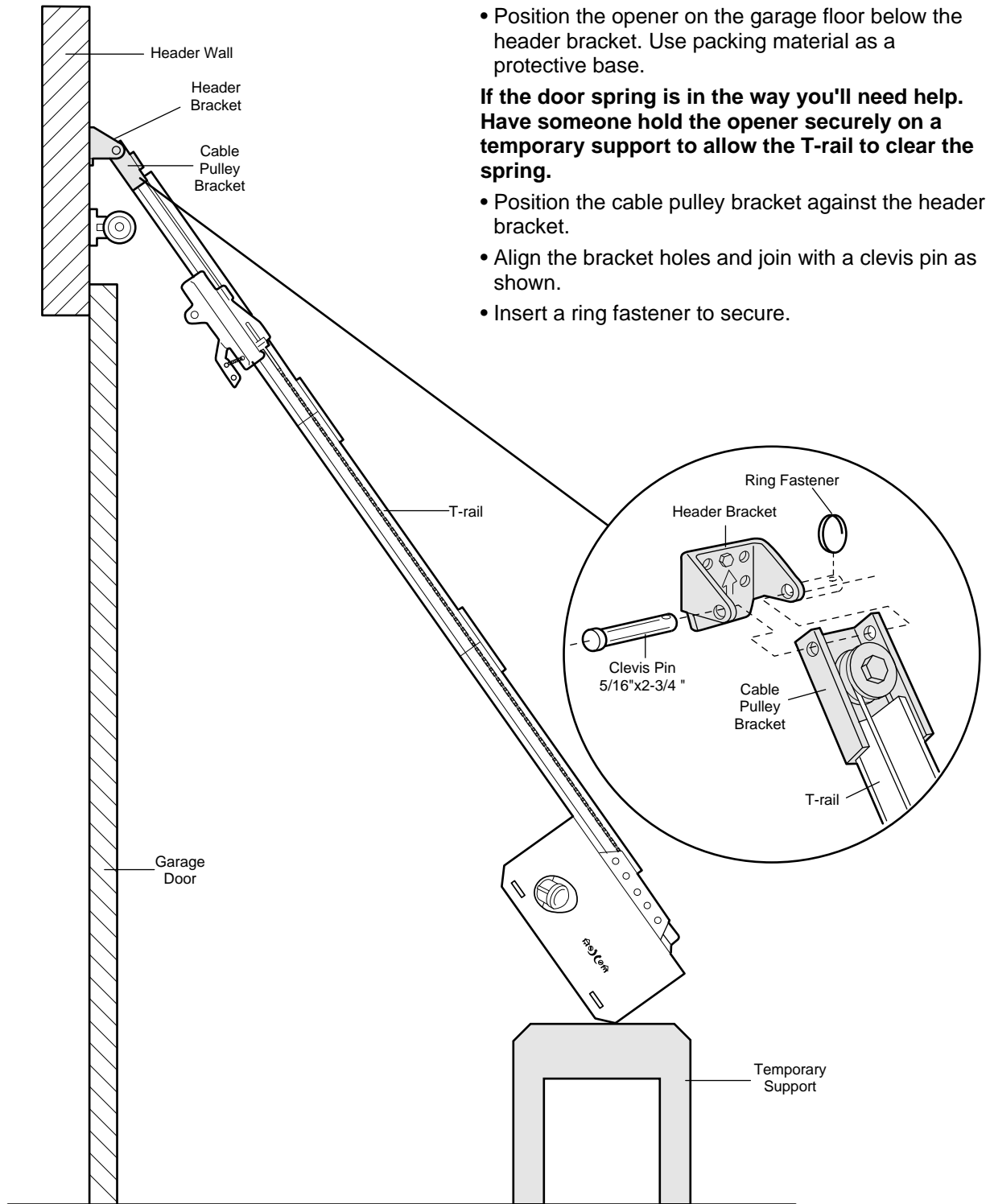

- Position the opener on the garage floor below the header bracket. Use packing material as a protective base.

If the door spring is in the way you'll need help. Have someone hold the opener securely on a temporary support to allow the T-rail to clear the spring.

- Position the cable pulley bracket against the header bracket.
- Align the bracket holes and join with a clevis pin as shown.
- Insert a ring fastener to secure.

Hardware Shown Actual Size

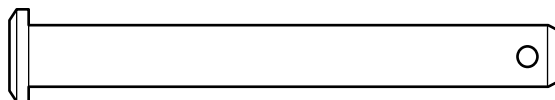

Clevis Pin
5/16"x2-3/4"

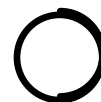

Ring Fastener

Installation Step 4

Position the Opener

Follow instructions which apply to your door type as illustrated.



CAUTION

To prevent damage to steel, aluminum, fiberglass or glass panel doors, do not rest the opener on the door without using a 2x4.

SECTIONAL Door & ONE-PIECE Door with Track

A 2x4 laid flat is convenient for setting an ideal door-to-T-rail distance.

- Raise the opener onto a stepladder.

You will need help at this point if the ladder is not tall enough.

- Open the door all the way and place a 2x4 laid flat on the top section beneath the T-rail.

If the top panel hits the trolley when you raise the door, pull down on the trolley release arm to disconnect the inner and outer sections. The trolley can remain disconnected until Step 12 is completed.

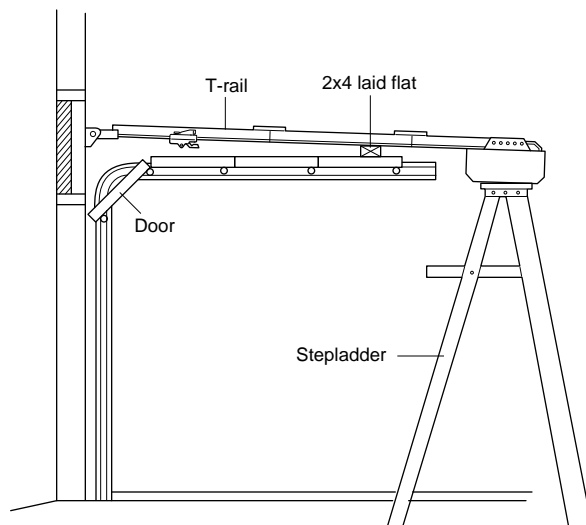
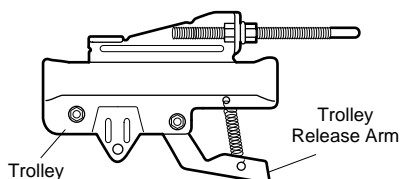

ONE-PIECE Door without Track

- With the door fully open and parallel to the floor, measure the distance from the floor to the top of the door.
- Using a stepladder as a support, raise the opener to the same distance as the door from the floor (it will be at a slight angle as shown).
- The top of the door should be level with the top of the opener. Do not position the opener more than 2" above this point.

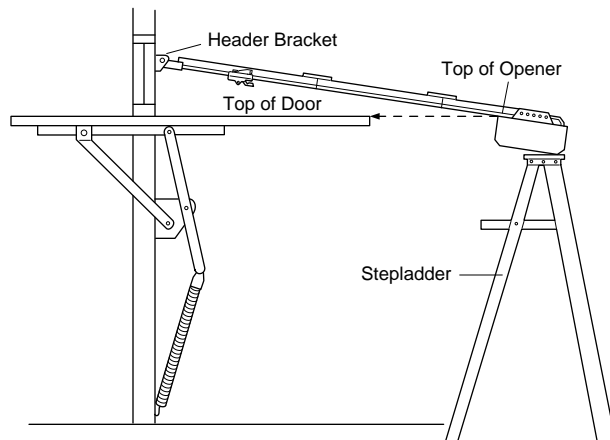

Installation Step 5

Hang the Opener

Two representative installations are shown. Yours may be different. Hanging brackets should be angled, Figure 1, to provide rigid support. On finished ceilings, Figure 2, attach a sturdy metal bracket to structural supports before installing the opener. The bracket and fastening hardware are not supplied.

- Measure the distance from *each* side of the opener to the structural support.
- Cut both pieces of the hanging bracket to required lengths.
- Drill $3/16$ " pilot holes in the structural supports.
- Attach one end of each bracket to a support with $5/16$ "x $1-7/8$ " lag screws.
- Fasten the opener to the hanging brackets with $5/16$ "- 18 x $7/8$ " screws, lock washers and nuts.
- Check to make sure the T-rail is centered over the door (or in line with the header bracket if the bracket is not centered above the door).
- Remove the 2x4. Operate the door manually. If the door hits the rail, raise the header bracket.

Grease the top and underside of the rail surface where the trolley slides with rail grease.

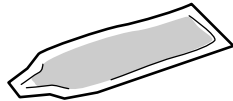

Hardware Shown Actual Size

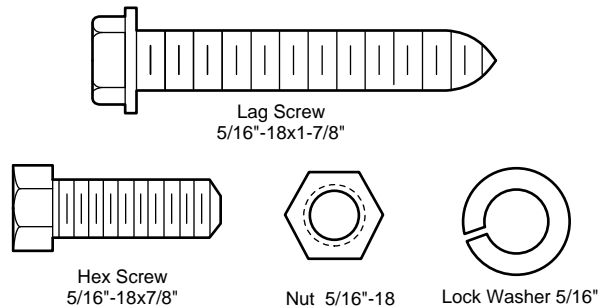

WARNING

The opener could fall and injure someone if it is not properly secured. Fasten the opener securely to structural supports of the garage.

Figure 1

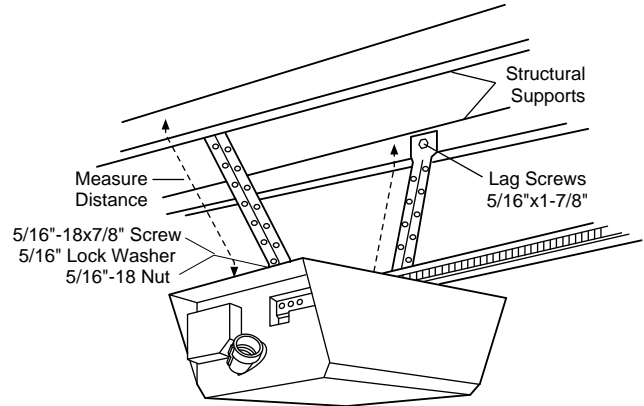
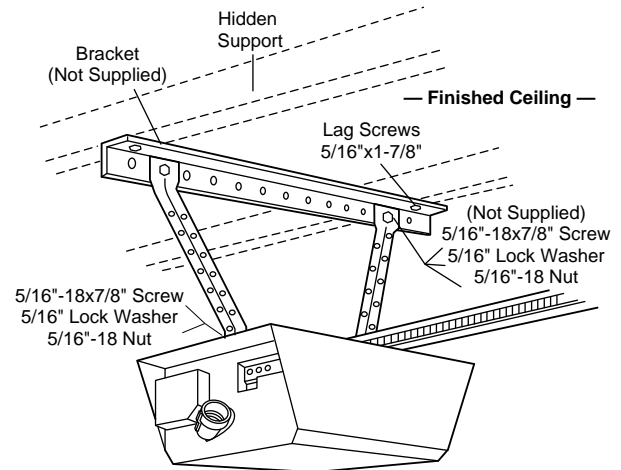

Figure 2



Installation Step 6

Install the Deluxe Lighted Console Wall Control

- Strip 1/4" of insulation from one end of the bell wire; connect the wire to the two screw terminals on the back of the Wall Control: white to 2; white/red to 1.
- Locate the Wall Control within sight of the door at a minimum height of 5 feet where small children cannot reach, and away from all moving parts of the door and door hardware. Fasten the Wall Control securely with 6ABx1" screws. If installing into drywall, drill 5/32" holes and use the anchors provided.
- Run the bell wire up the wall and across the ceiling to the opener. Use insulated staples to secure the wire in several places. Be careful not to pierce the wire with a staple, thereby resulting in a short.
- Receiver terminal screws and the antenna are located on the right side panel of the opener. Position the antenna wire as shown.
- Then connect the bell wire to the opener terminal screws: white to 2; white/red to 1.
- Remember to affix the User Safety Instruction label to the wall near the Wall Control, and the Maintenance Instruction label in a prominent location on the inside of the garage door.

If the label adhesive will not adhere to your garage wall surface (or becomes loose with time) use tacks to secure the label alongside the control button.

Hardware Shown Actual Size

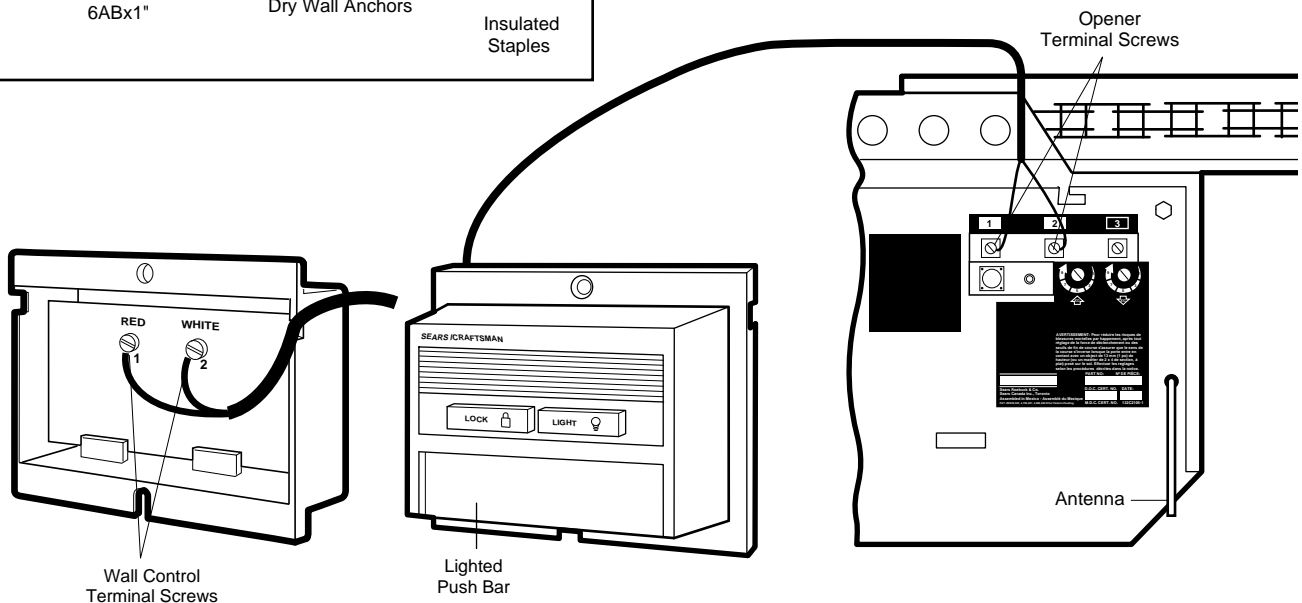
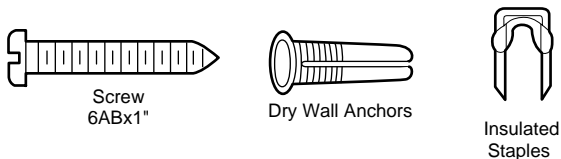

WARNING

Children operating or playing with a garage door opener can injure themselves or others. *The garage door could close and cause serious injury or death.*

Install the Wall Control (or any additional push buttons) out of the reach of children and away from all moving parts of the door and door hardware, *but where the garage door is visible.* Do not allow children to operate the push button(s) or the remote control transmitter(s).

A moving garage door could injure someone under it. Activate the opener only when the door is properly adjusted, you can see it clearly, and there are no obstructions to door travel.

Do NOT connect the power and operate the opener at this time. The trolley will travel to the full open position but will not return to the close position until the sensor beam is connected and properly aligned.

See Safety Reversing Sensor instructions beginning on page 21.

Page 32 explains how to operate the opener using the lighted push bar and the Lock & Light features available on the Deluxe Lighted Console Wall Control.

Outdoor Key Switch Accessory Connections:

To opener terminal screws: white to 2; white/red to 1

Installation Step 7

Install the Lights and the Lenses

Install the lights

- Install a 75 watt maximum light bulb in each socket. The lights will turn ON and remain lit for approximately 4-1/2 minutes when power is connected. Then the lights will turn OFF.
- If the bulbs burn out prematurely due to vibration, replace them with "Garage Door Opener" bulbs.

Install the lenses

- Apply slight pressure on the sides of each lens and slide the tabs into the slots in the side panels.
- **For convenience, the lenses may be installed after Adjustment Step 4 on page 30.**
- Reverse the procedure to remove the lenses.

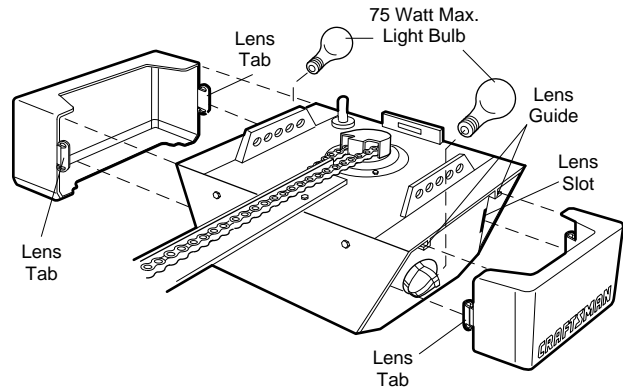

Installation Step 8

Attach the Emergency Release Rope and Handle

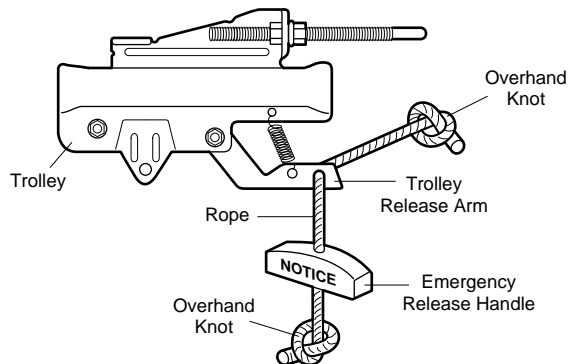

WARNING

Do not use the red handle to pull the door open or closed. *The rope knot could become untied and you could fall.* Use the emergency release only to disengage the trolley and, if possible, only when the door is closed.

Garage doors are heavy. If the door is open when the handle is pulled, the door could close inadvertently if it is not properly balanced. Serious injury may result to persons under the door. Make sure the doorway is clear of persons and obstructions before pulling handle when door is open.

- Thread one end of the rope through the hole in the top of the red handle so "NOTICE" reads right side up as shown. Secure with an overhand knot.
The knot should be at least 1" from the end of the rope to prevent slipping.
 - Thread the other end of the rope through the hole in the release arm of the outer trolley.
 - Adjust rope length so the handle is 6 feet above the floor. Secure with an overhand knot .
- If it is necessary to cut the rope, heat seal the cut end with a match or lighter to prevent unraveling.**

Installation Step 9

Electrical Requirements

To reduce the risk of electric shock, your garage door opener has a grounding type plug with a third grounding pin. This plug will *only* fit into a grounding type outlet.

If the plug doesn't fit into the outlet you have, contact a qualified electrician to install the proper outlet.

To avoid installation difficulties, do not run the opener at this time.



WARNING

To prevent electrocution or fire, installation and wiring must be in compliance with local electrical and building codes.

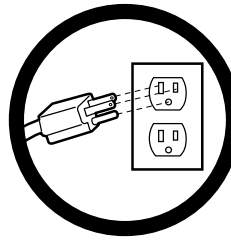

Right

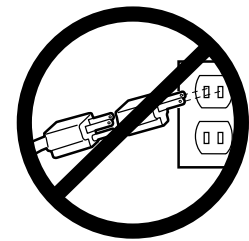

Wrong

- Do not change the plug in any way.
- Do not use a 2-wire adapter.
- Do not use an extension cord.

If permanent wiring is required by your local code, refer to the following procedure:



WARNING

To prevent electrocution, remove power from the garage door opener *and* from the circuit you plan to use for the permanent connection.

- To make a permanent connection through the 7/8" diameter hole in the top of the opener (according to local code):
- Remove the opener cover screws and set the cover aside.
- Remove the attached 3-prong cord.
- Connect the black (line) wire to the screw on the brass terminal; the white (neutral) wire to the screw on the silver terminal; and the ground wire to the green ground screw. **The opener must be grounded.**
- Reinstall the cover.

To avoid installation difficulties, do not run the opener at this time.

Permanent Wiring Connection

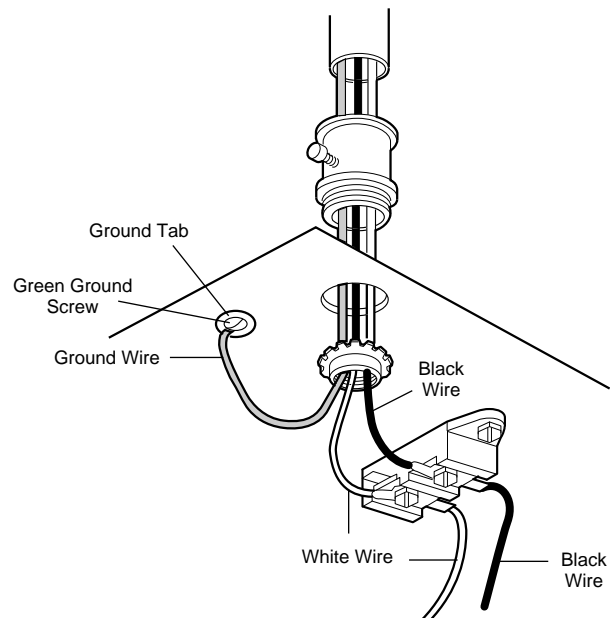

Information you'll need before you begin the installation of the safety reversing sensor.

The safety reversing sensor *must* be connected and aligned correctly before the garage door opener will move in the down direction. This is a required safety device and cannot be disabled.

Installation procedures are the same for sectional and one-piece doors.



WARNING

Without a properly working safety reversing sensor, persons (particularly children) could be injured or killed by a closing garage door. Read and follow all instructions.

To protect small children, install the safety reversing sensor so that the beam will be no higher than 4"-6" above the garage floor.

Disconnect power to the garage door opener before installing the safety reversing sensor.

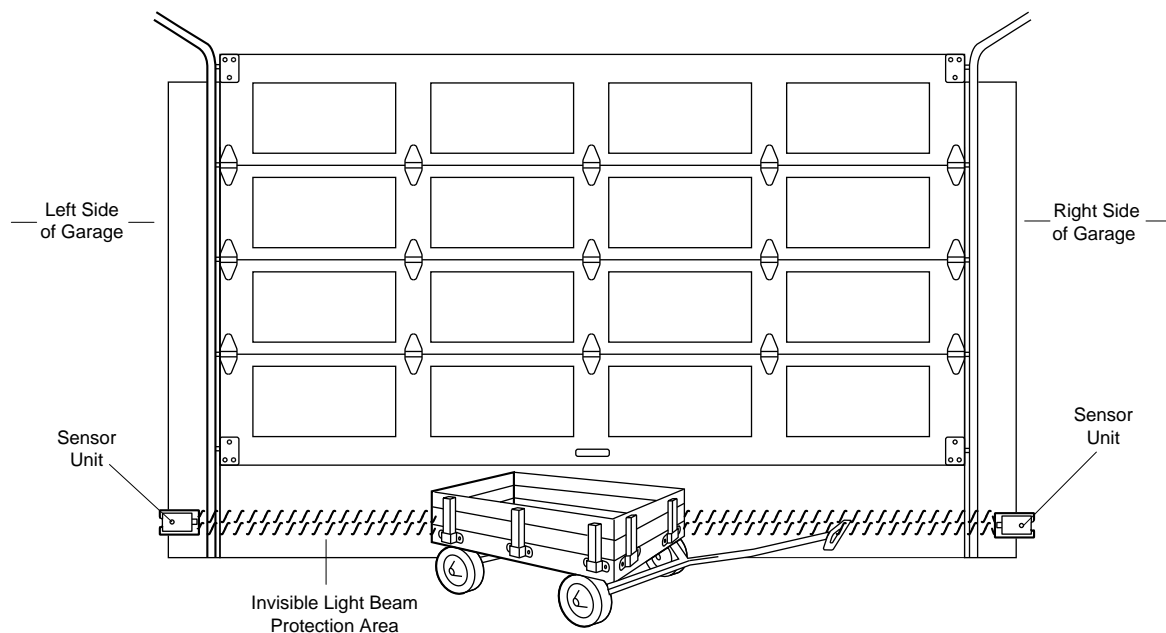

Figure 1: Facing the door from inside the garage

Be sure power to the opener is disconnected.

The sending eye transmits an invisible light beam to the receiving eye. The units can be installed on either side of the garage door as long as the sun never shines directly into the receiving eye lens.

Look at the label on the connector end of each case to identify the sensors.

The brackets must be connected and fastened so that the sending and receiving eyes face each other as shown in Figure 1.

If an obstruction breaks the light beam while the garage door is closing, the door will stop and reverse to full open position, and the opener lights will flash for 5 seconds.

The brackets *must* be securely fastened to a solid surface such as the studs on either side of the door, or add a piece of wood at each location if installing in masonry construction.

The invisible light beam path must be unobstructed. No part of the garage door (or door tracks, springs, hinges, rollers or other hardware) can interrupt the beam while the door is closing. If it does, use a piece of wood to build out each sensor mounting location to the minimum depth required for light beam clearance.

Installation Step 10

Install the Safety Reversing Sensor

Figures 2 and 3 show assembly of brackets and "C" wrap based on the recommended installation of the sensors as shown on page 21.

However, Figures 4 and 5 show variations which may fit your installation requirements better. **Make sure the wraps and brackets are aligned so the sensors will face each other across the garage door.**

- Fasten the "C" wraps to the mounting brackets having square holes, using the hardware shown in Figure 2.
- Connect each assembly to a slotted bracket, using the hardware shown in Figure 3.

Note the alignment of the brackets for left and right sides of the door.

- Finger tighten the lock nuts.
- Use bracket mounting holes as a template to locate and drill (2) 3/16" diameter pilot holes on both sides of the garage door, 4"-6" above the floor **but not exceeding 6"**. (See warning on page 21).
- Attach bracket assemblies with 1/4"x1-1/2" lag screws as shown in Figure 3.
- Adjust right and left side bracket assemblies to the same distance out from the mounting surface. Make sure all door hardware obstructions are cleared. Tighten the nuts securely.

Figure 2

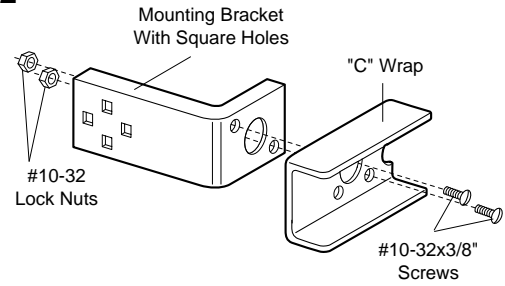
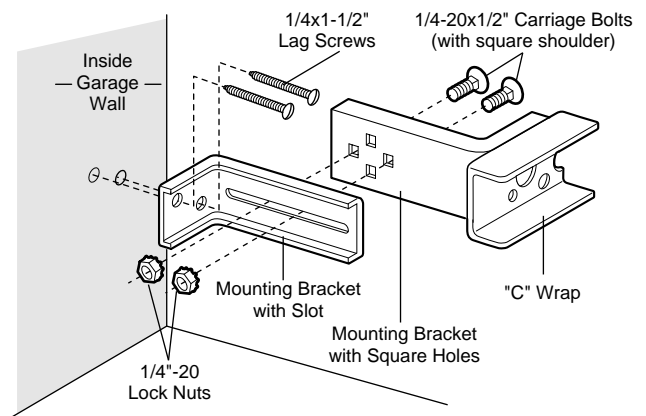
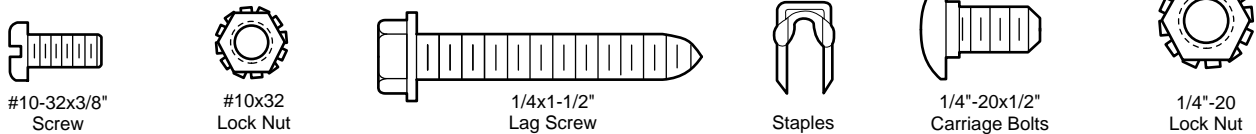

Figure 3



Hardware Shown Actual Size



Alternate Wall Mount

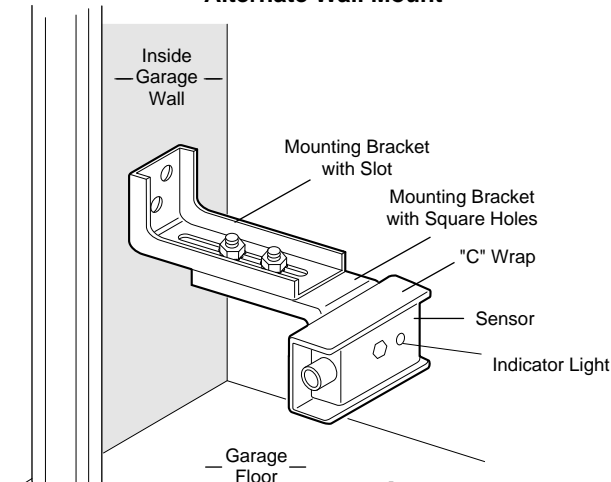

Figure 4

Alternate Floor Mount

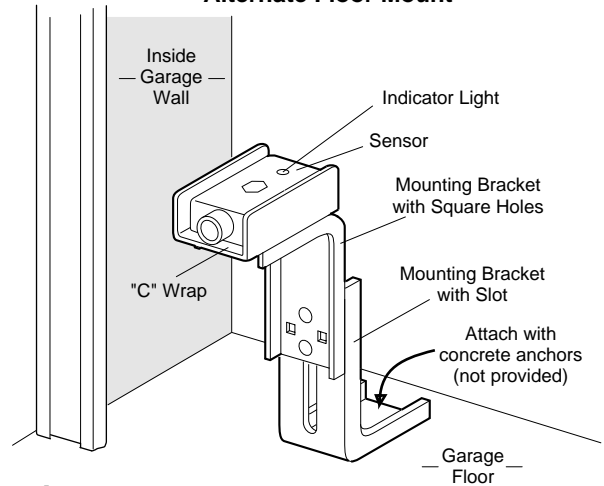

Figure 5

- Insert the wire connector into each sensor and push until you hear a click (Figure 6). The white tab on the sensor should be flush with the back of the connector.

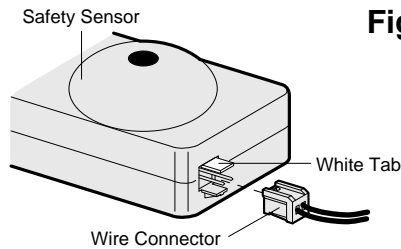

Figure 6

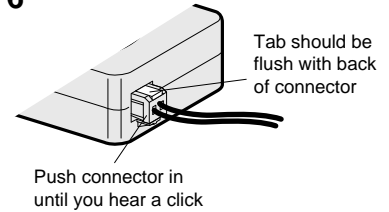
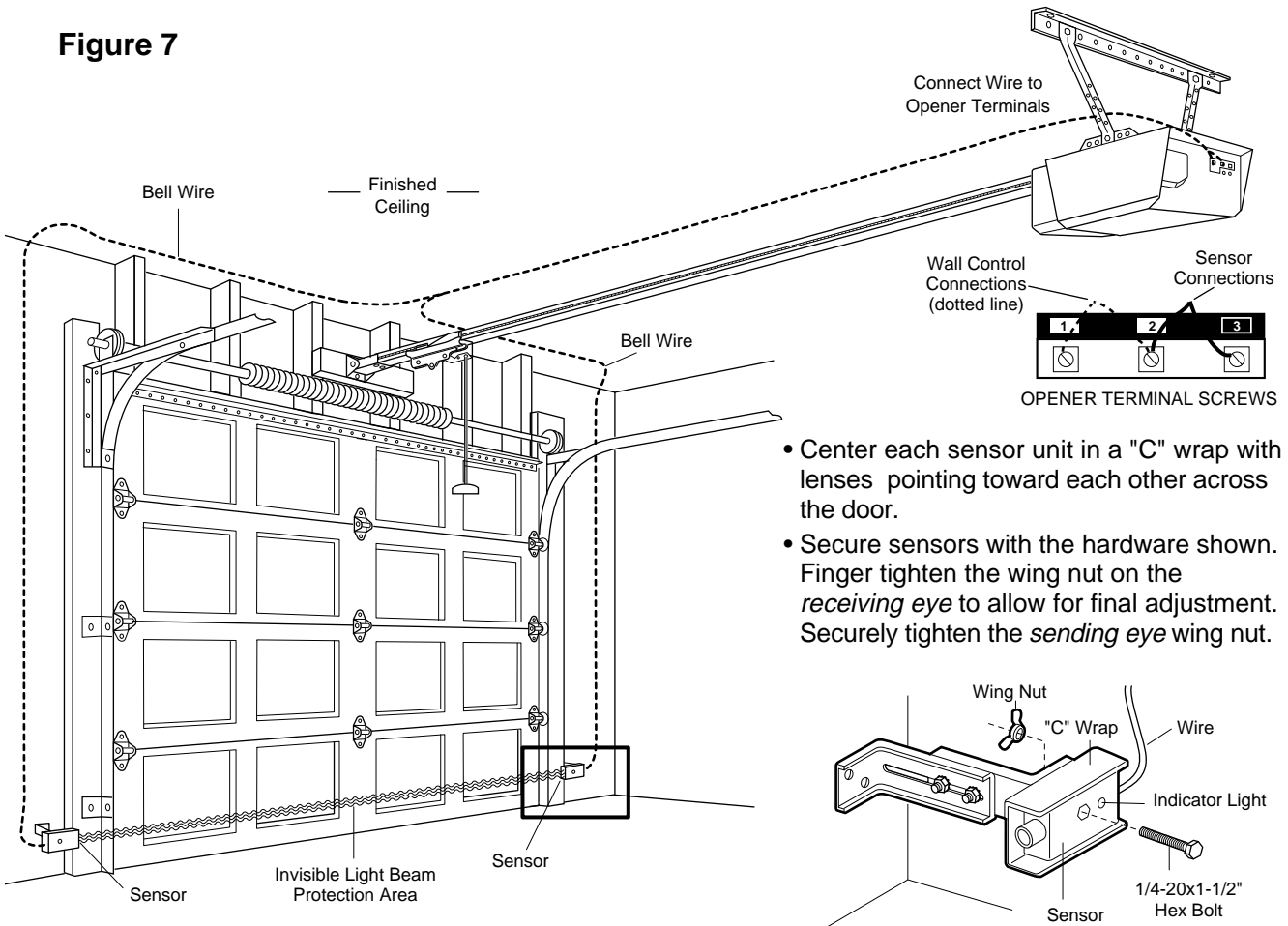

Figure 7



- Center each sensor unit in a "C" wrap with lenses pointing toward each other across the door.
- Secure sensors with the hardware shown. Finger tighten the wing nut on the *receiving eye* to allow for final adjustment. Securely tighten the *sending eye* wing nut.

- Run paired wires from both sensors to the opener. Use insulated staples to secure the wire to the wall and ceiling.
- Strip 1/4" of insulation from each set of wires. Separate white and white/black wires sufficiently to connect to the opener terminal screws: white to 2 and white/black to 3.
- Plug in the opener. Green indicator lights in both the sending and receiving eyes will *glow steadily* if wiring connections and alignment are correct. If the indicator light is *off* in the *receiving eye* (and the invisible light beam path is not obstructed), alignment is required.
- Loosen the receiving eye wing nut to allow slight rotation of unit. Adjust sensor vertically and horizontally until the green indicator light *glows with a steady light*.
- When indicator lights are *glowing steadily* in both units, tighten the wing nut in the receiving eye unit.

Trouble Shooting

1. If the *sending eye* indicator light does not *glow steadily* after installation, check for:
 - Electric power to the opener.
 - A short in the white or white/black wires. These can occur under staples or at screw terminal connections.
 - Incorrect wiring between sensors and opener.
 - An open wire (wire break).
2. If the sending eye indicator light *glows steadily* but the receiving eye indicator light doesn't:
 - Check alignment.
 - Check for an open wire to the receiving eye.

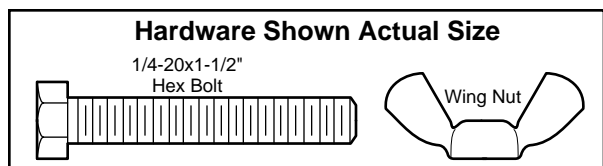

Installation Step 11

Fasten Door Bracket

Follow instructions which apply to your door type as illustrated below or on page 25.



CAUTION

To prevent damage to steel, aluminum, fiberglass or glass panel doors, always reinforce the inside of the door both vertically and horizontally with an angle iron.

A horizontal brace should be long enough to be secured to 2 vertical supports. A vertical brace should cover the height of the top panel.

The illustration shows one piece of angle iron as the horizontal brace. For the vertical brace, 2 pieces of angle iron are used to create a "U"-shaped support. The best solution is to check with your garage door manufacturer for an opener installation, door reinforcement kit.

SECTIONAL Door Installation Procedure

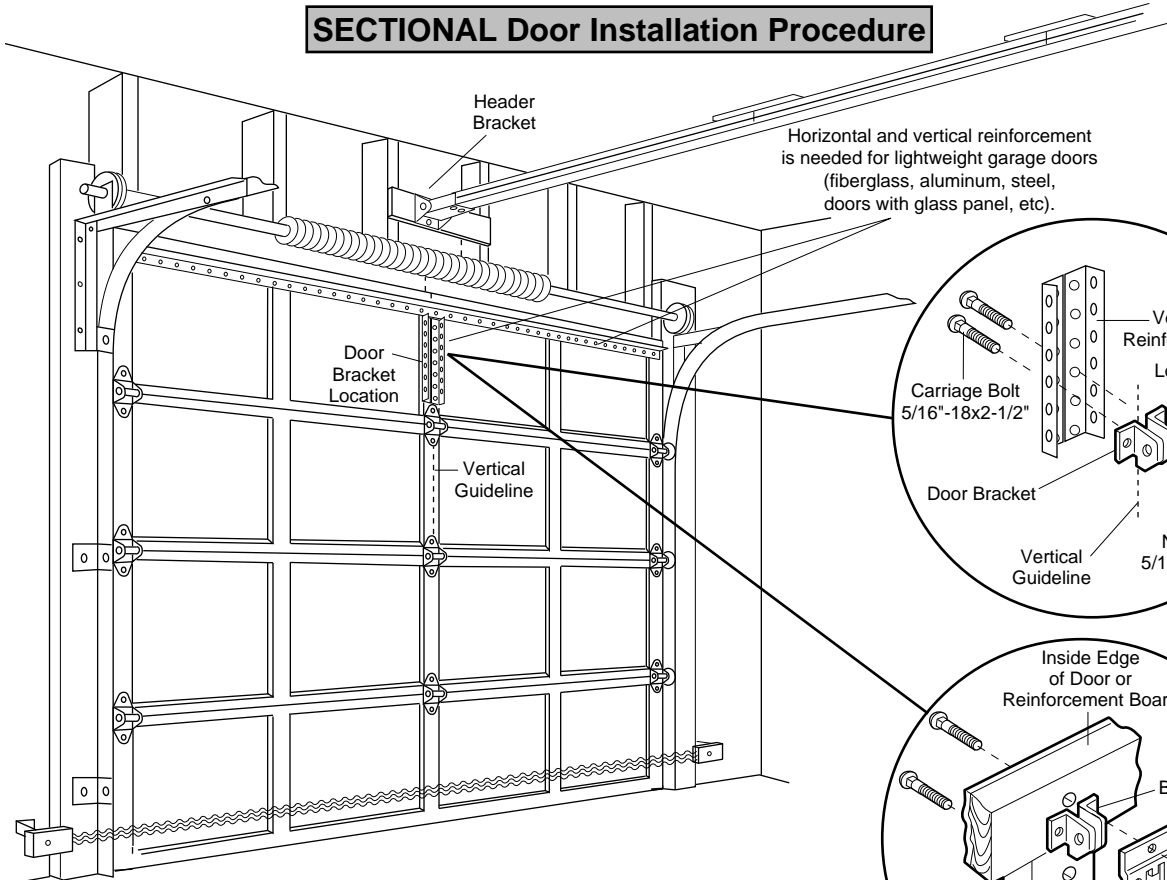

Figure 1

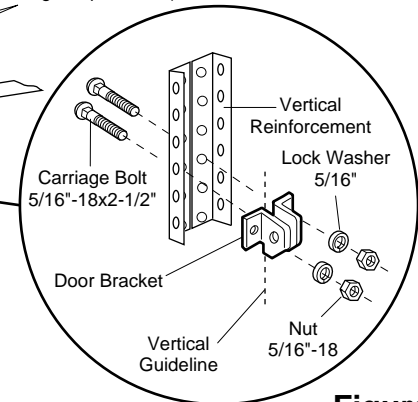
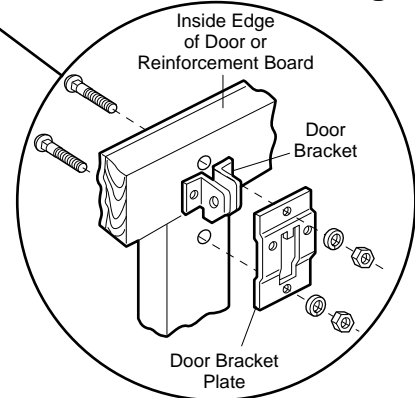

Figure 2



- Center the door bracket on the previously marked vertical guideline used for the header bracket installation.
- Position the bracket on the face of the door within the following limits:
 - A) The top edge of the bracket 2"-4" below the top edge of the door.
 - B) The top edge of the bracket directly below any structural support across the top of the door.
- Mark and drill 5/16" left and right fastening holes. Secure the bracket as shown in Figure 1 if there is vertical reinforcement.

If your installation doesn't require vertical reinforcement but does need top and bottom fastening holes for the door bracket, position the door plate over the door bracket as shown in Figure 2. Fasten securely with hardware shown in Figure 1.

Hardware Shown Actual Size



Nut 5/16"-18



Lock Washer 5/16"

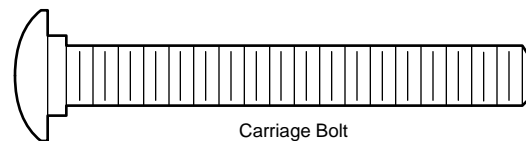

Carriage Bolt
5/16"-18x2-1/2"

All ONE-PIECE Door Installation Procedure

Please read and comply with the warnings and reinforcement instructions on page 24. They apply to one-piece doors also.

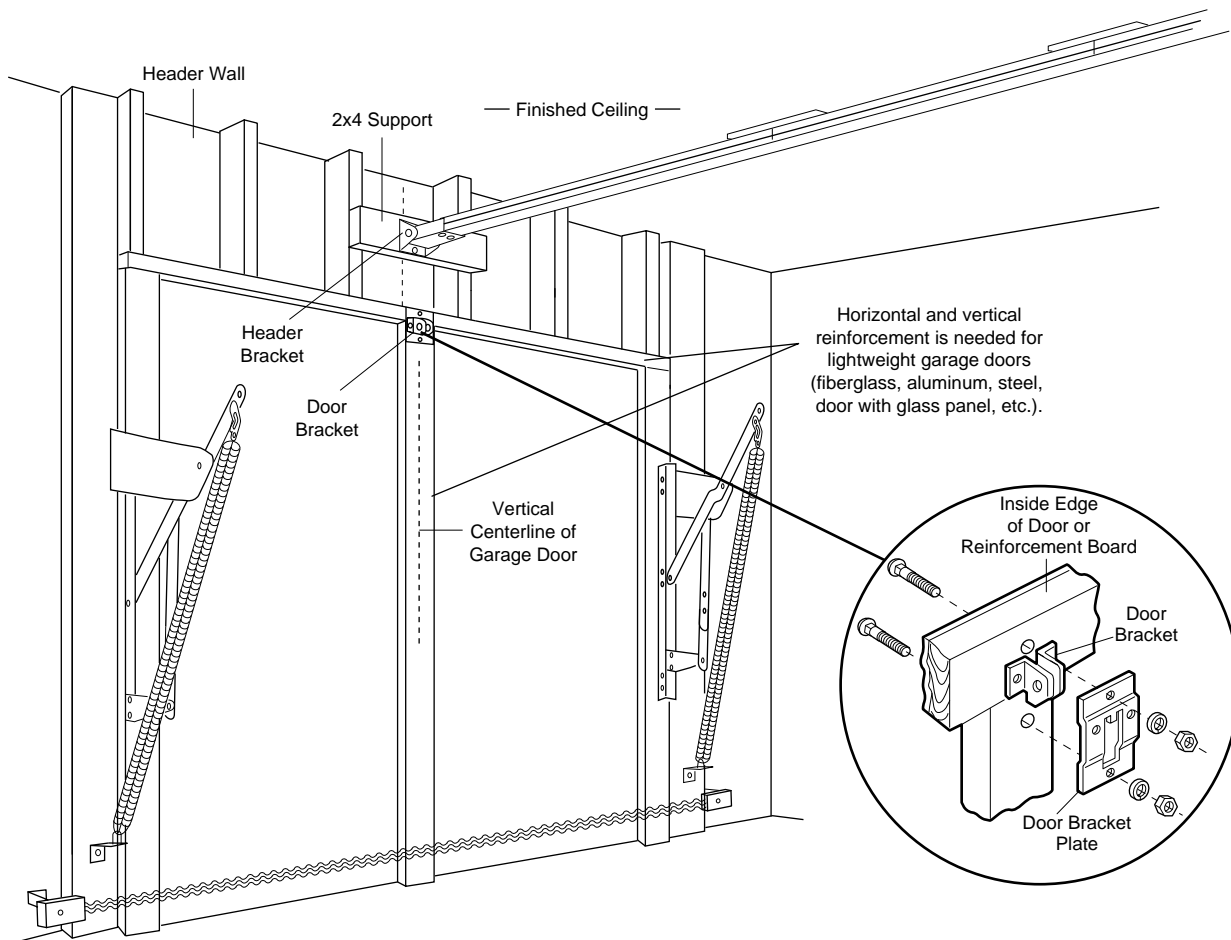

Horizontal and vertical reinforcement is needed for lightweight garage doors (fiberglass, aluminum, steel, door with glass panel, etc.).

- Center the bracket (with or without the plate according to your fastening requirements) on the inside face of the door, in line with the header bracket as shown. Mark either the left and right, or the top and bottom holes.
- Drill 5/16" pilot holes and fasten the door bracket with hardware supplied.

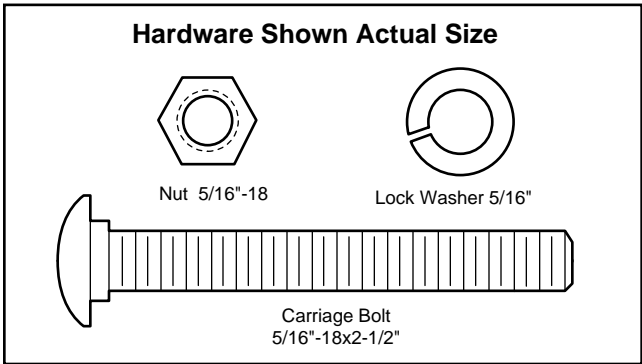

Installation Step 12

Connect Door Arm to Trolley

Follow instructions which apply to your door type as illustrated.

SECTIONAL Doors Only

Make sure garage door is fully closed. Pull the emergency release handle to disconnect the outer trolley from the inner trolley. Slide the outer trolley back (away from the door) about 2" as shown in Figures 1, 2 and 3.

Figure 1:

- Fasten straight door arm section to outer trolley with a clevis pin. Secure the connection with a ring fastener.
- Fasten curved section to the door bracket in the same way as shown.

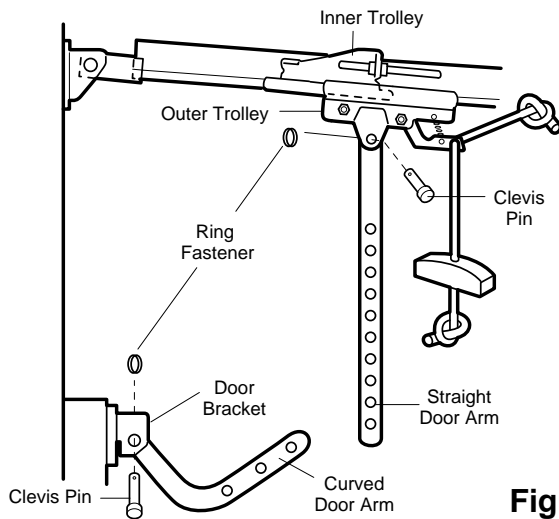

Figure 1

Figure 2:

- Bring arm sections together. Find two pairs of holes that line up and join sections. Select holes as far apart as possible to increase door arm rigidity.

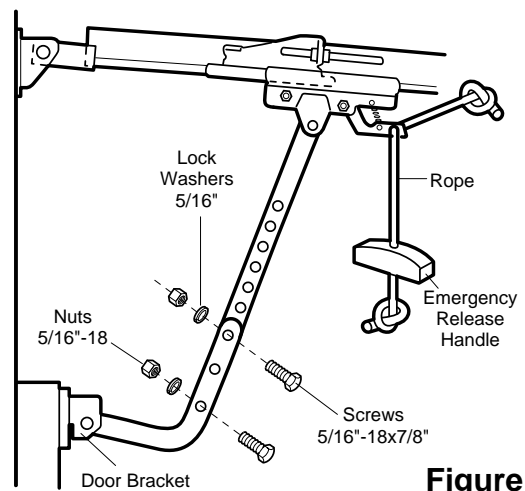

Figure 2

Hole Alignment Alternative

Figure 3:

- If holes in curved arm are *above* holes in straight arm, disconnect straight arm. Cut about 6" from the solid end. Reconnect to trolley with *cut end down* as shown.
- Bring arm sections together.
- Find two pairs of holes that line up and join with screws, lock washers and nuts.

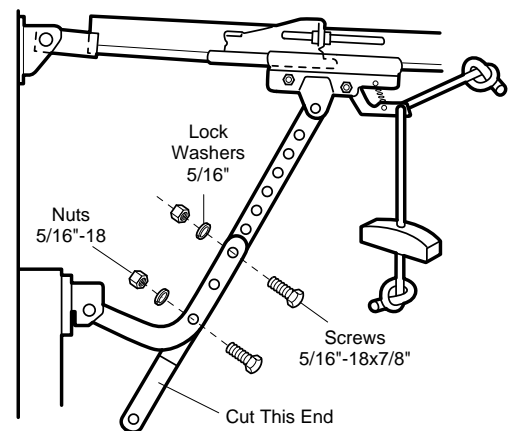
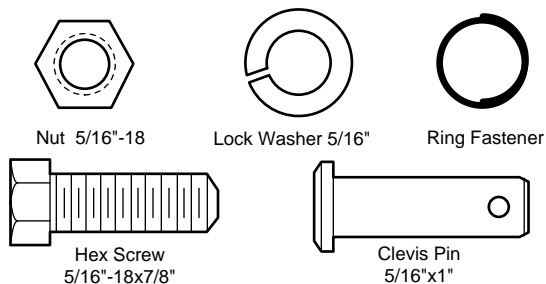

Figure 3

Hardware Shown Actual Size



Proceed to Adjustment Step 1, page 28. Trolley will re-engage automatically when the opener is operated.

All ONE-PIECE Doors

Assemble the Door Arm:

- Fasten the straight and curved door arm sections together to the longest possible length (with a 2 or 3 hole overlap).
- With the door closed, connect the straight door arm section to the door bracket with a clevis pin.
- Secure with a ring fastener.

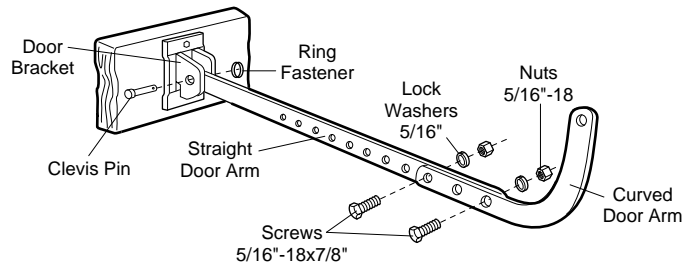

On one-piece doors, before connecting the door arm to the trolley the travel limits must be adjusted. Limit adjustment screws are located on the left side panel as shown on page 28. Follow adjustment procedures below.

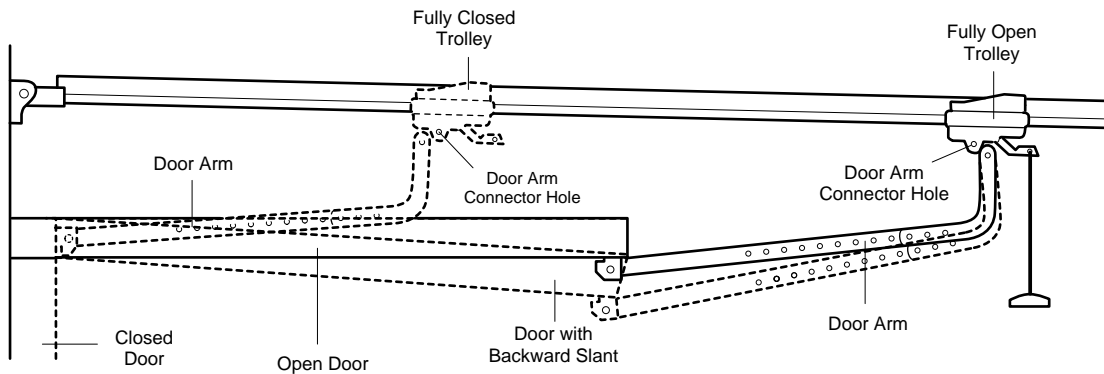

Adjustment Procedures for One-Piece Doors

Open Door Adjustment: Decrease UP limit

- Turn the UP limit adjustment screw counter-clockwise 5-1/2 turns.
- Press the Wall Control push bar. The trolley will travel to the fully open position.
- Manually raise the door to the open position (parallel to the floor), and lift the door arm to the trolley. The arm should touch the trolley just in back of the door arm connector hole. Refer to the fully open trolley/door arm positions in the illustration. If the arm does not extend far enough, adjust the limit further. One full turn equals 2" of trolley travel.

Closed Door Adjustment: Decrease DOWN limit

- Turn the DOWN limit adjustment screw clockwise 5 complete turns.
- Press the Wall Control push bar. The trolley will travel to the fully closed position.
- Manually close the door and lift the door arm to the trolley. The arm should touch the trolley just ahead of the door arm connector hole. Refer to the fully closed trolley/door arm positions in the illustration. If the arm is behind the connector hole, adjust the limit further. One full turn equals 2" of trolley travel.

Connect the door arm to the trolley:

- Close the door and join the curved arm to the connector hole in the trolley with the remaining clevis pin. **It may be necessary to lift the door slightly to make the connection.**
- Secure with a ring fastener.
- Run the opener through a complete travel cycle. If the door has a slight "backward" slant in full open position as shown in the illustration, decrease the UP limit until the door is parallel to the floor.

Adjustment Step 1

Adjust the UP and DOWN Limits

Do not make any limit adjustments until the safety reversing sensors are completely installed.

Limit adjustment settings regulate the points at which the door will *stop* when moving up or down. The door will *stop* in the *up* direction if anything interferes with door travel. The door will *reverse* in the *down* direction if anything interferes with the door travel (including binding or unbalanced doors). To operate the opener, press the Wall Control push bar. Run the opener through a complete travel cycle.

- Does the door open and close completely?
- Does the door stay closed and not reverse unintentionally when fully closed?

If your door passes both of these tests, no limit adjustments are necessary.

Adjustment procedures are outlined below. Run the opener through a complete travel cycle after each adjustment.

Repeated operation of the opener during adjustment procedures may cause the motor to overheat and shut off. Simply wait 15 minutes and try again.

Read the procedures carefully before proceeding to Adjustment Step 2. Use a screwdriver to make limit adjustments.

How and When to Adjust the Limits

If the door does not *open completely* but opens at least five feet

Increase *up* travel. Turn the UP limit adjustment screw clockwise. One turn equals 2" of travel.

If door does not open at least 5 feet: Adjust the UP (open) force as explained in Adjustment Step 2.

If the door does not *close completely*

Increase *down* travel. Turn the DOWN limit adjustment screw counterclockwise. One turn equals 2" of travel.

If door still won't close completely, try lengthening the door arm, page 26.

If you have adjusted the door arm to the maximum length and the door still will not close completely, lower the header bracket. See Installation Step 1, pages 12 and 13.



WARNING

Improper adjustment of the travel limits will interfere with the proper operation of the safety reverse system. *The door might not reverse when required and could seriously injure or kill someone under it.* Test the safety reverse system following all adjustments to the travel limits. See page 30.

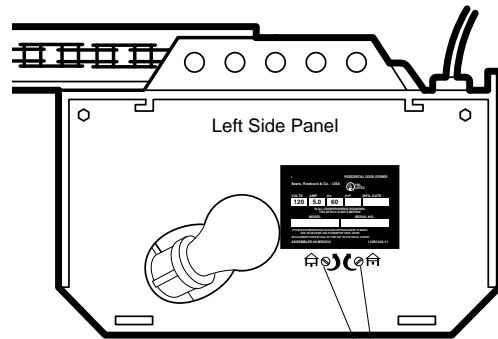

Limit Adjustment Screws



Adjustment Label

If the opener *reverses* in fully closed position

Decrease *down* travel. Turn the DOWN limit adjustment screw clockwise. One turn equals 2" of travel.

If the door *reverses* when closing and there is no visible interference to travel cycle

If the opener lights are flashing, the Safety Reversing Sensor is obstructed. Remove the obstruction.

Test the door for binding: Pull the emergency release handle. Manually open and close the door. If the door is binding, call for garage door service. If the door is not binding or unbalanced, adjust the DOWN (close) force. See Adjustment Step 2.

Adjustment Step 2

Adjust the Force

Force adjustment controls are located on the right side panel of the opener. Force adjustment settings regulate the amount of power required to open and close the door.

The door will *stop* in the *up* direction if anything interferes with its travel. The door will *reverse* in the *down* direction if anything interferes with its travel (including binding or unbalanced doors).

If the forces are set too light, door travel may be interrupted by *nuisance reversals* in the *down* direction and *stops* in the *up* direction. Weather conditions can affect the door movement, so occasional adjustment may be needed.

The maximum force adjustment range is 260 degrees, about 3/4 of a complete turn. Do not force controls beyond that point. Turn force adjustment controls with a screwdriver.

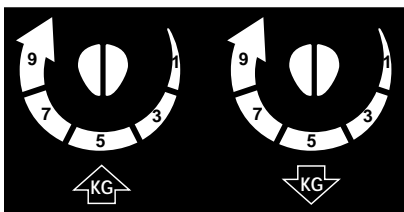

Adjustment Label



WARNING

Too much force on the door will interfere with the proper operation of the safety reverse system. *The door might not reverse properly when required and could seriously injure or kill someone under it.* Do not increase the force beyond the minimum amount required to close the door. Do not use the force adjustments to compensate for a binding or sticking garage door. Test the safety reverse system following all adjustments to force levels. See page 30.

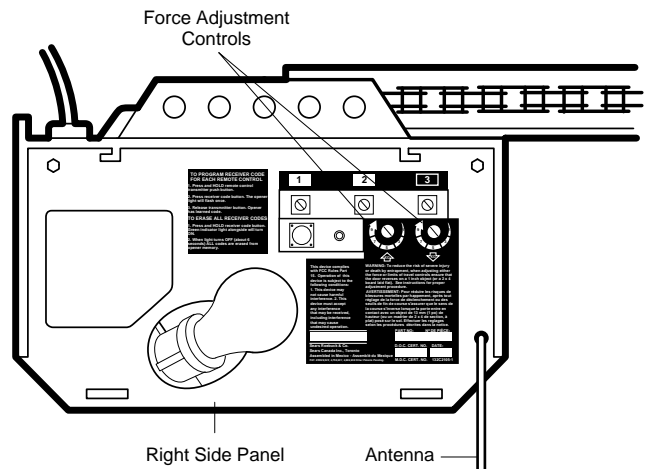

How and When to Adjust the Forces

Test the DOWN (close) force

Grasp the door bottom when the door is about halfway through DOWN (close) travel. The door should reverse. **(Reversal halfway through down travel does not guarantee reversal on a one-inch obstruction. See page 30.)** If the door is hard to hold or doesn't reverse, decrease the DOWN (close) force by turning the control counterclockwise.

Make 10 degree turn adjustments until the door reverses normally. After each adjustment, run the opener through a complete cycle.

Test the UP (open) force

Grasp the door bottom when the door is about halfway through UP (open) travel. The door should stop. If the door is hard to hold or doesn't stop, decrease UP (open) force by turning the control counterclockwise.

Make 10 degree turn adjustments until the door stops easily.

After each adjustment, run the opener through a complete travel cycle.

If the door doesn't open *at least 5 feet*

Increase UP (Open) force by turning the control clockwise. Make 10 degree turn adjustments until door opens completely. Re-adjust the UP limit if necessary. After each adjustment, run the opener through a complete travel cycle.

If the door *reverses during the down (close) cycle and the opener lights aren't flashing*

Increase DOWN (close) force by turning the control clockwise. Make 10 degree turn adjustments until the door completes a close cycle. After each adjustment, run the opener through a complete travel cycle. **Do not increase the force beyond the minimum amount required to close the door.**

Adjustment Step 3

Test The Safety Reversing Sensor

- Press the transmitter push button to open the door.
- Place the opener carton in the path of the door.
- Press the transmitter push button to close the door. *The door will not move more than an inch, and the opener light(s) will flash.*

The garage door opener will not close from a transmitter if the indicator light in either sensor is off (alerting you to the fact that the sensor is misaligned or obstructed).

The garage door can be closed by pressing and holding the Wall Control push bar until down travel is completed.

Professional service is required if the opener closes the door when the safety reversing sensor is obstructed.

**WARNING**

Without a properly working safety reversing sensor, persons (particularly children) could be seriously injured or killed if trapped by a closing garage door. Repeat this test once a month.

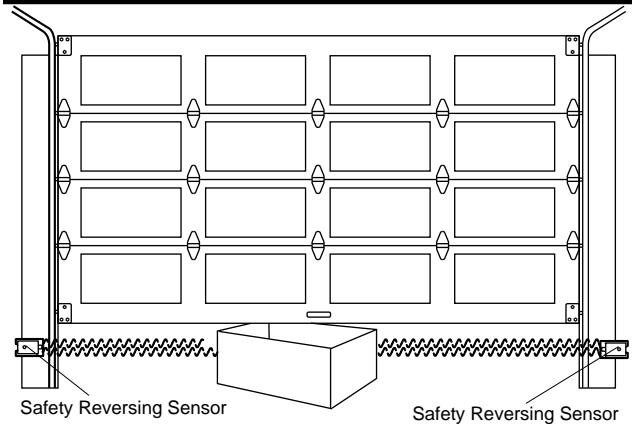

Adjustment Step 4

Test the Safety Reverse System

TEST:

- Place a 2x4 laid flat on the floor, centered under the garage door.
- Operate the door in the down direction. **The door must reverse on striking the obstruction.**

ADJUSTMENT:

If the door *stops* on the obstruction, it is not traveling far enough in the down direction.

- Increase the DOWN limit by turning the DOWN limit adjustment screw counterclockwise 1/4 turn.
- Repeat the test.

On a sectional door, make sure limit adjustments do not force the door arm beyond a straight up and down position. See the illustration on page 26.

- When the door reverses on the 2x4, remove the obstruction and run the opener through 3 or 4 complete travel cycles to test adjustment.

If the door will not reverse after repeated adjustment attempts, call Sears Service Center for garage door opener service.

**WARNING**

Failure to test and adjust the safety reverse system may result in serious injury or death from a closing garage door. Repeat this test once a month and adjust as needed.

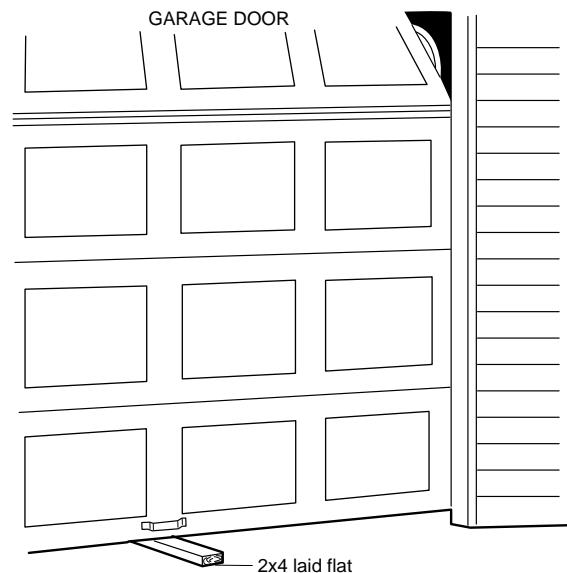

Important safety check

Repeat Adjustment Steps 1, 2 and 4 after:

- Each adjustment of door arm length, force controls or limit controls.
- Any repair to or adjustment of the garage door (including springs and hardware).
- Any repair to or buckling of the garage floor.
- Any repair to or adjustment of the opener.

IMPORTANT SAFETY INSTRUCTIONS



WARNING



WARNING

To reduce the risk of severe injury or death to persons:

1. READ AND FOLLOW ALL INSTRUCTIONS.
2. Do not permit children either to operate or to play with the opener. Keep remote control in a location inaccessible to children.
3. Operate opener only when the door is in full view and free from any obstruction. Keep the door in sight until it is completely closed. **NO ONE SHOULD CROSS THE PATH OF THE MOVING DOOR.**
4. Check safety reversal system monthly. See page 30. The garage door **MUST** reverse on contact with a 2x4 board laid flat on the floor. If an adjustment is made to either the force or the limit of travel, both adjustments may be needed and the safety reversal system must be checked. *Failure to properly adjust the opener may result in severe injury or death.*
5. If possible, use the emergency release only when the door is in a closed position. Caution should be taken whenever the disconnect cord is actuated with the door open. *Weak or broken springs may cause the door to fall rapidly, causing injury or death to persons.*
6. **KEEP GARAGE DOORS PROPERLY BALANCED.** See page 3. *An improperly balanced door may not reverse when required and could result in severe injury or death.* Repairs to cables, spring assemblies and other hardware must be made by a professional garage person.
7. Disconnect the electric power to the garage door opener before making any repairs or removing the covers.
8. **SAVE THESE INSTRUCTIONS.**

Care of Your Opener

Limit and force adjustment controls

Limit Controls



Adjustment Label
(Located on the
left side panel)

Force Controls

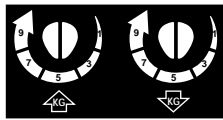

Adjustment Label
(Located on the
right side panel)

Weather conditions may cause some minor changes in door operation requiring some re-adjustments, particularly during the first year of operation.

Pages 28 and 29 refer to the limit and force adjustments. Only a screwdriver is required. Follow the instructions carefully.

Repeat the safety reverse test (page 30) after any adjustment of limits or force.

The remote control transmitter

The opener must learn the code of any new transmitter. Page 33 explains how to program your garage door opener and how to erase all codes if required. Self service of your receiver and transmitter(s) is not recommended. If service is needed, contact your nearest Sears Service Center.

The transmitter battery

The green test light should glow and the opener should operate when the transmitter is activated. If the green test light is *dim or does not come on*, replace the battery.

The 12V battery should produce power for at least a year.

Dispose of your old battery properly.

Maintenance Schedule

Once a Month

Manually operate door. If it is unbalanced or binding, call for professional garage door service.

Check to be sure door opens & closes fully. Adjust limits and/or force if necessary. (See pages 28 and 29.)

Repeat the safety reverse test. Make any necessary adjustments (See page 30).

Twice a Year

Check chain tension. Disconnect trolley first. Adjust if necessary (See page 11).

Once a Year

Oil door rollers, bearings and hinges. The opener does not require additional lubrication.

Do not grease the door tracks.

Operation of Your Opener

Activate the opener with any of the following devices:

- **The 3-Function Transmitter.** Hold *large* push button down until the door starts to move.
- **The Wall Control.** Hold push bar down until the door starts to move.
- **The Key Switch or Touch Code Transmitter** (See Accessories)

When the opener is activated with the safety reversing sensor installed and correctly aligned:

1. If open, the door will close. If closed, the door will open.
2. If closing, the door will reverse.
3. If opening, the door will stop (allowing space for entry and exit of pets and for fresh air).
4. If the door has been stopped in a partially open position, it will close.
5. If obstructed while closing, the door will reverse.
6. If obstructed while opening, the door will stop.
7. The garage door will reverse in the closing cycle when the invisible beam is broken. If fully open, the door will not close when the beam is broken. The sensor has no effect in the opening cycle.

If the sensor is not installed, or is not aligned correctly, the door won't close from any portable transmitter. You can close the door with the Wall Control, the Key Switch, or Touch Code Transmitter; however, if you activate them until down travel is complete. If you release them too soon, the door will reverse.

The opener lights will *blink for 5 seconds* when the safety reversing sensor causes the door to reverse.

Opener Lights will turn on under the following conditions: When the opener is initially plugged in; when the power is interrupted; when the opener is activated. They will turn off automatically after 4-1/2 minutes or provide constant light when the Light feature is activated. Bulb size is 75 watts maximum.



WARNING

Weak or broken springs could allow an open door to fall (either rapidly or unexpectedly), resulting in serious injury, death or property damage. If possible, use the emergency release rope and handle *only* when the door is fully closed.

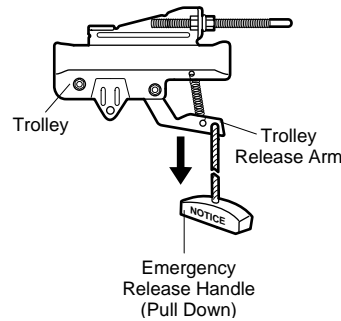

Manual disconnect position

To open the door manually:

The door should be fully closed if possible. Pull down on the red emergency release handle and lift the door manually. To reconnect the door to the opener, press the Wall Control push bar.

The lockout feature prevents the trolley from reconnecting automatically. Pull the emergency handle down and back (toward the opener). The door can then be raised and lowered manually as often as necessary. To disengage the Lockout Feature, pull the emergency handle straight down. The trolley will reconnect on the next UP or DOWN operation.

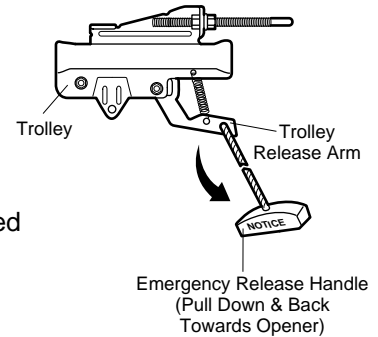

Lockout position

Operation of the Deluxe Lighted Console Wall Control

Lighted Push Bar:

Press to open or close the door.

Press again to *reverse* the door during the closing cycle or to *stop* the door while it's opening.

Light Feature:

Press the Light button. If the opener light is *off*, it will turn *on*.

If the opener light is *on*, (even in the 4-1/2 minute automatic cycle) it will turn *off*.

But if you use the Light button to turn the light(s) *on* and then activate the opener, the light(s) will turn *off* after 4-1/2 minutes.

The Light button will not control the opener lights when the door is in motion.

Lock Feature:

The Lock feature is designed to prevent operation of the door from portable transmitters. However, the door will *open and close* from the Wall Control push bar, the Key Switch and the Touch Code Transmitter.

To Activate:

Press and hold the Lock button for 2 seconds. The push bar indicator light will flash as long as the Lock feature is *on*.

To turn off:

Press and hold the Lock button again for 2 seconds. The push bar indicator light will stop flashing. Normal operation will resume. The Lock feature will also turn off whenever the SRT button on the opener

Receiver and Transmitter Programming

To comply with FCC/IC rules, adjustment or modifications of this receiver and/or transmitter are prohibited, except for changing the code setting or replacing the battery. THERE ARE NO OTHER USER SERVICEABLE PARTS.

Your 18800 series garage door opener (with receiver "SRT" button) has been factory set to operate with the *large* push button on the transmitter(s). However, you can use either of the two small buttons, if you prefer. And, the 3-function transmitter(s) can also activate other garage door openers.

Below are instructions for programming your opener to match the other buttons on your transmitters and any additional transmitters you may purchase. See available accessories on page 38.



WARNING

Children operating or playing with a garage door opener can injure themselves or others. *The garage door could close and cause serious injury or death.* Do not allow children to operate the wall push button(s) or remote control transmitter(s).

A moving garage door could injure or kill someone under it. Activate the opener only when you can see the door clearly, it is free of obstructions, and is properly adjusted.

18800 Series Garage Door Openers (With "SRT" Button)

Your garage door opener will learn and respond to up to 6 transmitter codes:

- A. Up to 4 "SRT" portable transmitters, Item Nos. 18305, 18306 or 18307.
- B. One 390MHz, 19,683 code transmitter, Item Nos. 18778 or 18779.
- C. One Touch Code Transmitter, Item No. 18776.

To Add A Transmitter

1. Select a transmitter push button to operate the receiver.
2. Press and *hold* the selected transmitter push button, Figure 1.
3. Then press and release the "SRT" button on the right side panel of the opener, Figure 2. The opener light will *flash once*.

Now the opener will operate when the transmitter push button is pressed.

If you release the transmitter push button before the opener light flashes, the opener will not accept the code.

To Change the Selected Push Button On the Same Transmitter

If you decide to use a different transmitter button than originally programmed into the opener, you must erase *all* the learned codes and reprogram each transmitter used to operate the garage door opener.

To Erase All Transmitter Codes

- Press and hold the "SRT" button on the opener panel until the indicator light turns off (about 6 seconds). **All the codes the opener has learned will be erased.**
- To reprogram, repeat Steps 1, 2 and 3 for each transmitter in use.

Figure 1

3-Function Transmitter Push Buttons

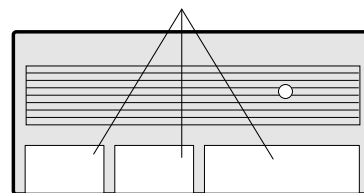

Mini 3-Function Transmitter

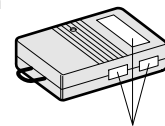

Select a transmitter push button to operate opener

Figure 2

Garage Door Opener Receiver (With "SRT" Button)

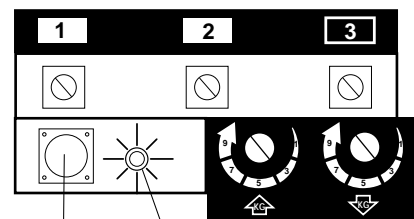

"SRT" Button
Indicator Light

Code programming instructions are also located on the opener panel.

Having a Problem?

Situation	Probable Cause and Solution
<i>The opener doesn't operate from either the Wall Control or the transmitter:</i>	<ol style="list-style-type: none">1. Does the opener have electric power? Plug a lamp into the outlet. If it doesn't light, check the fuse box or the circuit breaker. (Some outlets are controlled by a wall switch.)2. Have you disabled all door locks? Review installation instruction warnings on Page 11.3. Is there a build-up of ice or snow under the door? The door may be frozen to the ground. Remove any restriction.4. The garage door spring may be broken. Have it replaced.5. Repeated operation may have tripped the overload protector in the motor. Wait 15 minutes. Try again.
<i>Opener operates from transmitter, but not from Wall Control:</i>	<ol style="list-style-type: none">1. Is the Wall Control lit? If not, remove the bell wire from the opener terminal screws. Short the red and white terminals by touching both terminals at the same time with a piece of wire. If the opener runs, check for a faulty wire connection at the Wall Control, a short under the staples, or a broken wire.2. Are the wiring connections correct? Review Step 6, page 18.
<i>The door operates from the Wall Control, but not from the transmitter:</i>	<ol style="list-style-type: none">1. If your model has the Lock feature, make sure the lock is Off.2. Is any wall push button flashing? Your opener needs to re-learn a transmitter code. Refer to Instructions on the opener panel.3. Does the battery test light glow when the transmitter push button is pressed? If not, replace the battery.4. Program the receiver to match the transmitter code?5. Repeat the receiver programming procedure with all transmitters.
<i>The transmitter has short range:</i>	<ol style="list-style-type: none">1. Check the battery test light. If the light is dim, replace the battery.2. Change the location of the transmitter in your car.3. Check to be sure the antenna on the side or back panel of opener extends fully downward.4. Some installations may have shorter range due to a metal door, foil backed insulation, or metal garage siding.
<i>Opener noise is disturbing in living quarters of home:</i>	If operational noise is a problem because of proximity of the opener to the living quarters, the Vibration Isolator Kit 41A3263 can be installed. This kit was designed to minimize vibration to the house and is easy to install.
<i>The garage door opens and closes by itself:</i>	<ol style="list-style-type: none">1. Be sure that all transmitter push buttons and battery indicator lights are off.2. Remove the bell wire from the Wall Control terminals and operate from the transmitter only. If this solves the problem, the Wall Control is faulty (replace), or there is an intermittent short in the wire between the Wall Control and the opener.
<i>The door doesn't open completely:</i>	<ol style="list-style-type: none">1. If the door has been working properly but now doesn't open all the way, increase the <i>up force</i>. See page 29.2. Is something obstructing the door?3. If door opens at least 5 feet, the travel limits may need to be increased. One turn equals 2 inches of travel. See page 28. <p><i>Repeat the safety reverse test after the adjustment is complete.</i></p>
<i>The door stops but doesn't close completely:</i>	Review the travel limits adjustment procedures on page 28. <i>Repeat the safety reverse test after any adjustment of door arm length, close force or down limit.</i>

Having a Problem? *(continued)*

Situation	Probable Cause and Solution
<i>The door opens but won't close:</i>	<ol style="list-style-type: none">1. If the opener lights blink, check the safety reversing sensor. See page 23.2. If the opener lights do not blink and it is a new installation, check the down force. See Adjustment Step 2, page 29. For an existing installation, see below. <i>Repeat the safety reverse test after the adjustment is complete.</i>
<i>The door reverses for no apparent reason and opener light doesn't blink:</i>	<ol style="list-style-type: none">1. Is something obstructing the door? Pull the red emergency release handle. Operate the door manually. If it is unbalanced or binding, call a garage door serviceman to correct the problem.2. Clear any ice or snow from the garage floor area where the door closes.3. Review force adjustment procedures on page 29.4. If door reverses in the <i>fully closed</i> position, decrease the travel limits (page 28). <i>Repeat safety reverse test after adjustments to force or travel limits. The need for occasional adjustment of the force and limit settings is normal. Weather conditions in particular can affect door travel.</i>
<i>The door reverses for no apparent reason and opener light blinks for 5 seconds after reversing:</i>	Check the safety reversing sensor. Remove the obstruction or align the receiving eye. See page 23.
<i>The opener light:</i>	<i>... doesn't turn on:</i> Replace the light bulb (75 watts maximum). Use a standard neck garage door opener bulb if regular bulb burns out.
<i>The opener strains or maximum force is needed to operate door:</i>	The door may be out of balance or the springs are broken. Close the door and use the emergency release rope and handle to disconnect the trolley. Open and close the door manually. A properly balanced door will stay in any point of travel while being supported entirely by its springs. If it does not, disconnect the opener and call for a professional garage door service. <i>Do not increase the force to operate the opener.</i>
<i>The opener motor hums briefly, then won't work:</i>	<ol style="list-style-type: none">1. The garage door springs are broken. See above.2. If the problem occurs on the first operation of the opener, door may be locked. <i>Disable the door lock.</i> If the chain was removed and reinstalled, the motor may be out of phase. Remove the chain; cycle the motor to the down position. Observe the drive sprocket. When it turns in a clockwise direction and stops in the down position, reinstall the chain. <i>Repeat the safety reverse test after the adjustment is complete.</i>
<i>The opener won't operate due to power failure:</i>	<ol style="list-style-type: none">1. Use the emergency release rope and handle to disconnect the trolley. The door can be opened and closed manually. When the power is restored, press the Wall Control push bar and trolley will automatically reconnect (unless trolley is in lockout position.) See page 32.2. The Outside Trolley Release accessory (for use on garages with no service door) disconnects the trolley from outside the garage in case of power failure.
<i>The chain droops or sags:</i>	It is normal for the chain to droop slightly in the closed door position. Use the emergency release rope and handle to disconnect the trolley. If the chain returns to normal height when the trolley is disengaged and the door reverses on a 2x4, no adjustments are needed (see page 11).

Repair Parts

Rail Assembly Parts

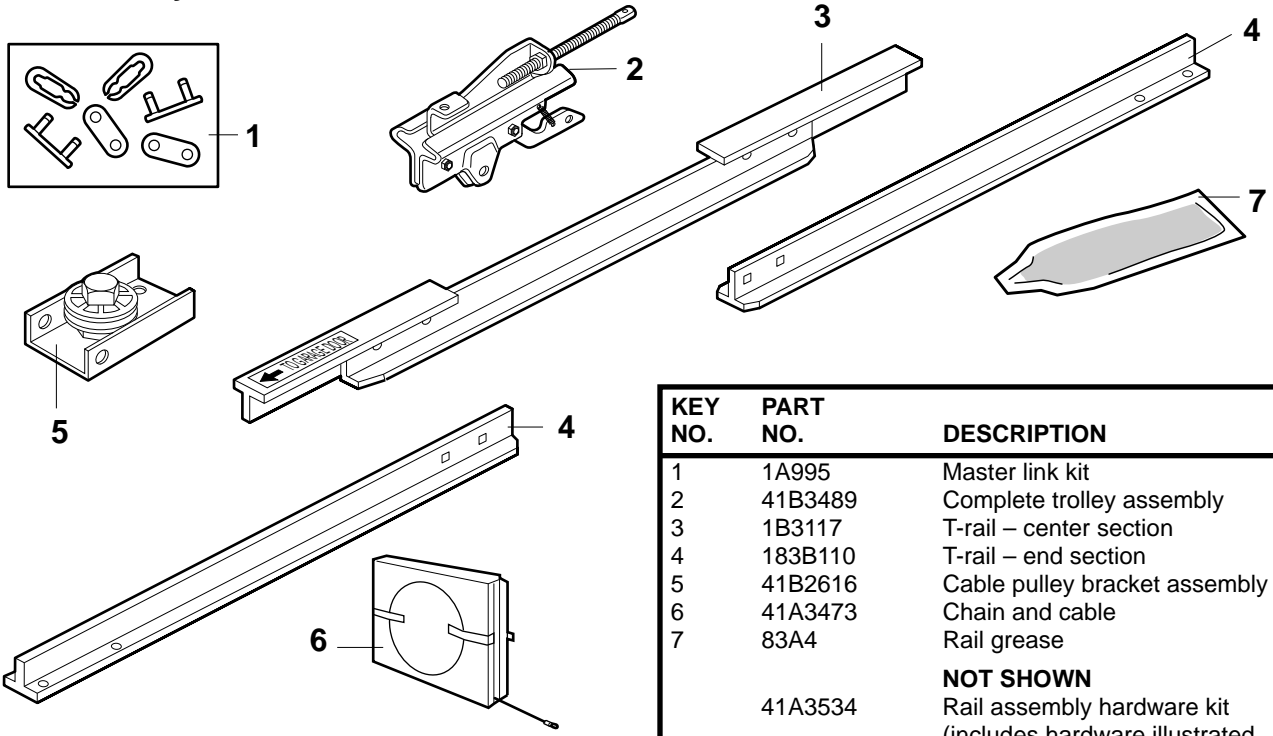

KEY NO.	PART NO.	DESCRIPTION
1	1A995	Master link kit
2	41B3489	Complete trolley assembly
3	1B3117	T-rail – center section
4	183B110	T-rail – end section
5	41B2616	Cable pulley bracket assembly
6	41A3473	Chain and cable
7	83A4	Rail grease
	NOT SHOWN	NOT SHOWN
	41A3534	Rail assembly hardware kit (includes hardware illustrated on page 7).

Installation Parts

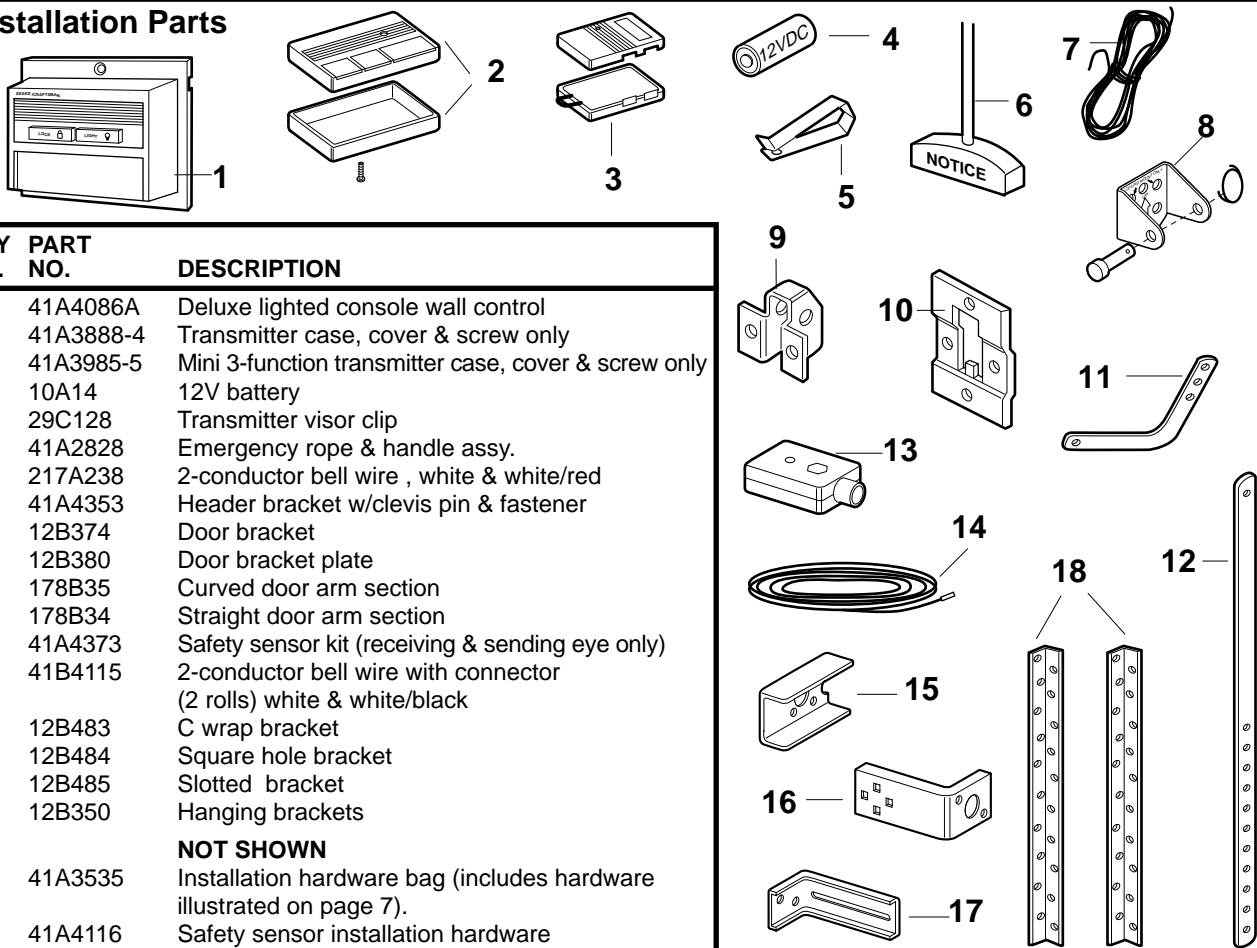

KEY NO.	PART NO.	DESCRIPTION
1	41A4086A	Deluxe lighted console wall control
2	41A3888-4	Transmitter case, cover & screw only
3	41A3985-5	Mini 3-function transmitter case, cover & screw only
4	10A14	12V battery
5	29C128	Transmitter visor clip
6	41A2828	Emergency rope & handle assy.
7	217A238	2-conductor bell wire , white & white/red
8	41A4353	Header bracket w/clevis pin & fastener
9	12B374	Door bracket
10	12B380	Door bracket plate
11	178B35	Curved door arm section
12	178B34	Straight door arm section
13	41A4373	Safety sensor kit (receiving & sending eye only)
14	41B4115	2-conductor bell wire with connector (2 rolls) white & white/black
15	12B483	C wrap bracket
16	12B484	Square hole bracket
17	12B485	Slotted bracket
18	12B350	Hanging brackets
	NOT SHOWN	NOT SHOWN
	41A3535	Installation hardware bag (includes hardware illustrated on page 7).
	41A4116	Safety sensor installation hardware
	114A1860	Owner's manual

Repair Parts

Opener Assembly Parts

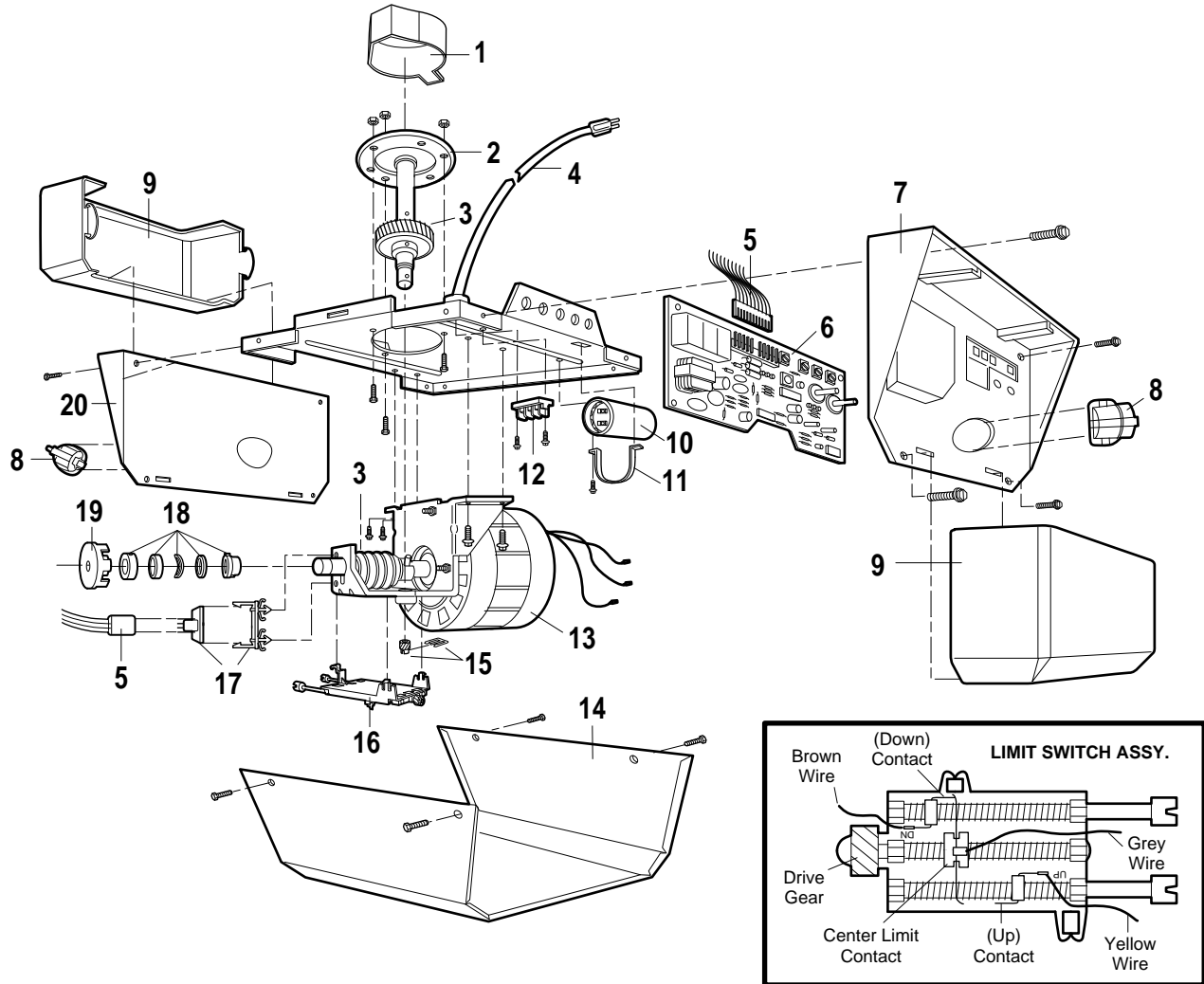

KEY NO.	PART NO.	DESCRIPTION
1	31D380	Sprocket cover
2	41C4220A	Gear and sprocket assy. Complete with: Spring washer Thrust washer Retaining ring Bearing plate Roll pins (2) Drive gear and worm gear Helical gear w/retainer and grease
3	41A2817	Drive/worm gear kit w/grease Roll pins (2)
4	41B4245	Line cord
5	41C4253	Wire harness assy. w/plug
6	41A4315-6B	Receiver logic board assy. Complete with: Logic board End panel w/all labels
7	41A4577	End panel w/all labels
8	175B88	Light socket

KEY NO.	PART NO.	DESCRIPTION
9	108D46	Lens
10	30B363	Capacitor
11	12A373	Capacitor bracket
12	41A3150	Terminal block w/screws
13	41D3058	Universal replacement motor & bracket assembly Complete with: Motor, worm, bracket, bearing assembly, RPM sensor
14	41A3474	Cover
15	41A2818	Helical gear & retainer w/grease
16	41D3452	Limit switch assembly
17	41C4398A	RPM sensor assembly
18	41A2826	Shaft bearing kit
19	41A2822A	Interrupter cup assy.
20	41A4560	End panel
		NOT SHOWN
	41A2825	Opener assembly hardware kit (includes screws not designated by a number in illustration).

Accessories

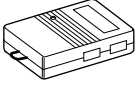
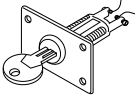
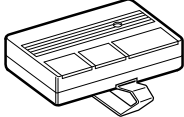
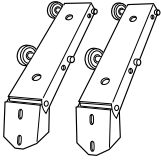
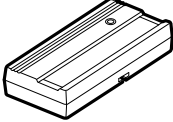
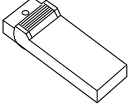
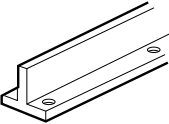
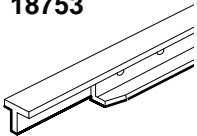
Sears offers many useful accessories for your garage door opener. They are illustrated below with Sears model numbers and descriptions			
<p>18752</p> 	<p>Outside Trolley Release: <i>Required</i> for a garage with NO access door.</p>	<p>18307</p> 	<p>3-Function Mini Transmitter: With key ring & Velcro fastening strip.</p>
<p>18756</p> 	<p>Outdoor Key Switch: Opens the garage door automatically from outside when transmitter is not handy.</p>	<p>18306</p> 	<p>3-Function Standard Size Transmitter Includes visor clip. For operating multiple garage doors.</p>
<p>18785</p> 	<p>Door Clearance Brackets: <i>(For Sectional Doors Only)</i> Replace top brackets and rollers on door to reduce height of door travel. For use when installing opener in garage with low headroom clearance.</p>	<p>18305</p> 	<p>Single-Function Standard Size Transmitter: Includes visor clip.</p>
		<p>18776</p> 	<p>Touch Code Transmitter: Enables homeowner to operate garage door opener from outside by entering code on specially designed keyboard.</p>
<p>18754</p> 	<p>8 ft. Rail Extension: To allow an 8 foot door to open fully.</p>	<p>18753</p> 	<p>10 ft. Rail Extension: To allow a 10 foot door to open fully.</p>

Index

Access Door/Outside Trolley Release Accessory	4, 5
Chain Tension	4, 5, 11
Electrical Safety Warnings	2, 20, 31
Garage Door	
Testing for balance, binding and sticking.....	3, 28, 31
Determining high point of travel:	
Sectional door.....	12
One-piece door.....	13
Disabling existing locks.....	3, 11
Door clearance brackets (for garages with low headroom).....	12, 38
Force controls	
Adjustment procedures.....	29
Problems that might require force adjustments.....	34, 35
Safety warnings.....	29, 31
Door hardware.....	3, 9, 11, 12, 18, 31, 32
Maintenance instruction label.....	11, 28
Reinforcement requirements.....	4, 24
Removing of all ropes.....	3, 11
Possible door damage.....	16, 24
Travel limits	
Adjustment procedures.....	28
Problems that might require limit adjustments.....	34, 35
Safety warnings.....	28, 31
Manual (Emergency) Release Rope & Handle	
Lockout feature.....	32
Manual disconnect.....	32
Safety warnings.....	11, 19, 31, 32
Opener Terminals	
Wall control connections.....	18
Safety reversing sensor connections.....	23
Outdoor key switch accessory connections.....	18
Operational Noise	
Sprocket noise.....	11
Vibration noise (isolator kit).....	34
Receiver and Transmitter	
Programming the receiver.....	33
Erasing all codes.....	33
Activating other openers.....	33
Safety warning.....	33
Problems with transmitter operation.....	34
Safety Reverse Test Procedure	30
Testing required.....	11, 30, 34, 35
Safety reverse system problems	
Securing header bracket to wall.....	12
Adjusting travel limits.....	28
Applying excessive force on the door.....	29
Buckling or uneven floor.....	4, 5
Safety Warnings	2, 3, 9, 11, 12, 16, 18, 19, 20, 21, 24, 28, 29, 30, 31, 32, 33
User Instruction Label for Garage Wall	11, 18

Garage Door Opener Models:

139.18803
139.18805
139.18814
139.18830
139.18850
139.18851

SERVICE AND REPAIR PARTS CALL 1-800-665-4455*

Keep this number handy should you require a service call or need to order repair parts. If ordering parts make sure you have the name, make and model no. of the merchandise and the name and number of the part you wish to order.

THE MODEL NUMBER OF YOUR GARAGE DOOR OPENER IS PRINTED ON A LABEL LOCATED ON THE LEFT SIDE PANEL OF THE OPENER UNDER THE LIGHT LENS.

* If calling locally, please use one of the following numbers

Regina - 566-5124	Montreal - 333-5740
Toronto - 744-4900	Halifax - 454-2444
Kitchener - 894-7590	Ottawa - 738-4440
Vancouver - 420-8211	

MAINTENANCE AGREEMENTS... YOUR WAY TO BUY TOMORROW'S SERVICE AT TODAY'S PRICE...

With nationwide service and the benefits of a Sears warranty plus a Sears maintenance agreement, you don't have to worry about costly repairs resulting from normal use.

The maintenance agreement does not cover installation or re-installation of the product or damage resulting from external causes such as: acts of abuse, fire, flood, wind, lightning, freezing, etc.

To purchase a Sears Maintenance Agreement – ask any salesperson or call Sears Service today.

SEARS WARRANTY

FULL 90 DAY WARRANTY ON GARAGE DOOR OPENER

When the garage door opener is installed, adjusted and operated in accordance with our instructions, Sears will, for a period of 90 days from the date of purchase, repair any defect in workmanship in the garage door opener at no charge.

LIMITED WARRANTY

From the 91st day until one year from the date of purchase, Sears will furnish replacement parts for any defective parts, free of charge. You pay for labor.

LIMITED WARRANTY ON MOTOR

1/2 HP Motor: After 1 year and through 5 years, Sears will furnish replacement parts for any defective parts in motor, free of charge. You pay for labor.

1/3 HP Motor: After 1 year and through 3 years, Sears will furnish replacement parts for any defective parts in motor, free of charge. You pay for labor.

WARRANTY SERVICE IS AVAILABLE BY SIMPLY CONTACTING THE NEAREST SEARS STORE OR SERVICE CENTER

This warranty gives you specific legal rights, and you may also have other rights which vary from province to province.

SEARS CANADA, INC., TORONTO, ONTARIO M5B 2B8