

Owners Manual

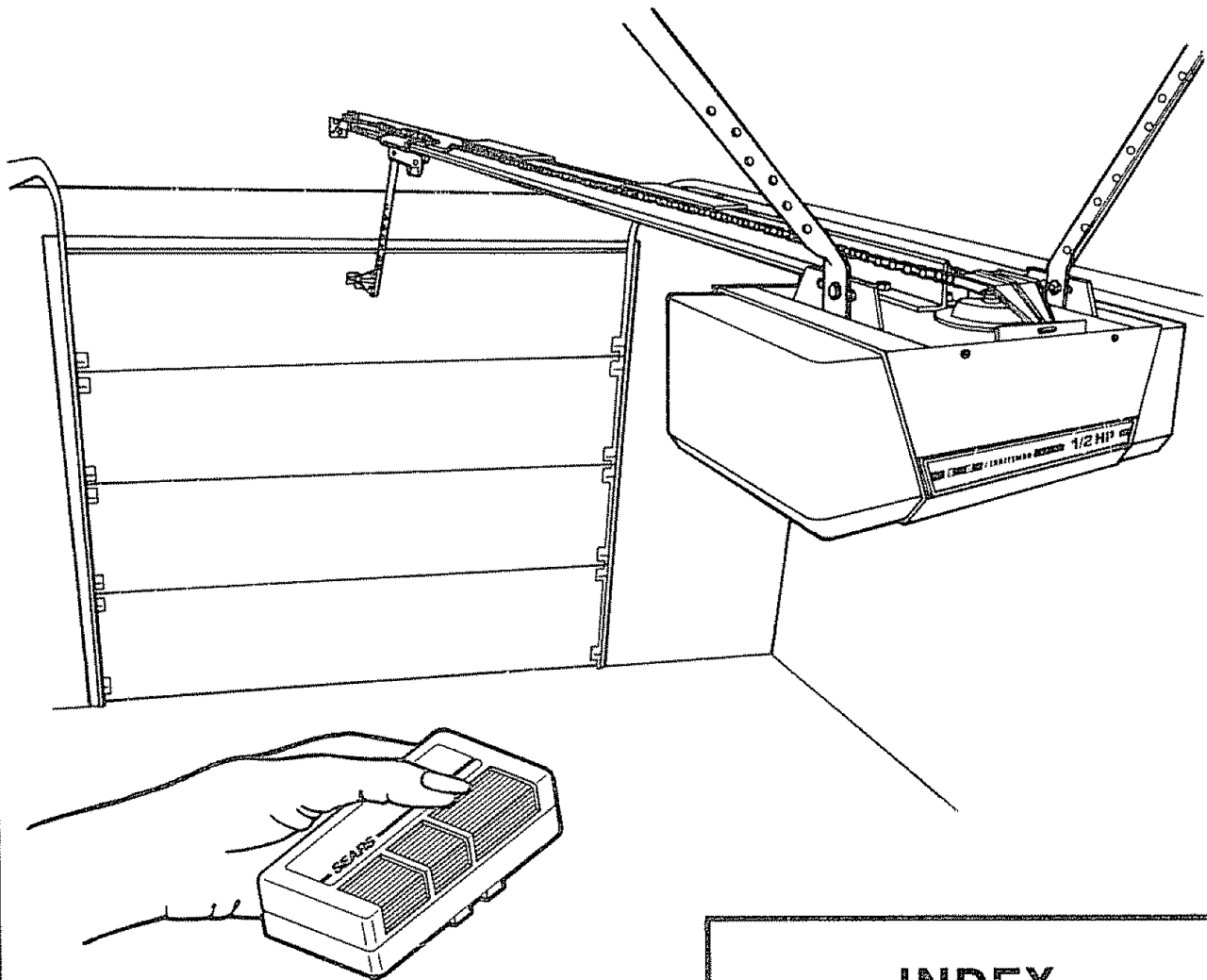

Garage Door Opener Model 139.53513

**CAUTION: READ INSTRUCTIONS AND RULES
FOR SAFE OPERATION CAREFULLY.**

**FASTEN THIS MANUAL NEAR THE GARAGE
DOOR AFTER INSTALLATION. PERIODIC
CHECKS OF OPENER ARE REQUIRED
TO INSURE SATISFACTORY OPERATION.**

INDEX

	Page
Features of Your Opener.....	2
Specifications	2
You'll Need Tools	2
Safety Rules	3
Carton Check List.....	4
Accessories.....	5
Identify Your Door Type.....	5
Assembly	6
Installation.....	10
Adjustment	18
Operation of Your Opener	21
Radio Controls.....	22
Having a Problem?.....	24
Transmitter Schematic	24
Wiring Diagram	25
Receiver Schematic	25
Repair Parts, Rail Assembly	26
Repair Parts, Installation	26
Repair Parts, Chassis Assembly	27
How to Order Repair Parts	28
Maintenance Agreements	28
Sears Warranty.....	28

FEATURES OF YOUR OPENER

- Opener Lights:** Turn on and off automatically with 4-1/2 minute illumination for your safety and convenience. Provide constant light when Work Light control button is pressed.
- Safety System:** Independent up and down force adjustment. Door reverses automatically when obstructed in DOWN direction. Door STOPS when obstructed in UP direction.
- Emergency Disconnect:** Pull cord disconnect permits manual door operation.
- Automatic Reconnect:** Trolley halves reconnect for automatic operation when opener is energized after emergency disconnect.
- Motor Power:** 1/2 horsepower permanently lubricated motor with automatic reset.
- Digital Radio Controls:** 19,683 codes from which to choose. Can be changed easily by the owner.
- 3-Channel Transmitter:** Three push buttons. Each button can activate one or more remote control devices. The large transmitter button is factory preset to operate the garage door opener.
- Easy Limit Adjustment:** Limits of door opening and closing adjusted by turning screws without removing chassis cover.
- Vacation Push Button:** When the Vacation Push Button is ON, the opener will not operate from the transmitter. The door will operate in the UP direction ONLY from the Wall Control (or optional Key Switch accessory, Page 5).

SPECIFICATIONS

MOTOR		SAFETY	
Type	1/2 horsepower, permanent split capacitor	Personal	Push button & automatic reversal in down direction. Push button & automatic stop in up direction
Speed	1500 rpm	Electronic	Independent up & down force adjustment screws
Volts	120 Volts AC - 60 Hz Only	Electrical	Motor overload protector and low voltage push button wiring
Current	4.5 amperes	Limit device	Circuit actuated by limit nut
DRIVE MECHANISM		Limit adjustment	Screwdriver adjustment on side panel
Gear reduction	16:1	Start circuit	Low voltage push button or radio control
Drive	Chain & cable with two-piece trolley on steel Tee rail	DIMENSIONS	
Lubrication	Motor is self-lubricated. Drive shaft bronze oil-lite bearings	Length (overall)	121-1/2 inches
Length of Travel	Adjustable to 7-1/2 feet	Headroom required	2 inches
Travel rate	6 to 8 inches per second	Shipping Weight	43 pounds
Lamp	On when door starts in travel, off 4-1/2 minutes after stop. Also separate Work Light push button		
Door linkage	Adjustable door arm Pull cord trolley release		

YOU'LL NEED TOOLS

During assembly and installation of your opener, the instruction will call for use of various hand tools. Have a stepladder handy, and those tools illustrated below: Hammer, electric drill (also 3/16" and 5/16" drill bits), screwdriver, adjustable end wrench or socket wrench kit, wire cutters, tape measure, pliers and hack saw.

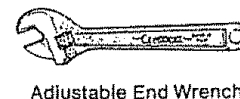
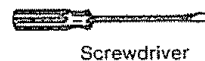
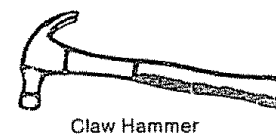
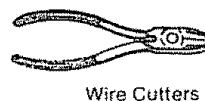
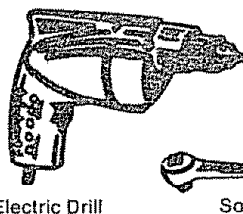
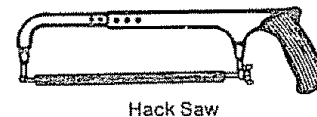
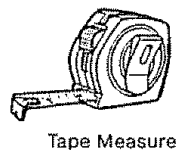
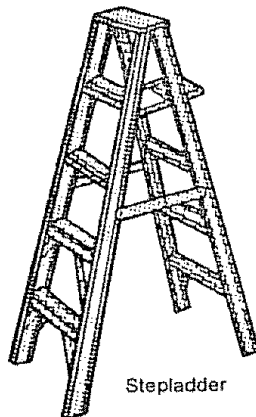

Start By Reading These Important Safety Rules



THIS SAFETY ALERT SYMBOL MEANS CAUTION — PERSONAL SAFETY OR PROPERTY DAMAGE INSTRUCTION. READ THESE INSTRUCTIONS CAREFULLY.

THIS GARAGE DOOR OPENER IS DESIGNED AND TESTED TO OFFER REASONABLY SAFE SERVICE PROVIDED IT IS INSTALLED AND OPERATED IN STRICT ACCORDANCE WITH THE FOLLOWING SAFETY INSTRUCTIONS.

FAILURE TO COMPLY WITH THE FOLLOWING INSTRUCTIONS MAY RESULT IN SERIOUS PERSONAL INJURY OR PROPERTY DAMAGE.



KEEP GARAGE DOOR BALANCED. STICKING OR BINDING DOORS MUST BE REPAIRED. GARAGE DOORS, DOOR SPRINGS, CABLES, PULLEYS, BRACKETS AND THEIR HARDWARE MAY BE UNDER EXTREME TENSION AND CAN CAUSE SERIOUS PERSONAL INJURY. DO NOT ATTEMPT ADJUSTMENTS. CALL A GARAGE DOOR SERVICEMAN TO MOVE, LOOSEN OR ADJUST DOOR SPRINGS OR HARDWARE.



DO NOT USE FORCE ADJUSTMENTS TO COMPENSATE FOR A BINDING OR STICKING GARAGE DOOR. EXCESSIVE FORCE WILL INTERFERE WITH THE PROPER OPERATION OF THE SAFETY REVERSE SYSTEM OR DAMAGE THE GARAGE DOOR. (SEE PAGE 19).



DO NOT WEAR RINGS, WATCHES OR LOOSE CLOTHING WHILE INSTALLING OR SERVICING A GARAGE DOOR OPENER.



FASTEN THE CAUTION LABEL ON THE WALL NEAR THE WALL CONTROL AS A REMINDER OF SAFE OPERATING PROCEDURES.



TO AVOID SERIOUS PERSONAL INJURY FROM ENTANGLEMENT, REMOVE ALL ROPES CONNECTED TO THE GARAGE DOOR BEFORE INSTALLING THE GARAGE DOOR OPENER.



INSTALL THE WALL CONTROL (OR ADDITIONAL PUSH BUTTONS) OUT OF THE REACH OF CHILDREN. DO NOT ALLOW CHILDREN TO OPERATE WALL CONTROL OR TRANSMITTER. SERIOUS PERSONAL INJURY FROM A CLOSING GARAGE DOOR MAY RESULT FROM ANY MISUSE OF THE OPENER.



DISENGAGE ALL EXISTING GARAGE DOOR LOCKS TO AVOID DAMAGE TO GARAGE DOOR.



INSTALLATION AND WIRING MUST BE IN COMPLIANCE WITH LOCAL BUILDING AND ELECTRICAL CODES.



CAUTION: ACTIVATE OPENER ONLY WHEN THE DOOR IS IN FULL VIEW, FREE OF OBSTRUCTION AND OPENER IS PROPERLY ADJUSTED. NO ONE SHOULD ENTER OR LEAVE THE GARAGE WHILE DOOR IS IN MOTION. DO NOT ALLOW CHILDREN TO PLAY NEAR DOOR.



LIGHTWEIGHT DOORS REQUIRE SUBSTANTIAL REINFORCEMENT TO AVOID DOOR DAMAGE. (SEE PAGE 10).



USE EMERGENCY RELEASE ONLY TO DISENGAGE TROLLEY. DO NOT USE RED EMERGENCY RELEASE ROPE AND HANDLE TO PULL DOOR OPEN OR CLOSED.



THE SAFETY REVERSE SYSTEM TEST IS IMPORTANT (SEE PAGE 20). THE GARAGE DOOR *MUST* REVERSE ON CONTACT WITH A ONE-INCH OBSTACLE PLACED ON THE FLOOR. FAILURE TO PROPERLY ADJUST THE OPENER MAY RESULT IN SERIOUS PERSONAL INJURY FROM A CLOSING GARAGE DOOR. REPEAT THE TEST AT LEAST ONCE A YEAR AND MAKE ANY NEEDED ADJUSTMENTS.



DISCONNECT ELECTRIC POWER TO GARAGE DOOR OPENER BEFORE MAKING REPAIRS OR REMOVING COVERS.

CARTON CHECK LIST

SEARS has packaged your Garage Door Opener in two cartons. **THE RAIL ASSEMBLY CARTON CONTAINS:** a three-piece rail, two hanging straps, straight door arm section* and rail assembly hardware.

THE OPENER CARTON CONTAINS:

Opener Chassis

Plastic Light Lenses (2)

3-Channel Transmitter and Clip (2)

Chain & Cable (in dispenser carton)*

2-Piece Trolley*

*ILLUSTRATED BELOW

Wall Control

Sprocket Cover*

Cable Pully Bracket*

Door Bracket & Plate*

Wedge Door Arm Section*

Header Bracket*

4-Strand Bell Wire*

Owners Manual

Hardware Bag

(Includes Caution Label)

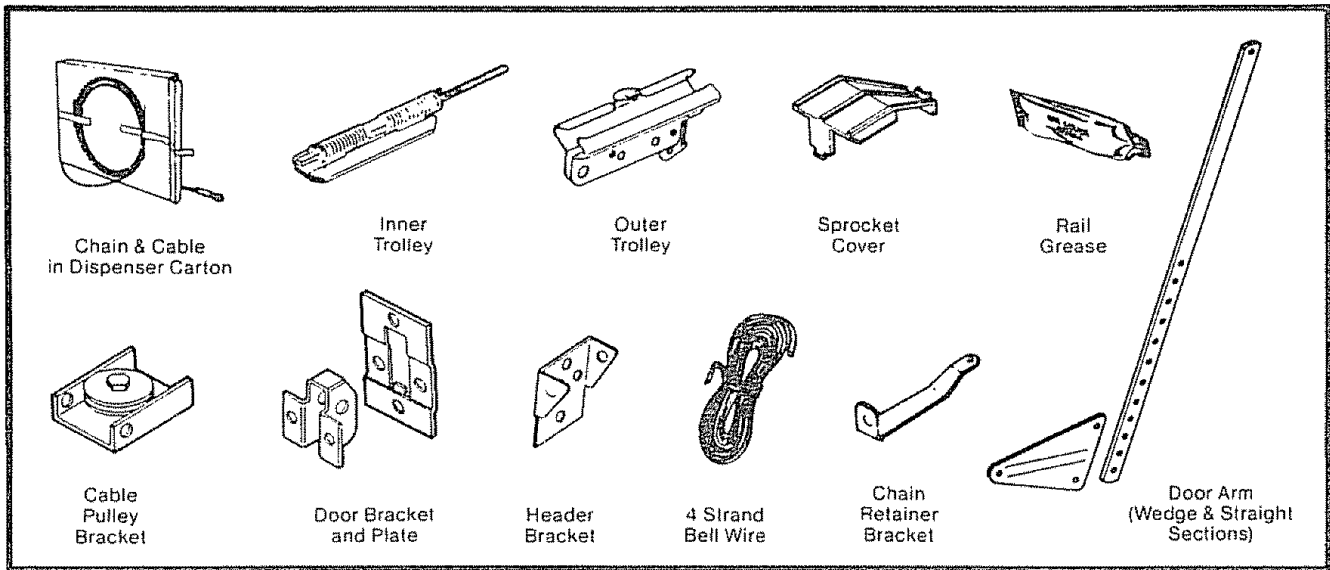

SEPARATE ALL HARDWARE FOR ASSEMBLY AND INSTALLATION PROCEDURES AS SHOWN BELOW.

ASSEMBLY HARDWARE

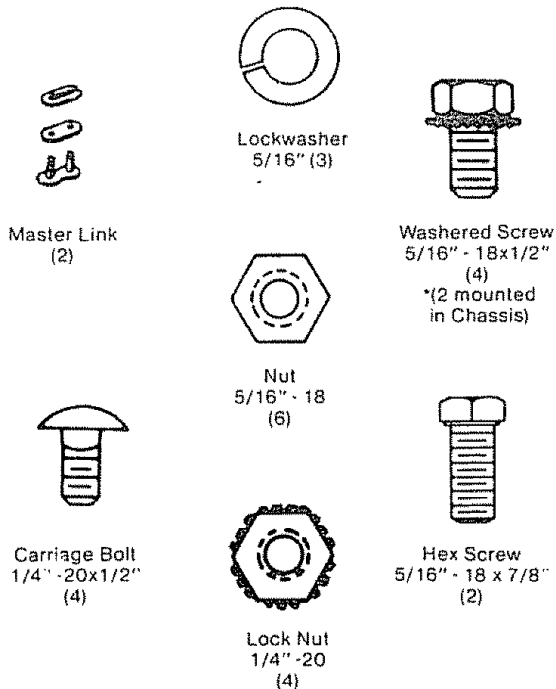

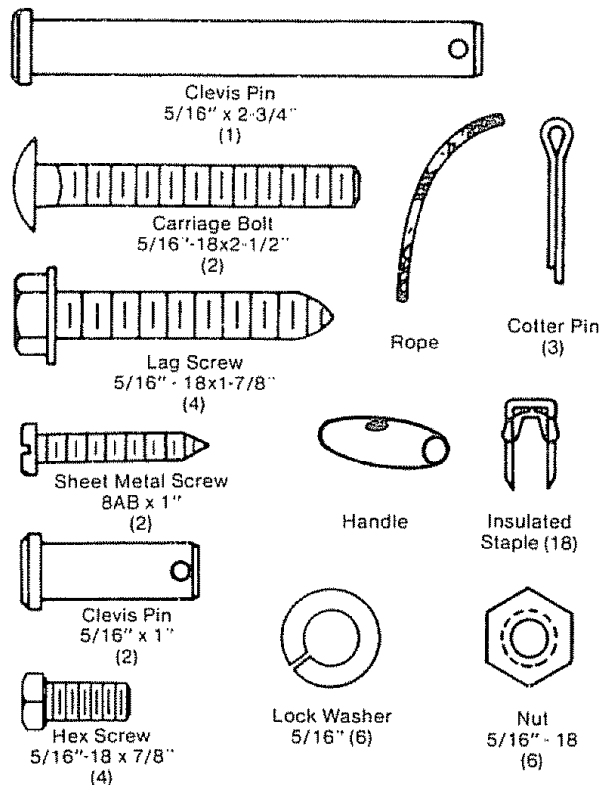

INSTALLATION HARDWARE

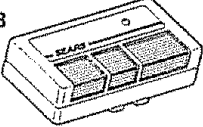
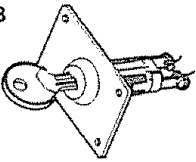
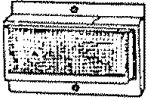

Accessories

Sears offers many useful accessories for your garage door opener. They are illustrated below with Sears stock numbers and descriptions.

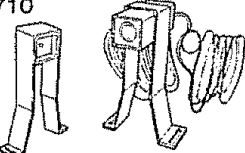
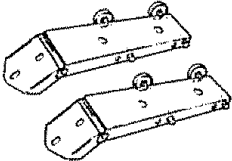
<p>53718</p> 	<p>EXTRA TRANSMITTER: Includes visor clip.</p>
<p>53703</p> 	<p>OUTDOOR KEY SWITCH: Opens the garage door automatically from outside when transmitter is not handy.</p>
<p>53701</p> 	<p>OPEN DOOR INDICATOR: Provides an illuminated signal when your garage door is open.</p>
<p>53702</p> 	<p>QUICK RELEASE KEY LOCK: Allows manual operation of your garage door from the outside in case of power failure or where there is no service entrance. For wood or metal doors only.</p>
<p>53710</p> 	<p>INFRARED REVERSING SENSOR: An optional system which provides auxiliary support to the safety features built into your opener. Sensors detect any obstruction to your door while in the down cycle and transmit a signal to the opener. The opener will cause a closing door to reverse and prevent an open door from closing.</p>
<p>53709</p> 	<p style="text-align: center;">FOR SECTIONAL DOORS ONLY</p> <p>QUICK TURN BRACKETS: Replace top brackets and rollers on door to reduce height of door travel. For use when installing opener in garage with low head-room clearance.</p>

IDENTIFY YOUR DOOR TYPE FROM THESE ILLUSTRATIONS

**SECTIONAL DOOR
CURVED TRACK**

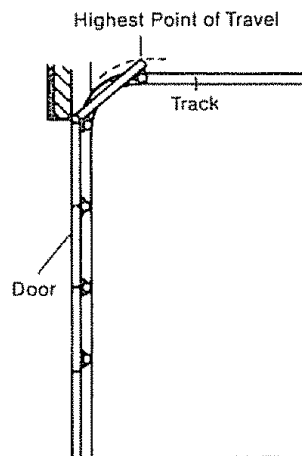

**ONE PIECE DOOR
NO TRACK
JAMB HARDWARE**

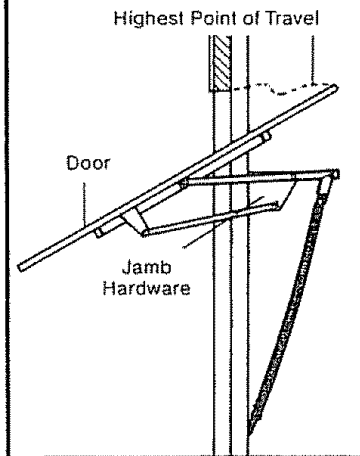

**ONE PIECE DOOR
HORIZONTAL TRACK
JAMB HARDWARE**

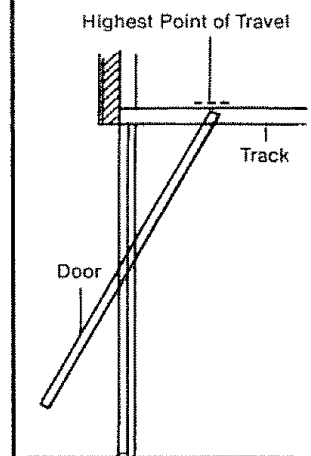

**ONE PIECE DOOR
NO TRACK
PIVOT HARDWARE**

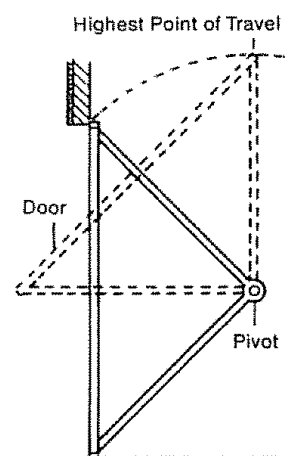

CERTAIN INSTALLATION PROCEDURES VARY ACCORDING TO GARAGE DOOR TYPES. WHERE DIFFERENCES OCCUR, BE SURE TO FOLLOW ONLY THOSE INSTRUCTIONS WHICH APPLY TO YOUR DOOR CONSTRUCTION.

Assembly

TO AVOID INSTALLATION DIFFICULTIES, DO NOT RUN THE GARAGE DOOR OPENER UNTIL YOU HAVE COMPLETED STEP 8, PAGE 15.

STEP 1

Assemble Tee Rail & Attach Cable Pulley Bracket

CAUTION: Do not tighten the lock nuts until bolt necks are seated in square holes.

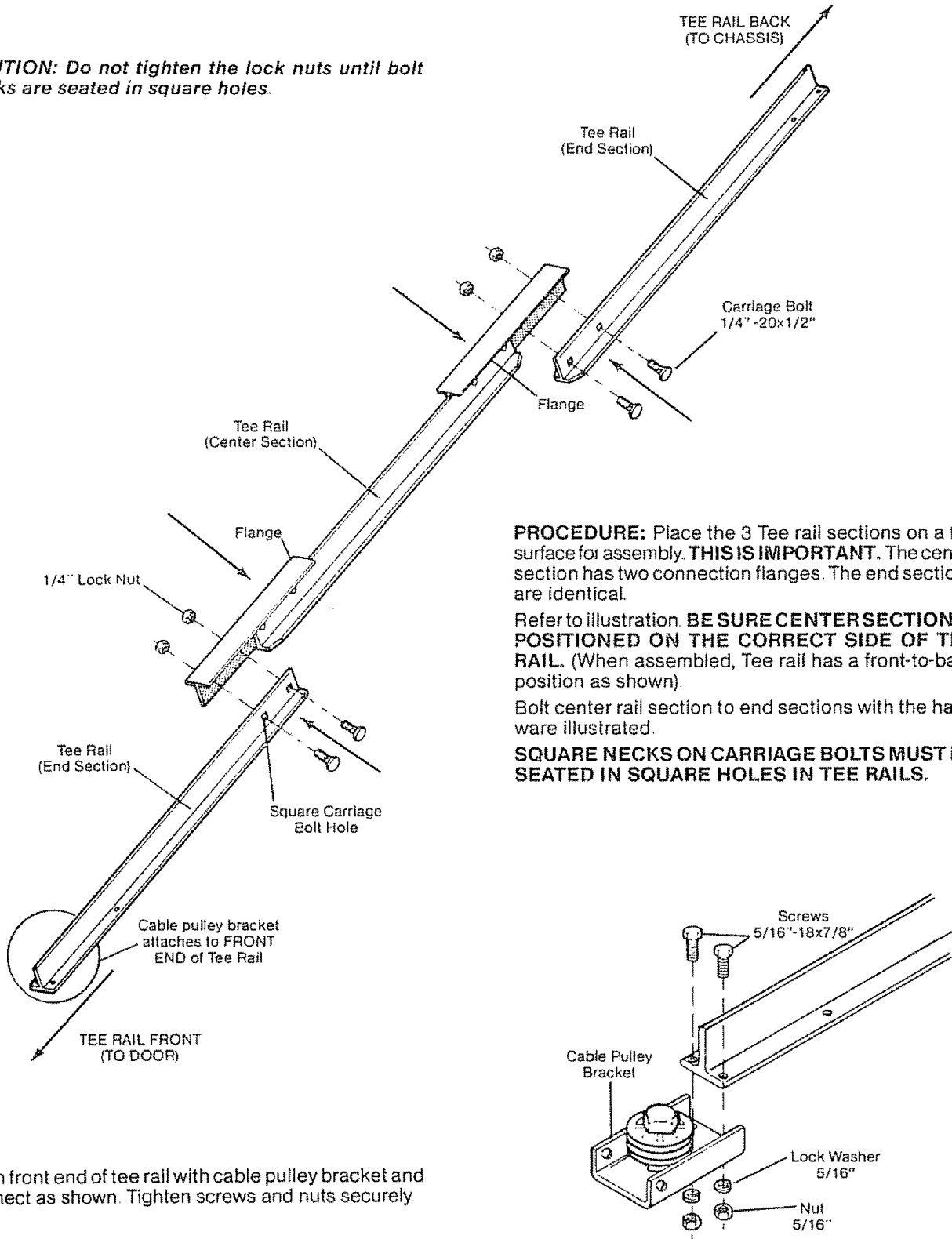

Assembly

STEP 2 *Connect Trolley & Attach Chain Retainer Bracket*

As a temporary stop, insert a screwdriver into Tee rail as shown. Slide the inner trolley onto the Tee rail, as shown, until it is firmly against the screwdriver. Slide the outer trolley onto the Tee rail until it partially engages the inner trolley and stops

TO FULLY ENGAGE TROLLEY: With a hammer, firmly tap the back end of outer trolley just below the rail guide. Outer trolley must move forward to fully engage inner trolley. Be careful to avoid damaging trolley spring.

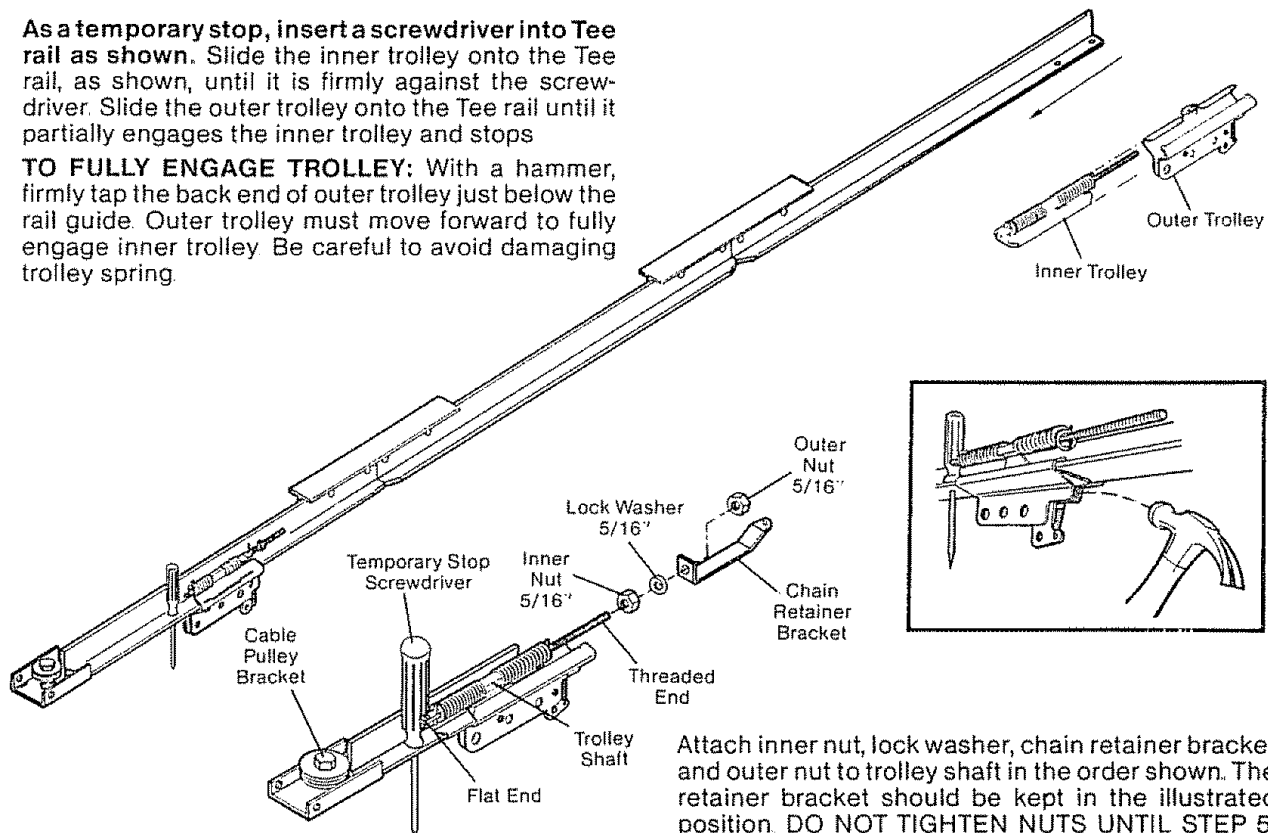

Attach inner nut, lock washer, chain retainer bracket and outer nut to trolley shaft in the order shown. The retainer bracket should be kept in the illustrated position. **DO NOT TIGHTEN NUTS UNTIL STEP 5, PAGE 9**

STEP 3 *Attach Tee Rail to Opener Chassis*



USE ONLY THOSE SCREWS MOUNTED IN TOP OF OPENER CHASSIS. FAILURE TO DO SO WILL CAUSE SERIOUS DAMAGE TO THE DOOR OPENER.

PROCEDURE: Place opener chassis on packing material to protect cover. For convenience, place a support under the cable pulley bracket.

Remove 5/16"-18x1/2" washered screws mounted in top of opener chassis. Align holes in back end of Tee rail with holes in opener chassis. **Fasten the rail to the chassis with washered screws previously removed. CAUTION: USE ONLY THESE SCREWS!** Use of any other screws will cause serious damage to door opener. Tighten screws securely.

Insert a 5/16"-18x1/2" washered screw into the permanent stop hole in the Tee rail back section as shown. Tighten securely with a 5/16" nut.

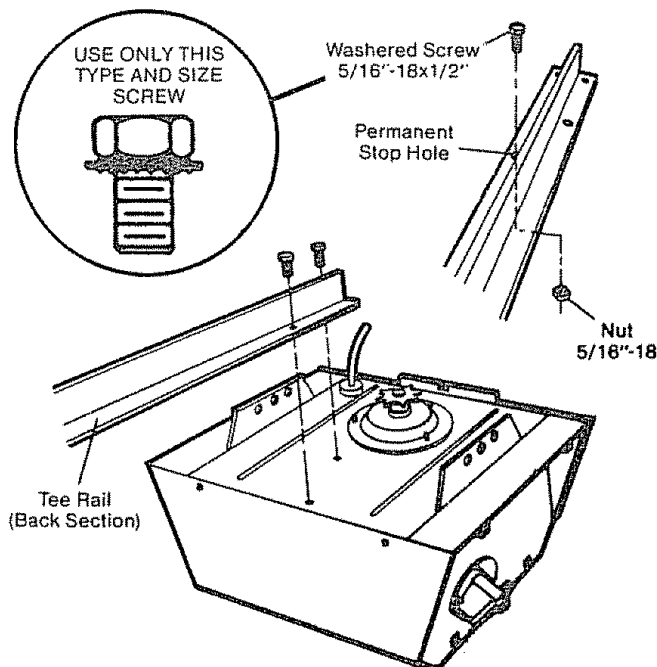

Assembly

STEP 4 Install Chain and Cable

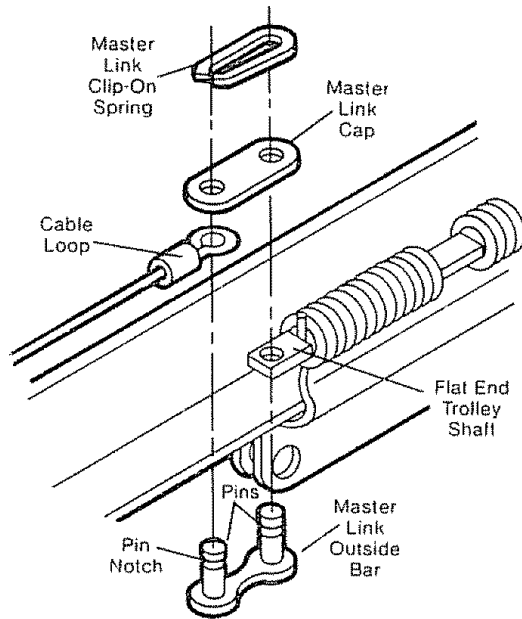

DO NOT REMOVE CHAIN AND CABLE FROM DISPENSER CARTON.

Detach cable from side of carton and fasten to trolley with a master link from coin envelope.

MASTER LINK PROCEDURE: Push pins of master link bar through loop of cable and hole in flat end of trolley shaft. Push cap onto pins and into notches. Slide clip-on spring over cap and into pin notches until both pins are locked in place.

CAUTION: Keep chain taut while dispensing from carton to help prevent kinking.

Slide trolley tight against screwdriver stop. Dispense cable around pulley bracket. Proceed back around the opener sprocket and forward to chain retainer bracket. Be sure teeth on chassis sprocket engage chain.

Connect chain to chain retainer bracket, as shown in inset, using second master link from coin envelope.

NOTE: Check to make sure chain is not twisted.

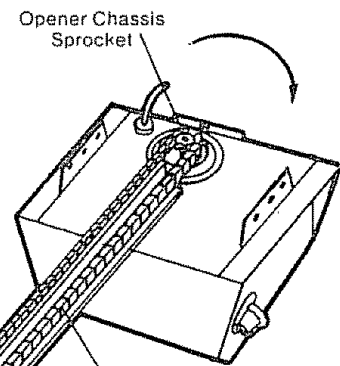

Install Chain and Cable in This Direction

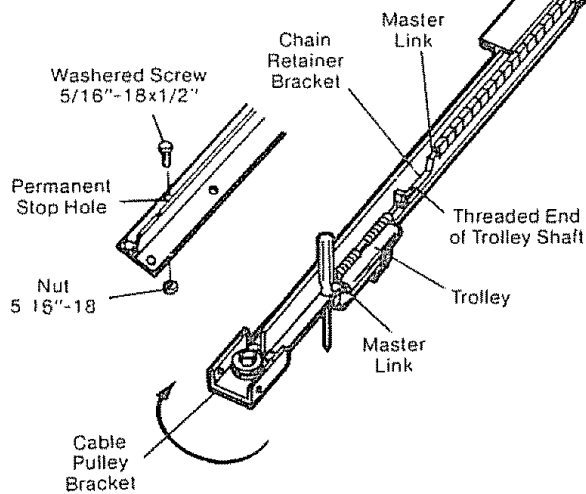

As a permanent trolley stop, insert 5/16" washered screw into remaining hole in Tee rail front. Tighten securely with 5/16" nut. **REMOVE TEMPORARY STOP INSERTED IN STEP 2.**

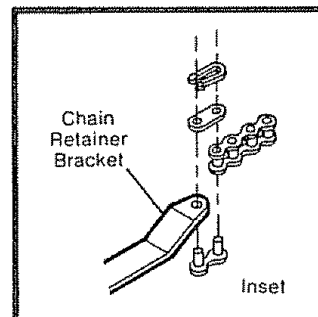

Assembly

STEP 5

Tighten the Chain and Cable

CAUTION: Keep chain from twisting as nuts are turned.

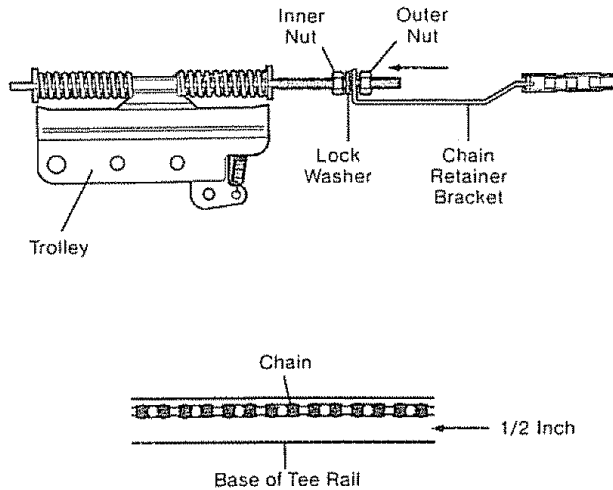

PROCEDURE: Thread inner nut along shaft toward trolley. Tighten chain and cable by turning outer nut in the same direction as shown.

Chain is properly tightened when it is approximately 1/2" above the base of Tee rail midway between cable pulley bracket and chassis.

When chain tension is correct, turn inner nut toward chain retainer bracket until tight. **If chain begins to sag below Tee rail after repeated door opener operations:**

1. Loosen inner nut (thread toward trolley).
2. Tighten outer nut (thread toward trolley).
3. Retighten inner nut (thread toward chain retainer bracket).

STEP 6

Attach Sprocket Cover to Opener Chassis

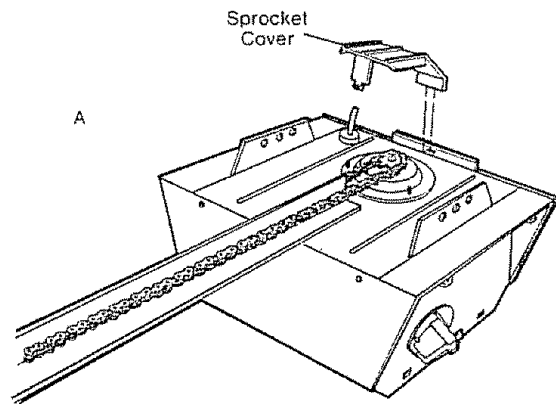

PROCEDURE: Attach sprocket cover to chassis as shown in Illustrations (A) and (B). Insert back tab in chassis slot. Then bend cover forward and insert front tab in slot provided on mounting plate.

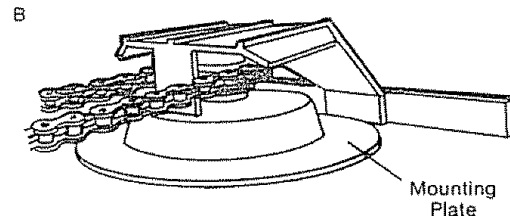

ASSEMBLY OF YOUR GARAGE DOOR OPENER IS NOW COMPLETE.

CERTAIN INSTALLATION PROCEDURES VARY ACCORDING TO GARAGE DOOR TYPES. WHERE DIFFERENCES OCCUR, BE SURE TO FOLLOW ONLY THOSE INSTRUCTIONS WHICH APPLY TO YOUR DOOR CONSTRUCTION.



DO NOT WEAR WATCHES, RINGS OR LOOSE CLOTHING WHILE INSTALLING OR SERVICING A DOOR OPENER.



KEEP GARAGE DOOR BALANCED. STICKING OR BINDING DOORS MUST BE REPAIRED. GARAGE DOORS, DOOR SPRINGS, CABLES, PULLEYS, BRACKETS AND THEIR HARDWARE MAY BE UNDER EXTREME TENSION AND CAN CAUSE SERIOUS PERSONAL INJURY. DO NOT ATTEMPT ADJUSTMENTS. CALL A GARAGE DOOR SERVICEMAN TO MOVE, LOOSEN OR ADJUST DOOR SPRINGS OR HARDWARE.

Installation

Completed installations of header bracket, door bracket and door arm (depending on door type) are shown below. The header bracket supports the front end of the Tee rail. The door bracket connects door arm to trolley

IT IS RECOMMENDED THAT THE OPENER BE INSTALLED 7 FEET OR MORE ABOVE THE FLOOR WHERE SPACE PERMITS *Follow only those instructions which apply to your door type as shown on Page 5.*

STEP 1 Install Door Bracket and Plate



TO PREVENT DAMAGE TO LIGHTWEIGHT GARAGE DOORS, ALWAYS REINFORCE THE INSIDE OF DOOR— BOTH VERTICALLY AND HORIZONTALLY—WITH 2x4 BOARDS OR ANGLE IRON.

Horizontal brace should be at least 6 feet long. Vertical brace should cover height of top panel. Reinforcement hardware is not supplied (See No. 1 Below) FASTEN SECURELY AS SHOWN BEFORE INSTALLING DOOR BRACKET AND PLATE.

Sectional Door Installation Procedure

With door closed, locate and mark the vertical center-line of garage door. Extend line onto header wall above door.

1. Assemble door bracket and plate as shown. Center bracket on vertical guideline (or up to one foot left or right of center if necessary)

2. Position bracket assembly on face of door within the following limits: A. Top edge of bracket 2" to 4" below the top edge of door. B. Directly below any structural support across top of door. Placement depends on your particular needs

3. Mark and drill 5/16" TOP and BOTTOM fastening holes. Secure bracket as shown.

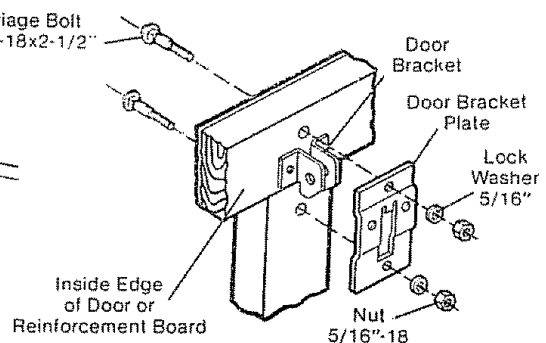
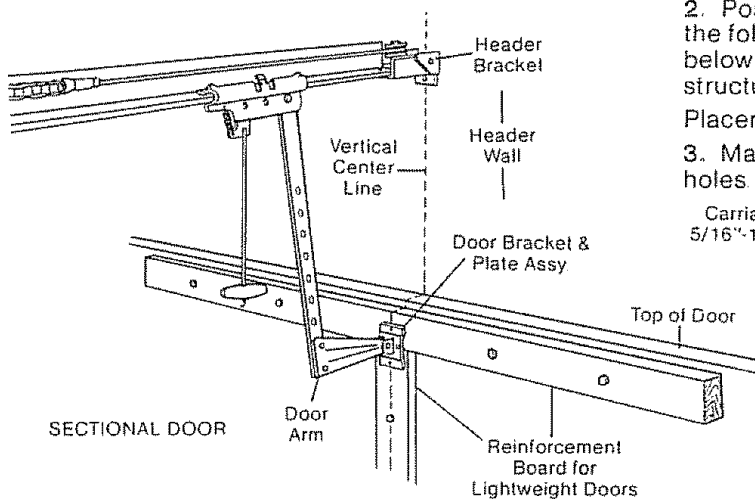

All One-Piece Door Installation Procedure

With door closed, locate and mark vertical centerline of door. Extend line onto header wall above door.

NOTE: The door bracket has left and right side fastening holes. Assemble door bracket and plate if your installation requires top and bottom fastening holes. (Refer to illustration).

Center bracket (with or without plate as required) on top edge of door as shown. Mark and drill two 5/16" fastening holes and secure door bracket. **NOTE:** If door has no exposed framing, drill 3/16" pilot holes and substitute 5/16" x 1-1/2" lag screws (not supplied) to fasten bracket to top of door.

NOTE: Door bracket may be installed on face of door if required for your installation. (Refer to dotted line drawing). **HOWEVER,** drill 3/16" pilot holes and substitute 5/16" x 1-1/2" lag screws (not supplied) to fasten bracket to door.

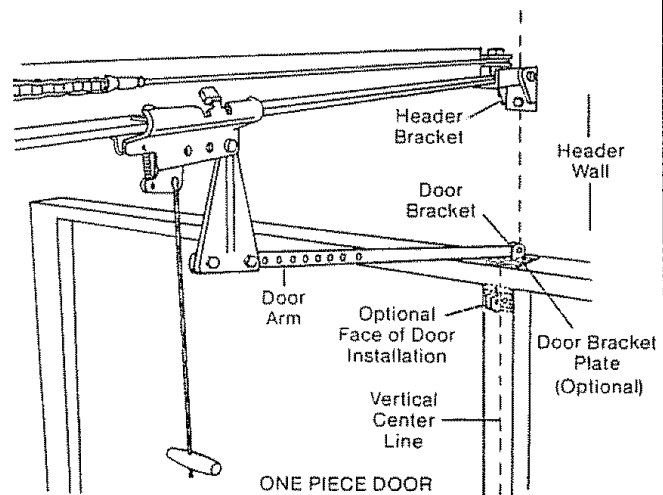
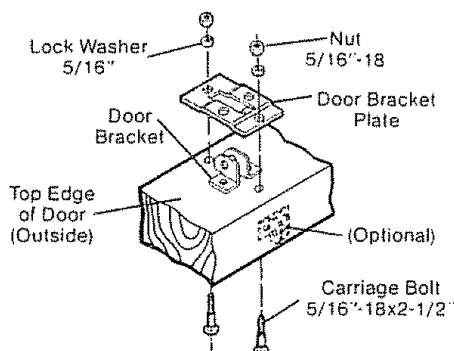

Installation

STEP 2 Position & Install Header Bracket



THE HEADER BRACKET MUST BE RIGIDLY FASTENED TO THE HEADER WALL OR CEILING. REINFORCE WALL OR CEILING WITH 2x4 IF NECESSARY.

Locate height for header bracket by opening door to highest point of travel as shown. Draw a horizontal line on header wall 2" above high point. This height provides travel clearance for top edge of door.

When headroom is not sufficient for 2" clearance, bottom edge of bracket may be placed parallel to the high point of travel, or bracket may be attached to ceiling.

Optional Quick Turn Brackets are designed for low headroom installations. They replace top brackets and rollers on the garage door, thereby lowering the high point of door travel. Installation instructions are contained in the accessory carton.

Position bracket as shown (bottom edge of bracket on horizontal line). Mark either top and bottom or left and right bracket holes. Drill 3/16" pilot holes and fasten bracket.

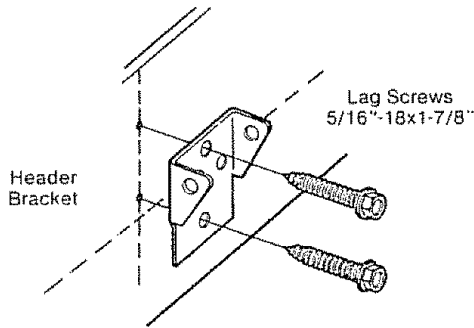

INSTALLATION SECTIONAL DOOR AND 1-PIECE DOOR WITH TRACK

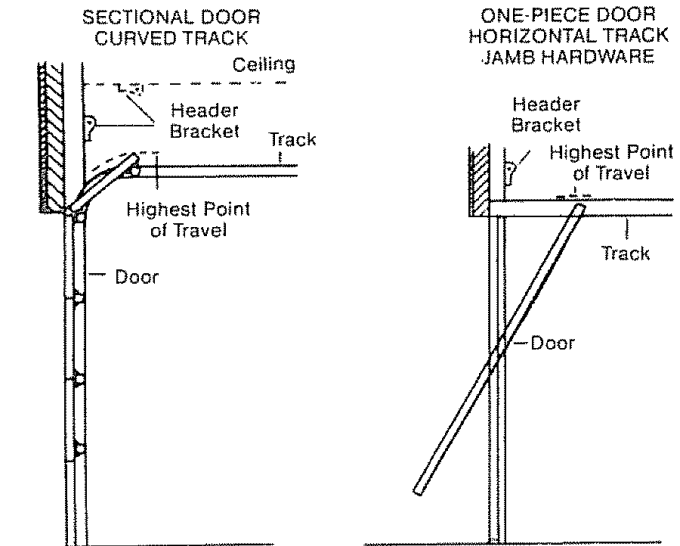

INSTALLATION 1-PIECE DOOR WITHOUT TRACK

ONE-PIECE DOOR
NO TRACK
PIVOT HARDWARE

ONE-PIECE DOOR
NO TRACK
JAMB HARDWARE

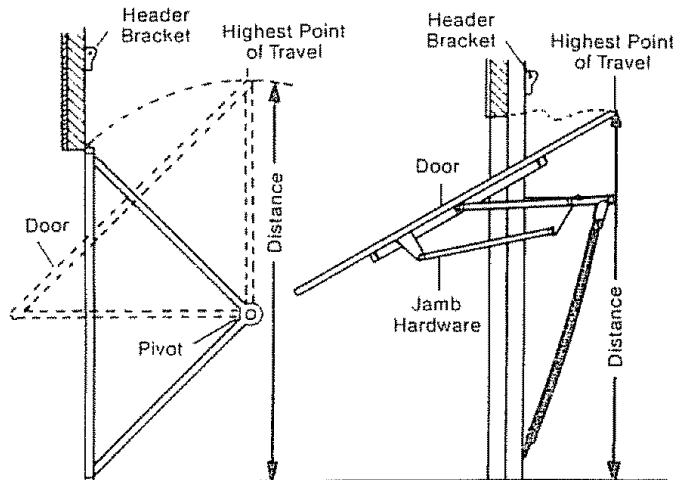

Locate height for header bracket by opening door to highest point of travel as shown. Measure distance from top of door to floor. Subtract actual height of door. Add 8" to the remainder. See example below.

If the total number of inches exceeds the height available in your garage, use the maximum height possible. On finished ceilings, do not position the bracket closer than 1/2" from ceiling.

Measuring from top of door, draw a horizontal line on the header wall at the determined height. Position bottom edge of header bracket on horizontal line, centering bracket on vertical line. Mark either top and bottom or left and right holes. Drill 3/16" pilot holes and fasten with 5/16" x 1-7/8" lag screws as shown above.

EXAMPLE

Distance from top of door (at highest point of travel) to floor	92"
Actual height of door	-88"
Remainder	4"
Add	+ 8"
Bracket height on header wall	=12"

Installation

STEP 3

Attach Tee Rail to Header Bracket

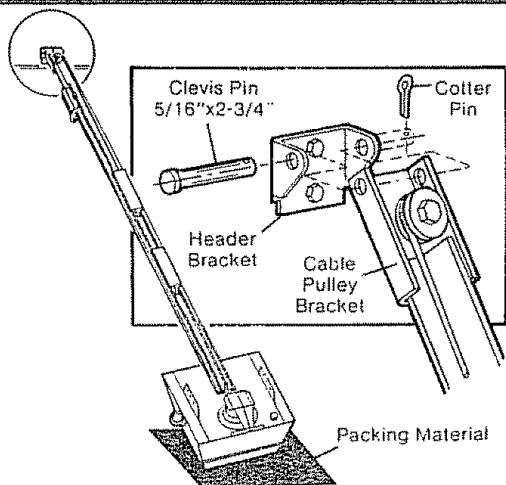

PROCEDURE: Position opener chassis on garage floor below door and header brackets. Use packing material base to protect cover. **NOTE:** To enable Tee rail to clear sectional door springs, it may be necessary to lift the chassis onto a temporary support.

CAUTION: Chassis must either be secured to support or held firmly in place by another person.

Raise Tee rail until cable pulley and header brackets come together. Align bracket holes and join with clevis pin as shown. Insert and spread cotter pin to secure.

STEP 4

Position Opener Chassis



TO PREVENT DAMAGE TO ALL LIGHTWEIGHT DOORS, AND DOORS WITH WINDOWS, DO NOT REST THE OPENER ON THE DOOR.

SECTIONAL and ONE-PIECE DOOR WITH TRACK INSTALLATION

NOTE: A 2x4 is convenient for setting an ideal door-to-Tee rail distance. It is not necessary where headroom is insufficient.

PROCEDURE: Raise the opener chassis onto a stepladder. Open the garage door. Place a 2x4 on edge on top section of door directly above door bracket. Rest Tee rail on 2x4.

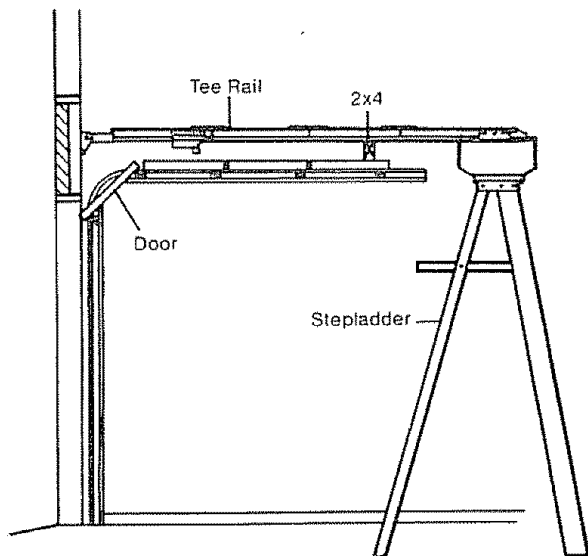

ONE-PIECE DOOR WITH NO - TRACK INSTALLATION

PROCEDURE: Measure the distance from floor to top of door (in fully open position and parallel to floor).

Using a stepladder as a support, raise the opener chassis to the same distance from the floor (chassis will have a slight angle as shown).

The top of the door should be level with the top of the opener. For maximum efficiency, do not position the opener chassis more than 2 inches above this point.

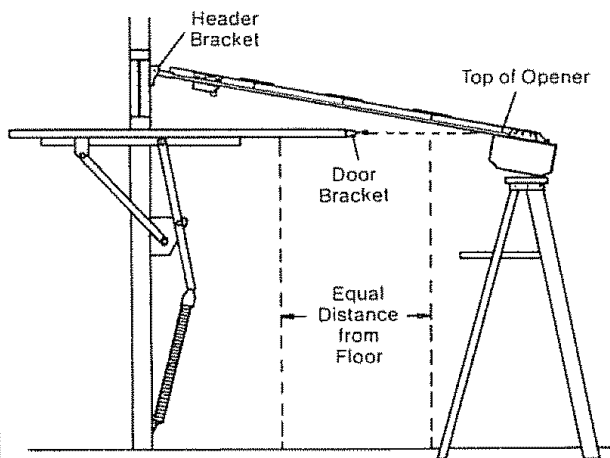

Installation

STEP 5 Hang Opener Chassis

THE OPENER CHASSIS MUST BE ATTACHED TO A STRUCTURAL SUPPORT OF THE GARAGE. Three representative installations are shown. Yours may be different. Hanging brackets should be angled to provide rigid support.

PROCEDURE: On EACH side of opener measure the distance from chassis to structural support.

Cut both pieces of the hanging bracket to required lengths. Flatten one end of each bracket and bend or twist to fit fastening angles. **DO NOT BEND AT BRACKET HOLES.** Drill $\frac{3}{16}$ " pilot holes in structural support. Fasten flattened ends of brackets to support as shown.

Lift opener and fasten to hanging bracket as shown. **Check to make sure Tee rail is centered over door bracket.** Close the garage door. If door hits rail, raise header bracket. **REMOVE 2x4.**

Grease rail surfaces on which trolley slides. A tube of grease is supplied

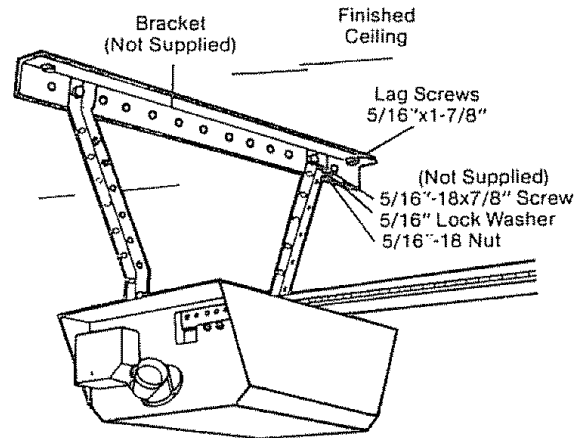
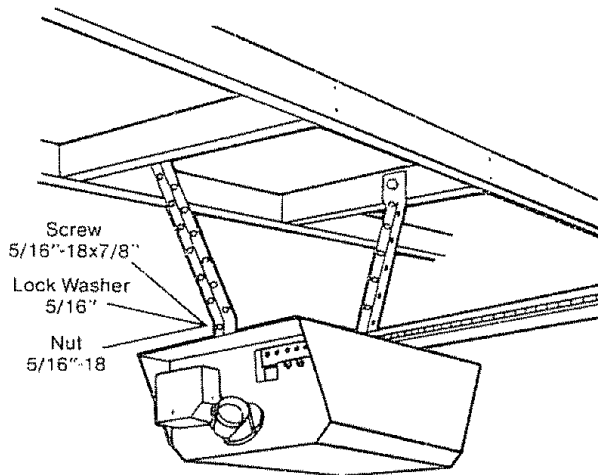
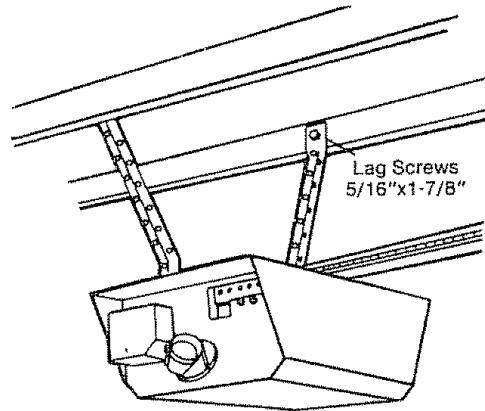

STEP 6 Attach Emergency Release Rope & Handle



USE EMERGENCY RELEASE ONLY TO DIS-ENGAGE TROLLEY. DO NOT USE RED EMERGENCY RELEASE ROPE AND HANDLE TO PULL DOOR OPEN OR CLOSED.

PROCEDURE: Thread one end of rope through hole in red handle and secure with an overhand knot. **NOTE: Knot should be at least 1 inch from end of rope to prevent slipping.** Thread other end of rope through hole in release arm of outer trolley. Adjust rope length so that handle is 6 feet above the floor. Secure with an overhand knot as above.

NOTE: If it is necessary to cut rope, heat seal cut end with a match or lighter to prevent fraying and/or raveling.

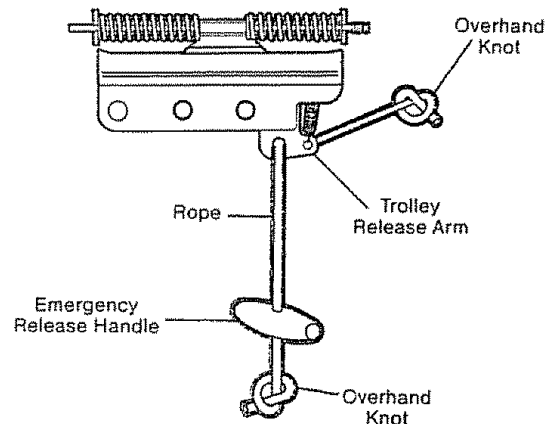

Installation

STEP 7 *Install Wall Control*

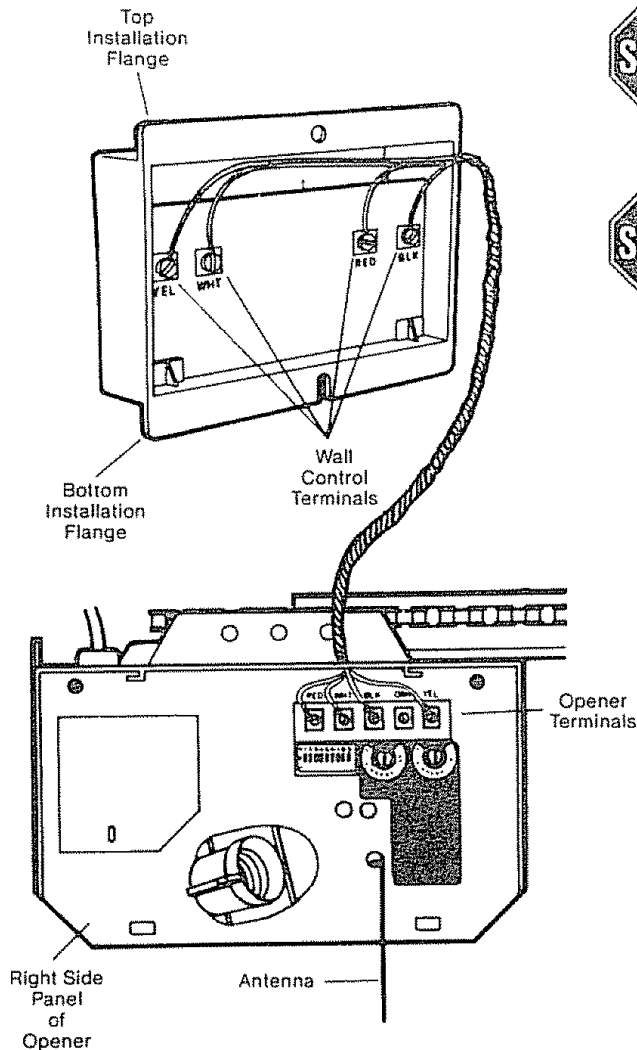

INSTALL WALL CONTROL (OR ADDITIONAL PUSH BUTTONS) OUT OF THE REACH OF CHILDREN. DO NOT ALLOW CHILDREN TO OPERATE WALL CONTROL OR TRANSMITTER. SERIOUS PERSONAL INJURY FROM A CLOSING GARAGE DOOR MAY RESULT FROM ANY MISUSE OF OPENER.



FASTEN THE CAUTION LABEL ON THE WALL NEAR THE WALL CONTROL AS A REMINDER OF SAFE OPERATING PROCEDURES.

PROCEDURE: There are 4 screw terminals on the back of the Wall Control. Connect the bell wire by color; yellow to yellow, white to white, red to red and black to black.

Fasten Wall Control to an inside garage wall, as shown, with the 8ABx1" sheet metal screws provided. A convenient place is beside the service door and OUT OF THE REACH OF CHILDREN.

Run the bell wire up the wall and across the ceiling to the garage door opener. Use insulated staples.

The receiver terminals as well as the antenna are located on the right side panel of the opener. Bend antenna wire down until it is parallel to chassis panel. Then connect the wire by color to the red, white, black and yellow opener terminal screws.

WIRING INSTRUCTIONS FOR ACCESSORIES

Infrared Reversing System:

To white & black opener terminals

Open Door Indicator:

To white & orange opener terminals

Key Switch:

To red & white opener terminals

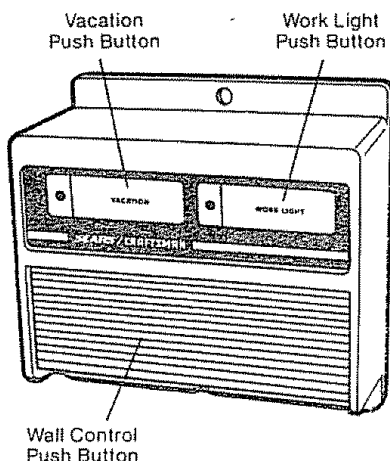

OPERATION OF WALL CONTROL

WALL CONTROL PUSH BUTTON

Press and release to open or close door

Press and release again to REVERSE door during CLOSING cycle or to STOP door during OPENING cycle

VACATION PUSH BUTTON

Activate Vacation feature only when door is in closed position.

Press and release Push button light will turn ON. The Vacation feature was designed to prevent operation of door from the transmitter and allow door to travel in the UP direction ONLY from the Wall Control push button (press and release) and Key Switch accessory.

Press and release again Push button light will turn OFF. Opener will return to normal operation.

A power failure of more than 30 seconds will cause the vacation feature to turn OFF.

WORK LIGHT PUSH BUTTON

Press and release Opener light will turn on and remain on.

Press and release again Opener light will return to normal operation and turn off after 4-1/2 minutes.

Installation

STEP 8 *Connect Electric Power*



TO AVOID SERIOUS PERSONAL INJURY FROM ENTANGLEMENT, REMOVE ALL ROPES CONNECTED TO THE GARAGE DOOR BEFORE OPERATING DOOR OPENER.

REMOVE EXISTING GARAGE DOOR LOCKS OR USE A WOOD SCREW OR NAIL TO MAKE THEM INOPERATIVE. INSTALLATION AND WIRING MUST BE IN COMPLIANCE WITH LOCAL BUILDING AND ELECTRICAL CODES. OPERATION AT OTHER THAN 120V 60Hz WILL CAUSE OPENER MALFUNCTION AND DAMAGE.

IF LOCAL ELECTRICAL CODES DO NOT REQUIRE PERMANENT WIRING: Insert the 3-prong plug into a 3-hole receptacle. UNIT MUST BE GROUNDED. DO NOT USE A 2-WIRE ADAPTER.

IF LOCAL CODES REQUIRE PERMANENT WIRING: Refer to illustration.

PROCEDURE: Make connection through 7/8 inch diameter hole in top of opener chassis.

1. Remove opener chassis cover by removing the 4 cover screws.
2. Remove attached 3-prong cord.
3. Connect black (line) wire to black wire on terminal block; white (neutral) wire to white terminal wire; green (ground) wire to green ground screw.

CAUTION: BE SURE UNIT IS GROUNDED ACCORDING TO LOCAL CODE

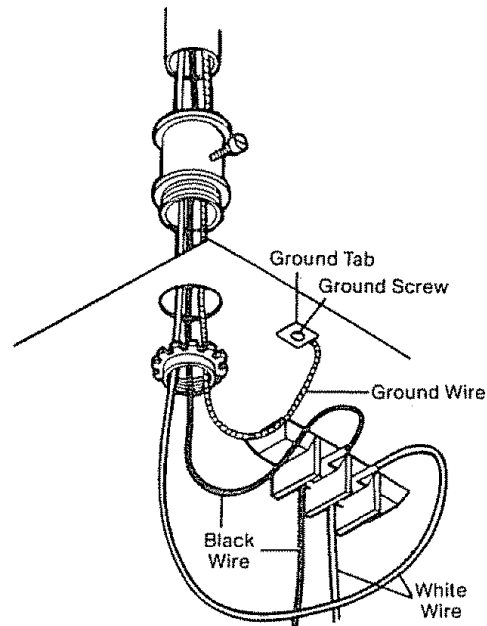

STEP 9 *Install Lights and Lenses*

PROCEDURE: Install a 75 watt maximum light bulb in each socket as shown. The lights turn on automatically when opener starts. After 4-1/2 minutes they will turn off. Lights will REMAIN ON when Work Light push button on Wall Control is pressed.

IMPORTANT NOTE: If the lights in your garage door opener do not work, it may NOT be the fault of the opener. Some short-neck bulbs, because of their shape, do not make contact with the socket base tab. Use standard-neck bulbs.

INSTALLING LENSES: Slide lenses into the lens guides as shown. Snap bottom tabs into lens slots. (The force and limit adjustment settings are located on side panels behind lenses).

NOTE: FOR CONVENIENCE, LENSES MAY BE INSTALLED AFTER ADJUSTMENT, STEP 3, PAGE 20.

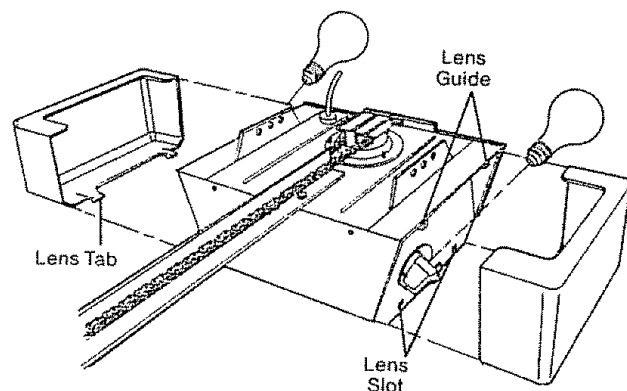

Installation

STEP 10

Connect Door Arm to Trolley

SECTIONAL DOOR INSTALLATION ONLY

PROCEDURE: Fasten straight door arm section to trolley and wedge door arm section to door bracket, as shown (A). Insert and spread a cotter pin to secure each connection.

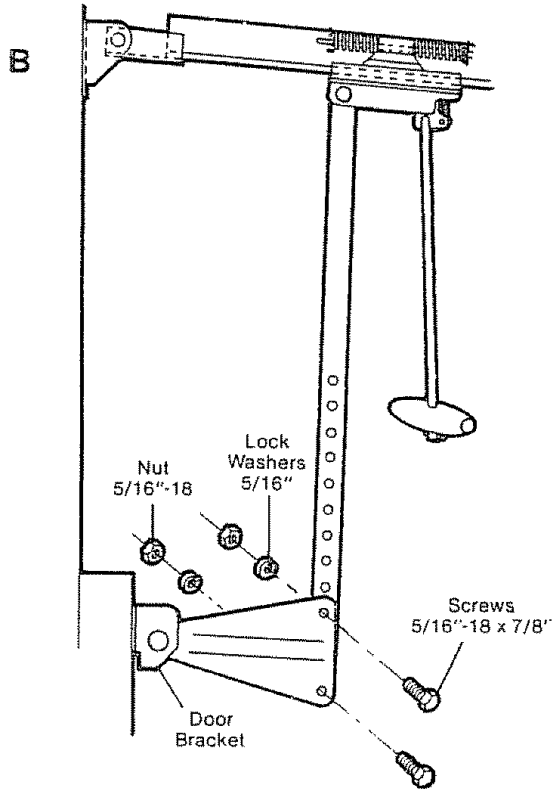
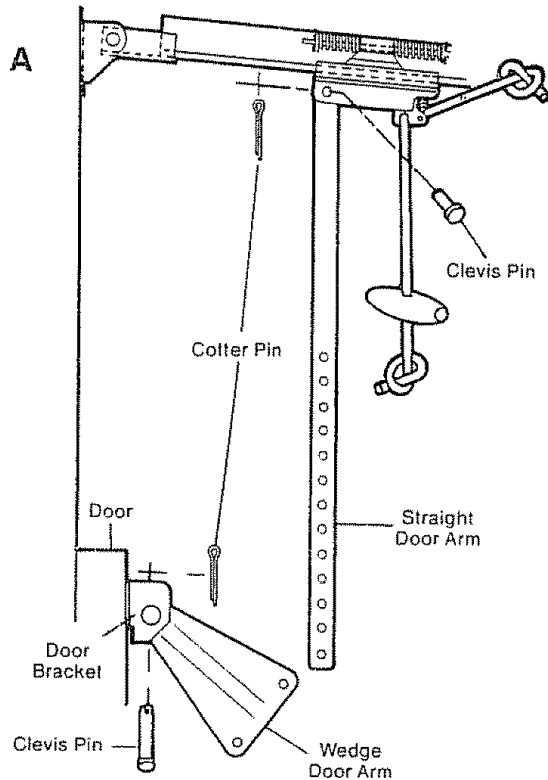

Bring the door arm sections together. Find a pair of holes that line up and join sections as shown (B).

INSTALLATION FOR SECTIONAL DOOR IS COMPLETE. PROCEED TO ADJUSTMENT STEP 1, PAGE 18.

ALL ONE-PIECE DOOR INSTALLATIONS

ASSEMBLE DOOR ARM PROCEDURE: Fasten straight and wedge door arm sections together to their longest possible length. With door closed, connect straight door arm section to door bracket as shown. Insert and spread cotter pin to secure.

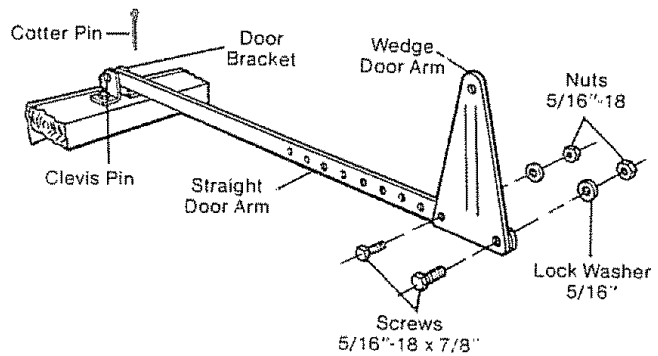

Installation

STEP 11

Adjust Limits (All One-Piece Doors Only)

CAUTION: To prevent damage to garage doors, the opener limits must be adjusted on ALL ONE-PIECE DOORS.

Limit Adjustment settings regulate the points at which door will stop when moving up or down.

Repeated operation of the opener during adjustment may cause the motor to overheat and shut off. Simply wait 15 minutes and continue adjustments.

Limit adjustment screws are located on the left side panel of the opener as shown. Increase limits by turning screws in direction shown on label. Decrease limits by turning screws in opposite direction.

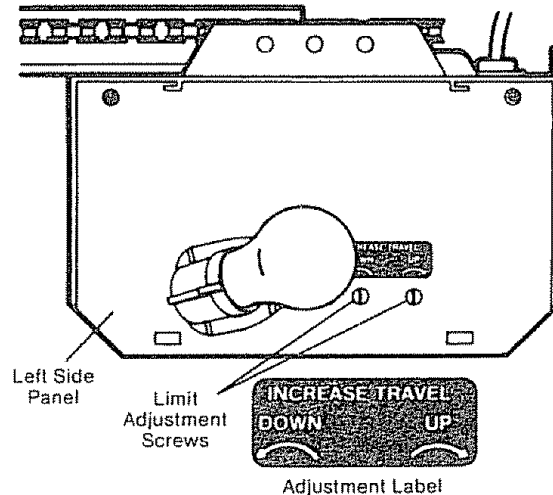

The following illustration shows the position of the door arm and trolley when the door is open (solid line drawing), and when the door is closed (dotted line drawing).

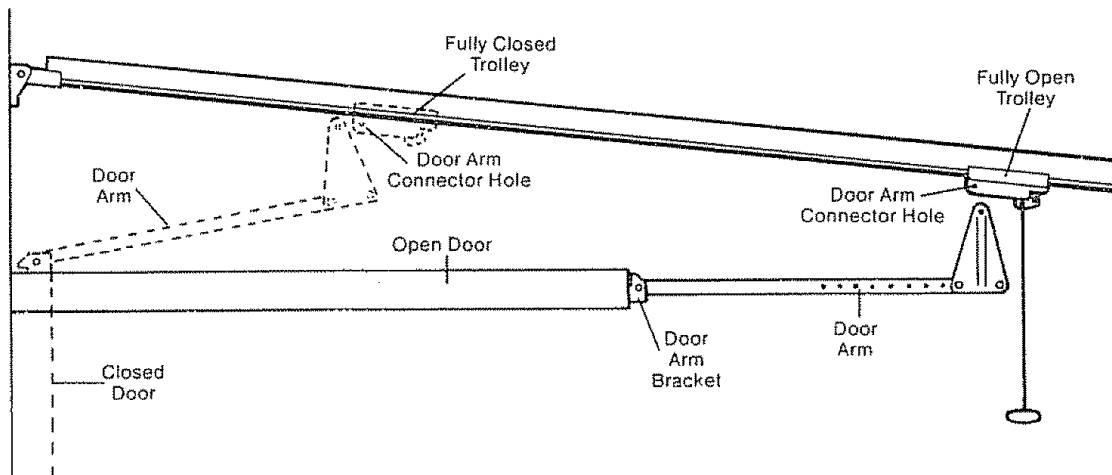

ADJUSTMENT PROCEDURES

PROCEDURE – OPEN DOOR ADJUSTMENT

DECREASE the UP limit by turning the UP limit adjustment screw counterclockwise 8 complete turns.

Press Wall Control push button. Trolley will travel to full open position.

Manually raise garage door to open position (parallel to floor) and lift door arm to trolley. The arm should touch trolley just in back of door arm connector hole as shown in solid line drawing. If the arm does not extend far enough, make further DECREASED limit adjustment. One full turn equals 2 inches of door travel.

PROCEDURE – CLOSED DOOR ADJUSTMENT

DECREASE the DOWN limit by turning the DOWN limit adjustment screw clockwise 4 complete turns.

Press Wall Control push button. Trolley will travel to full closed position.

Manually close garage door and lift door arm to the trolley. Arm should touch trolley just ahead of door arm connector hole as shown in dotted line drawing. If arm is behind the connector hole, make further DECREASED limit adjustment. One full turn equals 2 inches of door travel.

CONNECT DOOR ARM TO TROLLEY PROCEDURE: With door closed, join wedge door arm to connector hole in trolley with the remaining clevis pin. Secure with a cotter pin. **NOTE:** It may be necessary to lift door slightly to make connection.

Run the opener through a complete travel cycle. If door has a slight 'downward' slant in full open position, turn the UP limit adjustment screw counterclockwise to decrease travel until door is parallel to floor.

Adjustment

STEP 1 *Adjust UP and DOWN Limits*

The limit adjustment screws are located on the left side panel of the opener chassis as shown. LIMIT ADJUSTMENT settings regulate the points at which the door will stop when moving up or down.

NOTE: Door **STOPS** in UP direction if anything interferes with door travel. Door **REVERSES** in DOWN direction if anything interferes with door travel (including binding or unbalanced doors).

PROCEDURE: To operate opener, press Wall Control Push Button or transmitter push button. Run the opener through a COMPLETE TRAVEL CYCLE. No adjustments are needed when the door opens and closes completely and does not reverse unintentionally in down direction.

The following chart outlines adjustment procedures. Run opener through a COMPLETE TRAVEL CYCLE AFTER EACH ADJUSTMENT. **NOTE: REPEATED OPERATION OF THE OPENER DURING ADJUSTMENT PROCEDURES MAY CAUSE THE MOTOR TO OVERHEAT AND SHUT OFF. SIMPLY WAIT 15 MINUTES AND TRY AGAIN.** Read the chart carefully before proceeding to Step 2, Pg. 19. Use a screwdriver to make limit adjustments.

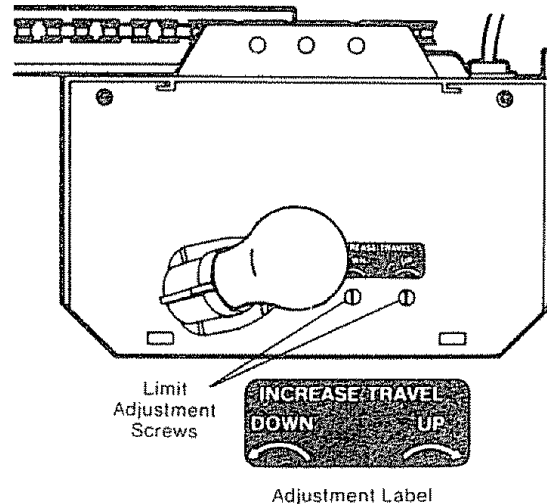

LIMIT ADJUSTMENT CHART

<p>IF DOOR DOES NOT OPEN COMPLETELY BUT OPENS AT LEAST FIVE FEET</p>	<p>Increase UP travel by turning UP LIMIT adjustment screw in clockwise direction as shown on label. One turn equals 2 inches of travel.</p> <p>If door doesn't open at least 5 feet, adjust OPEN FORCE as explained in Step 2, Page 19.</p>
<p>IF DOOR DOES NOT CLOSE COMPLETELY</p>	<p>1. ON SECTIONAL DOORS: Lengthen the door arm (See Step 10, Page 16). If door arm is at maximum length, increase the DOWN travel by turning the down limit adjustment screw in a counter clockwise direction as shown on label. One turn equals 2 inches of travel. If door still will not close completely, the header bracket is positioned too high. Repeat Step 2, Page 11</p> <p>2. ON ONE-PIECE DOORS: Increase DOWN travel by turning the down limit adjustment screw in a counterclockwise direction as shown on label. One turn equals 2 inches of travel.</p>
<p>IF DOOR REVERSES WHEN CLOSING AND THERE IS NO INTERFERENCE TO TRAVEL CYCLE</p>	<p>TEST DOOR FOR BINDING</p> <p>Pull emergency release handle and manually open and close the door. If door is binding, call a door serviceman.</p> <p>1. IF OPENER REVERSES BEFORE DOOR CLOSES FULLY: Adjust the CLOSE FORCE as explained in Step 2, Page 19.</p> <p>2. IF OPENER REVERSES IN FULLY CLOSED POSITION: Decrease DOWN travel. Turn the down limit adjustment screw in clockwise direction. One turn equals 2 inches of travel.</p>

Adjustment

STEP 2 Adjust Force



DO NOT USE FORCE ADJUSTMENTS TO COMPENSATE FOR A BINDING OR STICKING GARAGE DOOR. EXCESSIVE FORCE WILL INTERFERE WITH THE PROPER OPERATION OF THE SAFETY REVERSE SYSTEM OR DAMAGE THE GARAGE DOOR.

Force Adjustment Controls are located on right side panel of the opener chassis. **FORCE ADJUSTMENT** settings regulate the amount of power required to open and close the door.

NOTE: Door STOPS in UP direction if anything interferes with door travel. Door REVERSES in DOWN direction if anything interferes with door travel (including binding or unbalanced doors).

If force adjustments are set too light, door travel may be interrupted by nuisance reversals in the DOWN direction and stops in the UP direction. As weather conditions can affect door movement, occasional adjustment may be needed.

The maximum force adjustment range is 260 degrees, about 3/4 of a complete turn. Do not force controls beyond that point. Turn force adjustment controls with a screwdriver.

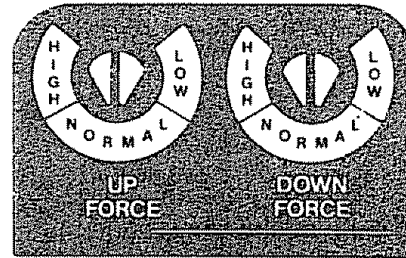
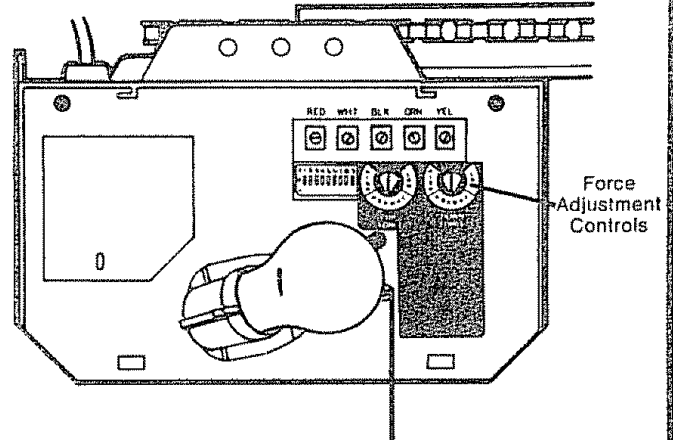

Adjustment Label

FORCE ADJUSTMENT CHART

<p>IF DOOR DOESN'T OPEN AT LEAST 5 FT:</p>	<p>Increase UP (OPEN) FORCE by turning control in a clockwise direction as shown on label. Make 10 degree turn adjustments until door opens completely. Readjust UP LIMIT if necessary. After each adjustment, run the opener through a complete travel cycle.</p>
<p>IF DOOR REVERSES DURING THE DOWN (CLOSE) CYCLE:</p>	<p>Increase DOWN (CLOSE) FORCE by turning control in a clockwise direction as shown on label. Make 10 degree turn adjustments until door completes the close cycle. After each adjustment, run opener through a complete travel cycle.</p>
<p>TEST DOWN (CLOSE) FORCE:</p>	<p>Grasp the door handle or door bottom when door is about halfway through DOWN (CLOSE) TRAVEL. The door should reverse. If the door is hard to hold or doesn't reverse, decrease the DOWN (CLOSE) FORCE by turning the control in a counter clockwise direction. Make 10 degree turn adjustments until the door reverses normally. After each adjustment, run the opener through a complete travel cycle.</p>

Adjustment

STEP 3 Test Safety Reverse System



THE SAFETY REVERSE SYSTEM TEST IS IMPORTANT. THE GARAGE DOOR *MUST* REVERSE ON CONTACT WITH A ONE INCH OBSTACLE PLACED ON THE FLOOR. FAILURE TO PROPERLY ADJUST THE OPENER MAY RESULT IN SERIOUS PERSONAL INJURY FROM A CLOSING GARAGE DOOR. REPEAT THE TEST AT LEAST ONCE A YEAR AND MAKE ANY NEEDED ADJUSTMENTS.

PROCEDURE: Place a 1-inch obstacle on the floor under the garage door. Operate the door in the DOWN direction. The door must reverse on the obstruction.

If a **SECTIONAL** door STOPS on the obstruction, lengthen door arm (Step 10, Page 16) until the door reverses in DOWN direction.

If a **ONE-PIECE** door stops on obstruction, door is not traveling far enough in DOWN direction. Increase the DOWN limit by turning the DOWN limit adjustment screw counter-clockwise 1/4 turn. REPEAT TEST.

When the door reverses on the 1-inch obstruction, remove obstruction and run opener through a complete travel cycle. Door must not reverse in closed position. If it does, repeat Adjustment Steps 2 and 3.

SECTIONAL DOOR

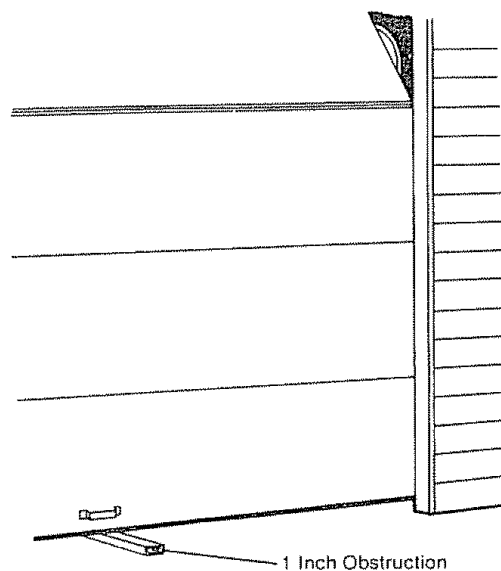

ONE-PIECE DOOR

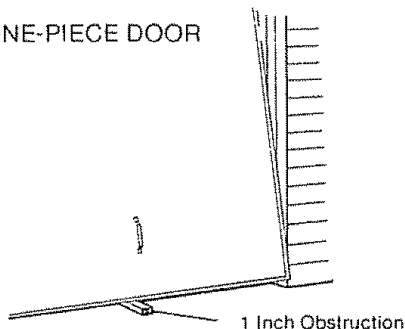

REPEAT ADJUSTMENT STEP 3 AFTER:



1. EACH ADJUSTMENT OF DOOR ARM LENGTH, CLOSE FORCE OR DOWN LIMIT
2. ANY REPAIR OR ADJUSTMENT OF THE GARAGE DOOR (INCLUDING SPRINGS AND HARDWARE)
3. ANY REPAIR OR BUCKLING OF THE GARAGE FLOOR
4. ANY REPAIR OR ADJUSTMENT OF THE GARAGE DOOR OPENER

(Optional) STEP 4 Install Infrared Reversing System

The INFRARED REVERSING SENSOR provides an **ADDITIONAL** measure of safety against small children being caught under a garage door. It uses an invisible beam which, when broken by an obstruction, causes a closing door to open or prevents an open door from closing.

After the garage door opener has been completely installed and adjusted, the INFRARED REVERSING SENSOR accessory can be installed. Instructions are included with this optional device.

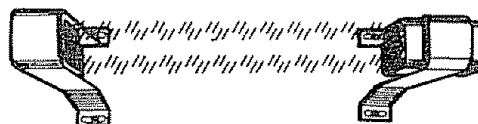

CAUTION: The Infrared Reversing Sensor will not be in effect when Vacation Light is ON.

Operation of Your Opener

CAUTION:

- **START BY READING THE SAFETY RULES ON PAGE 3.**
- **READ THE OPERATING INSTRUCTIONS ON THIS PAGE CAREFULLY.**
- **DO NOT PERMIT CHILDREN TO PLAY IN AREA OF DOOR.**
- **OPERATE ONLY WHEN OPENER IS PROPERLY ADJUSTED AND DOOR IS IN SIGHT AND FREE OF OBSTRUCTION.**



THE SAFETY REVERSE SYSTEM IS IMPORTANT (SEE PAGE 20). GARAGE DOOR *MUST* REVERSE ON CONTACT WITH A ONE-INCH OBSTACLE PLACED ON THE FLOOR. FAILURE TO PROPERLY ADJUST OPENER MAY RESULT IN SERIOUS PERSONAL INJURY FROM A CLOSING GARAGE DOOR. REPEAT THE TEST AT LEAST ONCE A YEAR AND MAKE NEEDED ADJUSTMENTS.

USING THE OPENER

Your garage door opener can be activated by any of the following methods:

1. Pressing the transmitter push button. Hold the button down until door starts to move.
2. Pressing the Wall Control push button.
3. By turning the Key Switch (if you have installed this accessory).

WHEN EITHER THE WALL CONTROL OR TRANSMITTER PUSH BUTTONS ARE PRESSED, ONE OF THE FOLLOWING WILL OCCUR (Vacation Light OFF):

1. If open, the door will close. If closed, the door will open.
2. If closing, the door will reverse.
3. If opening, the door will stop (allowing space for entry and exit of pets and for fresh air).
4. If the door has been stopped in a partially open position (refer to 3. above), it will close.
5. If an obstruction is encountered while closing, the door will reverse.
6. If an obstruction is encountered while opening, the door will stop.
7. The optional Infrared Reversing Sensor, if installed, will signal the opener to reverse the door in the closing cycle when the IR beam is obstructed and prevent an open door from closing. It has no effect in the opening cycle.

THE LIGHTS

When the opener is activated, lights will turn on. They will turn off automatically after 4-1/2 minutes BULB SIZE-75 watts maximum. When Work Light is ON, the lights will remain on.

OPENING THE DOOR MANUALLY

The door can be operated manually by disconnecting it from the opener. Simply pull down sharply on the red emergency release handle. The door may now be lifted manually. **DO NOT USE EMERGENCY ROPE AND HANDLE TO PULL THE DOOR OPEN OR CLOSED.** To automatically reconnect the door to the opener, press the Wall Control push button.

CARE OF THE OPENER

When properly installed, your opener will perform efficiently with a minimum of maintenance. You will be required to replace a light bulb or change a transmitter battery from time to time. A 9-Volt Alkaline battery is the most reliable, and is available at Sears.

The opener does not require additional lubrication - **HOWEVER** - the door rollers, bearings and hinges should be oiled yearly.

Most complaints of unsatisfactory opener operation can be traced to problems with the door itself. The opener is not intended to correct problems caused by an unbalanced or binding door, broken door springs or faulty door hardware. When operating the door manually, a properly balanced door will stay in any point of travel while being supported solely by its springs. If you encounter any difficulty when operating door manually, call a garage door serviceman.

RADIO CONTROLS

Refer to pages 22 and 23 for complete details.

OPENER ADJUSTMENTS

Refer to pages 18 and 19 for limit and force adjustments. These adjustments must be checked and properly set when opener is installed. Weather conditions may cause minor changes in door operation requiring some change in adjustments, particularly during the first year of operation. Only a screwdriver is required. Follow instructions carefully.

Radio Controls

Sears Trinary Radio Control

Manufactured under 1 or more of the following U.S. patents: 3,906,348; and 4,037,201

RECEIVER

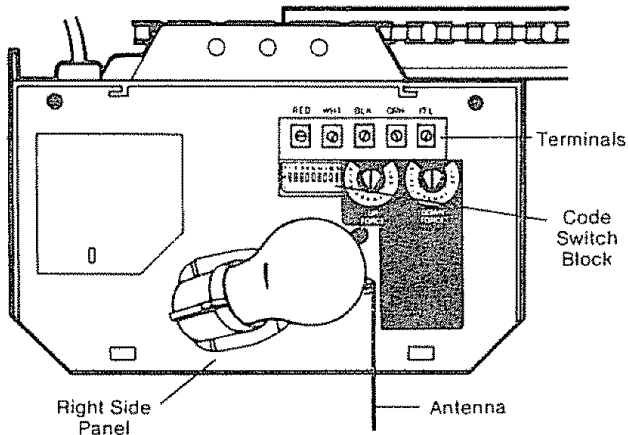

RADIO CONTROLS consist of two 3-channel transmitters and a receiver. The coded signal is factory preset.

The garage door opener will operate by pressing the Wall Control push button or by pressing the TOP (large) transmitter push button.

In addition, each transmitter push button can operate one or more remote control devices (including any other 19,683 code garage door opener).

Page 23 explains how to change your existing code and how to use the transmitter(s) with other remote control devices.

Self service of your radio controls is not recommended. If service is needed, contact your nearest Sears Service Center.

THE TRANSMITTER

Each portable transmitter may be secured to a car sun visor with the clip provided. Extra transmitters can be purchased at any time. (Refer to Accessories, Page 5). Code setting procedures are described on Page 23

A 9-volt battery supplies the power. The transmitter is equipped with a battery check light. When the transmitter push button is pressed, light will glow if battery has power (and the opener or other remote control device will operate). When light does not come on, replace battery. If transmission range lessens, check battery light.

THE BATTERY

The battery should produce adequate power for approximately one year. Avoid the inconvenience of unexpected battery failure by replacing it annually, preferably before winter. Alkaline batteries are the most reliable and are available at Sears.

TO REPLACE BATTERY: Remove visor clip and unfasten connecting screw. Remove top of transmitter case and discard old battery. Snap connector onto new battery. Reassemble case. Replace visor clip.

TRANSMITTER

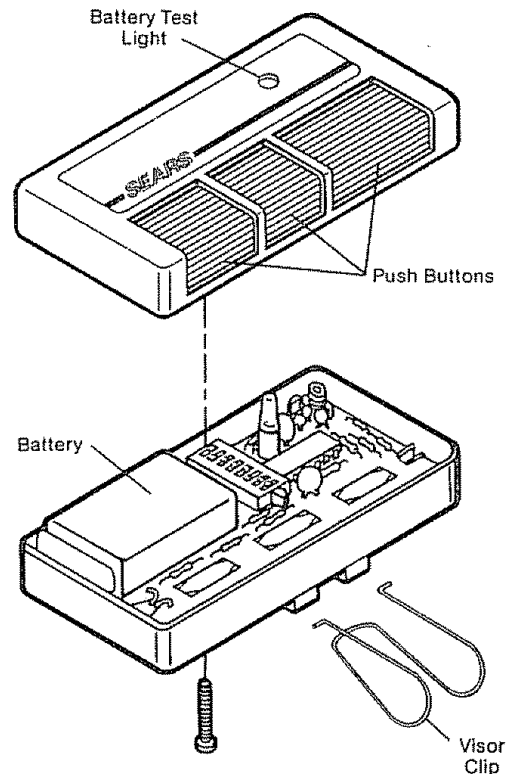

Radio Controls

The position (+, - or 0) of RECEIVER code switch No. 1 sets the transmitter to operate from ONE of its push buttons. The positions of RECEIVER and TRANSMITTER code switches 2 through 9 set the signal code. Changing the position of only one switch makes a new code.

Instructions are given below for changing codes and/or using the transmitter(s) with additional receivers. **NOTE: If you change the code in one receiver, you must set transmitter(s) and ALL other remote control receivers to the same code.**

SETTING/CHANGING YOUR CODE IN RECEIVER(S) AND TRANSMITTER(S)



DISCONNECT POWER TO OPENER (OR OTHER DEVICES) BEFORE SETTING OR CHANGING THE CODE IN THE RECEIVER(S).

IMPORTANT: THE POSITION OF CODE SWITCH NO. 1 ON THE RECEIVER MUST BE SET TO MATCH TRANSMITTER PUSH BUTTON SELECTED.

1. Select a transmitter push button to operate the receiver. Large push button is recommended for use with a garage door opener and has been factory preset.
2. Remove screw on back of transmitter(s). Carefully turn case over (push button side up).
3. Remove case top. **CAUTION: Be careful not to move circuit board components.**
4. Locate the RECEIVER code switch block.

- **FOR TOP (LARGE) TRANSMITTER PUSH BUTTON:** Set RECEIVER code switch 1 to minus (-).
- **FOR CENTER TRANSMITTER PUSH BUTTON:** Set RECEIVER code switch 1 to neutral (0).
- **FOR BOTTOM TRANSMITTER PUSH BUTTON:** Set RECEIVER code switch 1 to plus (+).

To complete the code setting, use a pen or screwdriver. Beginning with code switch 2 on the receiver, slide one or more of the switches to plus, minus or neutral (0).

Hold transmitter(s) alongside receiver code switch. Set code switches in transmitter(s) to match receiver switch positions.

NOTE: Code switches 2 through 9 on ALL the receivers operated by the transmitter(s) must MATCH switches 2 through 9 in transmitter(s).

CAUTION: If you press more than ONE push button at the same time, transmitter will not operate.

TRANSMITTER

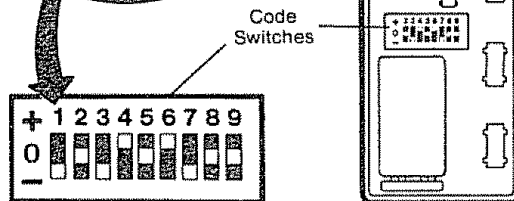
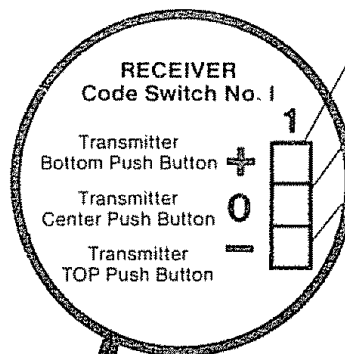
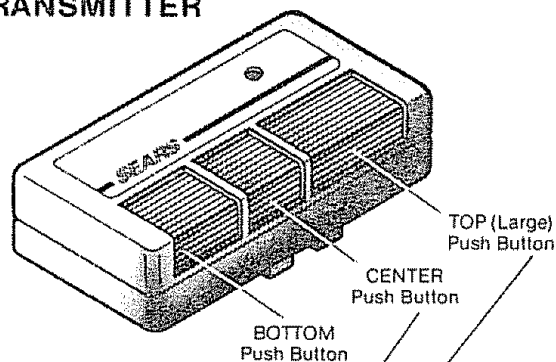

RECEIVER

TRANSMITTER

PLEASE KEEP THIS INSTRUCTION MANUAL HANDY FOR FUTURE REFERENCE.

Having a Problem?

OPENER DOESN'T ACTIVATE

1. Have you removed all door locks and bolts?
2. Does the opener have electric power? Check wall switch, fuse, etc.
3. Is there a broken wire between Wall Control and opener? Check under staples. (A positive check can be made by temporarily installing another wire).
4. Are wiring connections correct? Refer to Step 7, Page 14
5. Repeated operation may have tripped the overload protector in the motor. Wait 15 minutes. Try again.

TRANSMITTER RANGE INSUFFICIENT

1. Check battery.
2. Change transmitter location in car.
3. Metal garage door, foil-backed insulation or metal siding will reduce range.
4. Antenna on side panel of opener must be fully extended downward.

DOOR DOESN'T OPEN OR CLOSE COMPLETELY

1. Is something obstructing the door?
2. Limits may need adjustment. See Pg. 18
3. Force may need adjustment. See Pg. 19.
4. Door will not close while Vacation Light is ON.

DOOR OPENS AND CLOSES BY ITSELF

1. Neighbor with a Sears opener using the same code? Change your code.

LIGHTS

1. Won't turn OFF? Check Work Light. Is it ON?
2. Won't turn ON? Check light bulbs.

DOOR OPERATES FROM WALL CONTROL BUT NOT FROM TRANSMITTER

1. Replace the battery.
2. New transmitter? Have you set the code? Refer to Page 23
3. Is transmitter operating additional remote control devices? See code setting procedure on Page 23.
4. Did you press transmitter button designated to operate garage door opener?
5. Vacation light is ON.

DOOR REVERSES FOR NO APPARENT REASON

1. Pull red emergency release handle. Operate the door manually. Is it balanced? Binding? If service is needed call a garage door serviceman.
2. Force adjustment may be needed. See Pg. 19.
3. Check for proper alignment of Infrared Reversing Sensor (if you have installed this accessory).
4. Clear ice and snow from garage floor area where garage door closes.

THE NEED FOR OCCASIONAL ADJUSTMENT OF FORCE AND LIMIT CONTROLS IS NORMAL. WEATHER CONDITIONS IN PARTICULAR CAN AFFECT DOOR MOVEMENT.

Transmitter Schematic

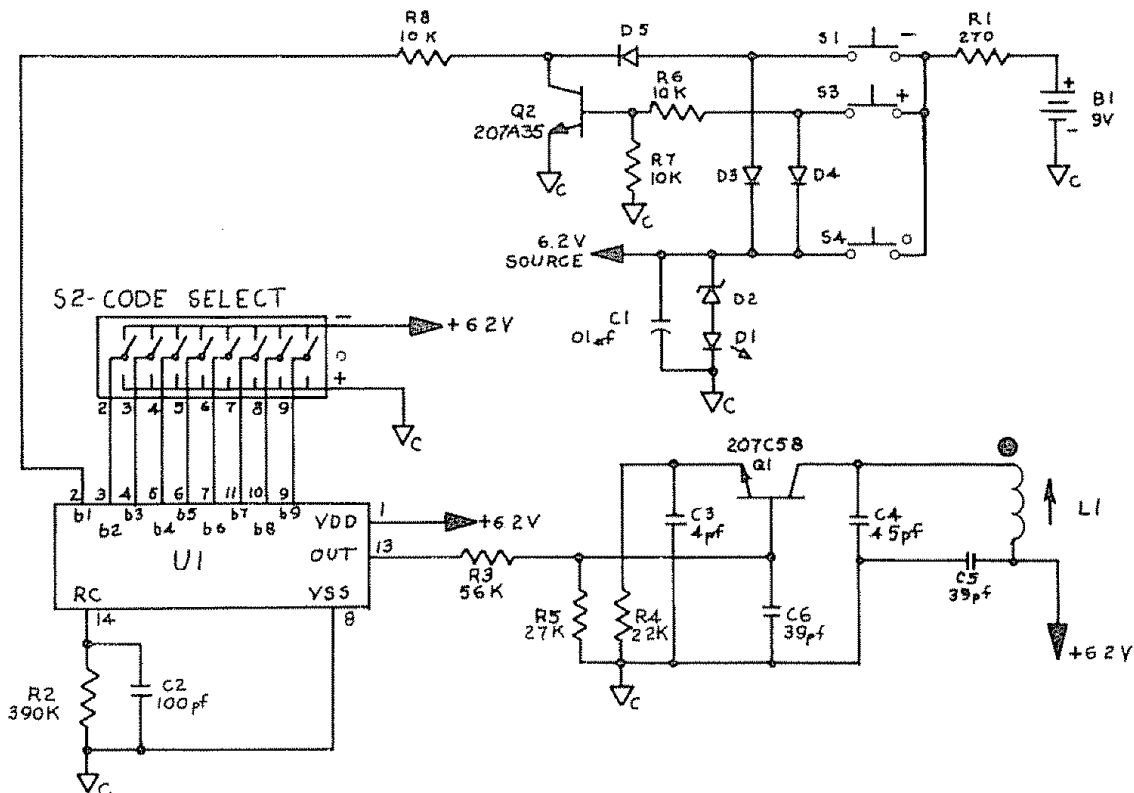

Wiring Diagram and Receiver Schematic

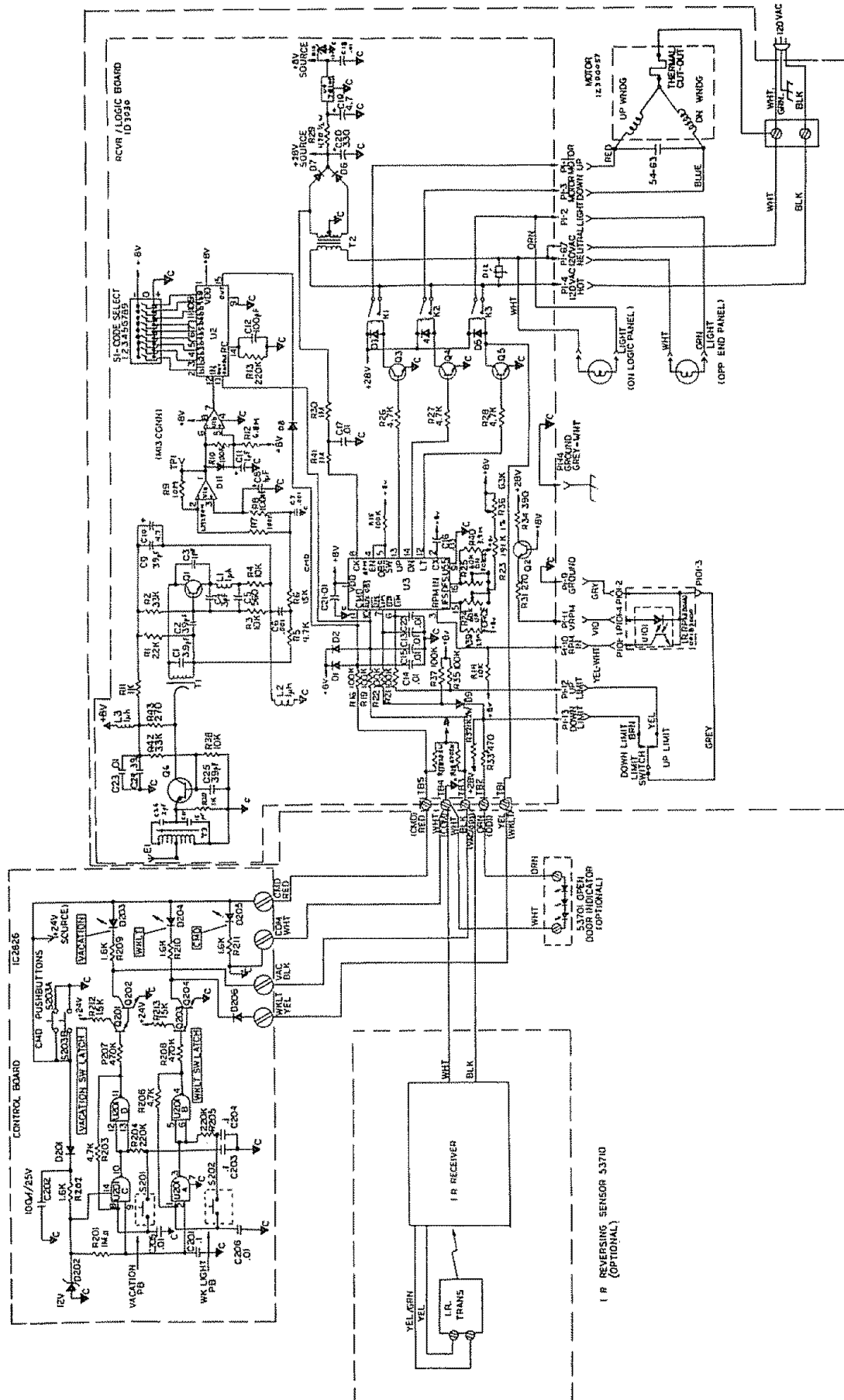

Repair Parts

RAIL ASSEMBLY PARTS LIST

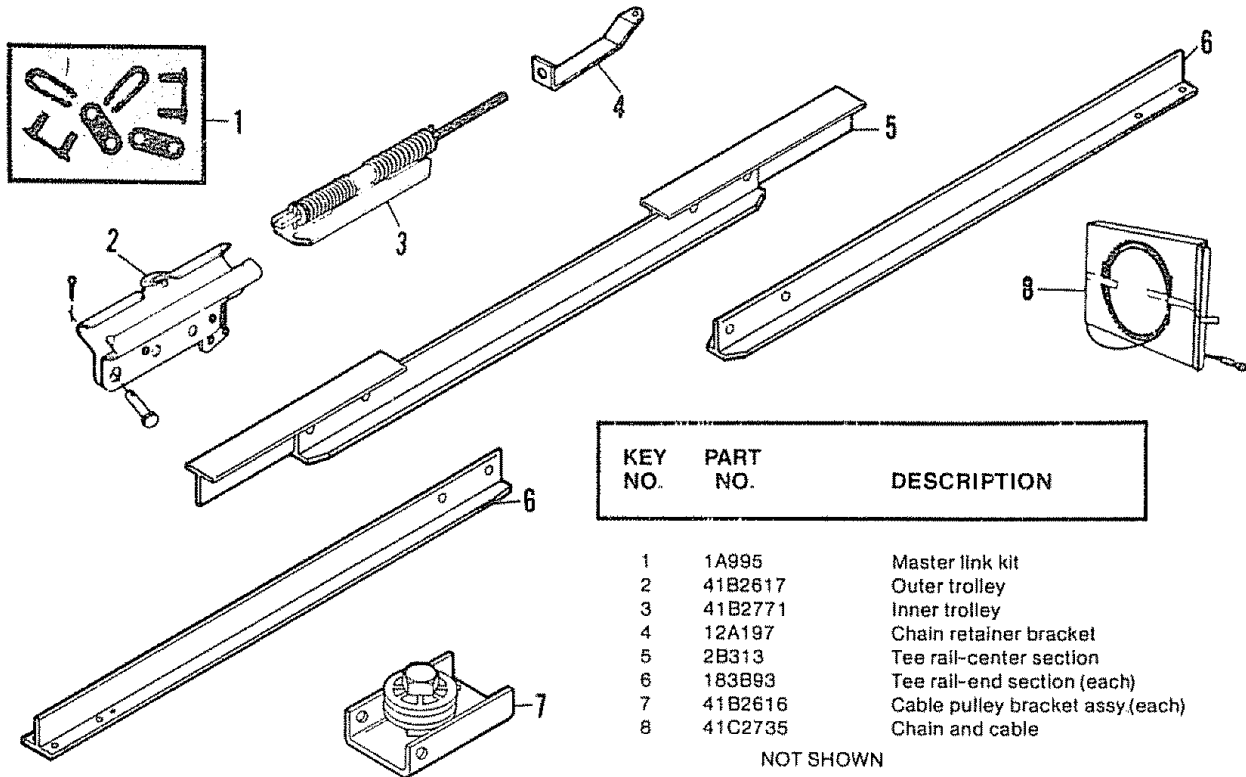

KEY NO.	PART NO.	DESCRIPTION
---------	----------	-------------

- | | | |
|---|---------|----------------------------------|
| 1 | 1A995 | Master link kit |
| 2 | 41B2617 | Outer trolley |
| 3 | 41B2771 | Inner trolley |
| 4 | 12A197 | Chain retainer bracket |
| 5 | 2B313 | Tee rail-center section |
| 6 | 183B93 | Tee rail-end section (each) |
| 7 | 41B2616 | Cable pulley bracket assy.(each) |
| 8 | 41C2735 | Chain and cable |

NOT SHOWN

41A2814 Rail assy hardware kit (includes hardware illustrated on Page 4)

INSTALLATION PARTS LIST

KEY NO.	PART NO.	DESCRIPTION
---------	----------	-------------

- | | | |
|----|----------|---|
| 1 | 41D2736 | Wall control assy |
| 2 | 10A13 | 9 volt battery (available at Sears) |
| 3 | 41A3012 | Transmitter case, cover and screw assy |
| 4 | 29C121-2 | Transmitter visor clip |
| 5 | 41A2828 | Emergency rope and handle assy |
| 6 | 219A319 | 4-Strand bell wire |
| 7 | 41A2829 | Header bracket plus cotter pin and clevis |
| 8 | 12B374 | Door bracket |
| 9 | 12B380 | Door bracket plate |
| 10 | 178B32 | Wedge door arm section |
| 11 | 178B33 | Straight door arm section |

NOT SHOWN

41A2815 Installation hardware bag (includes hardware illustrated on Page 4)

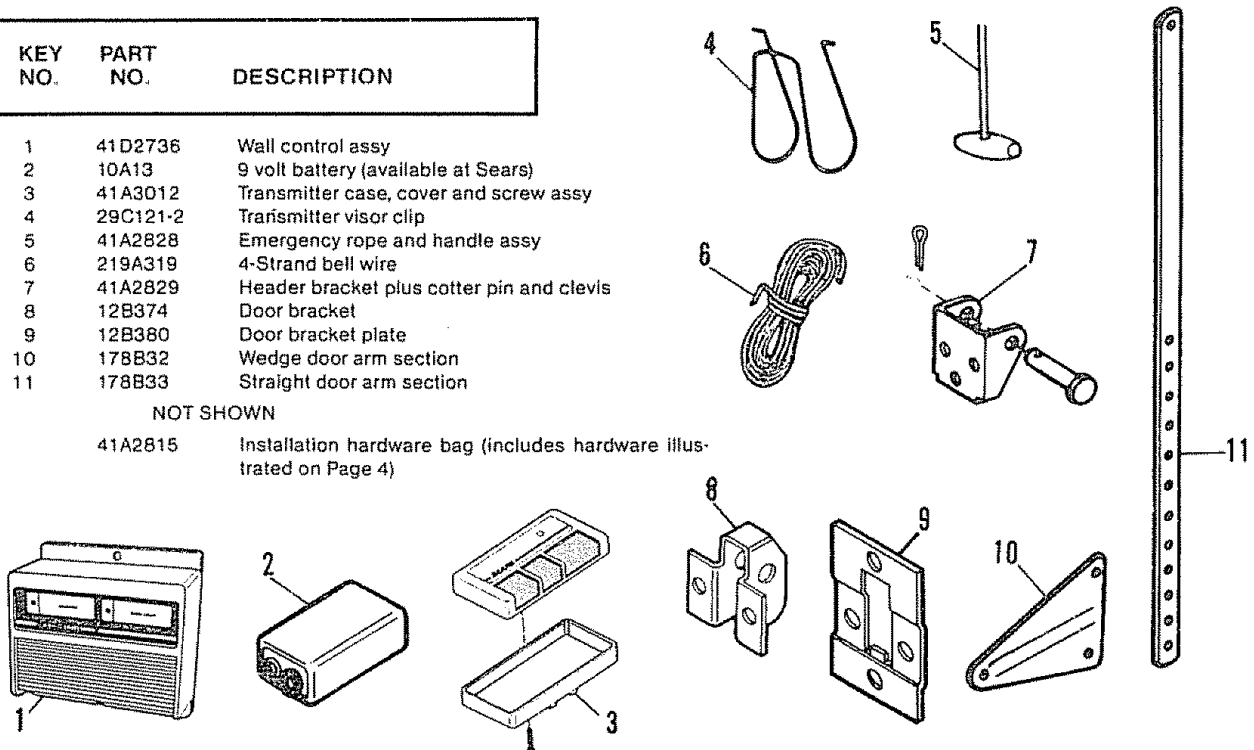

Repair Parts

Chassis Assembly Parts List

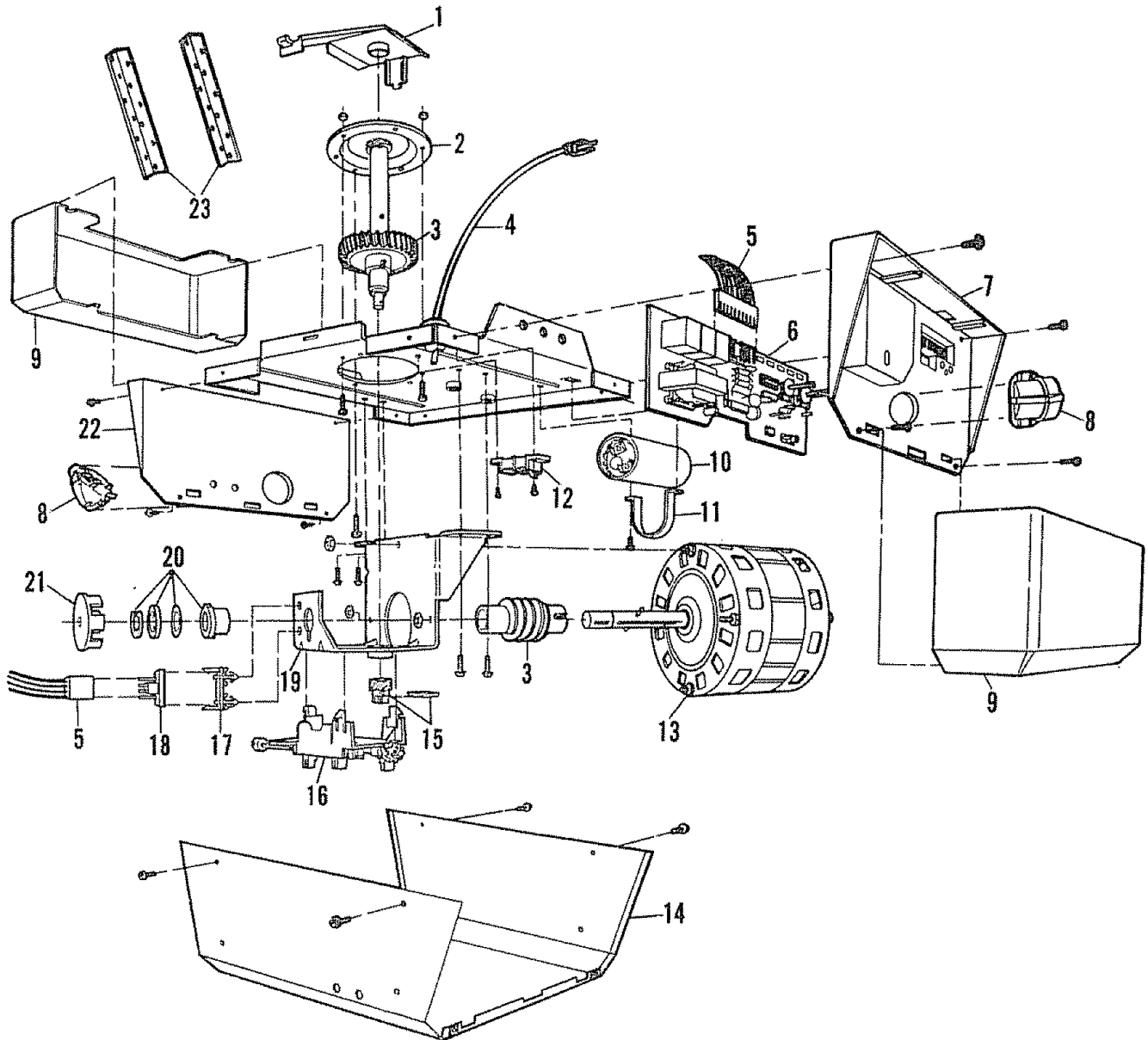

KEY PART NO.	PART NO.	DESCRIPTION
--------------	----------	-------------

1	31C290	Sprocket cover
2	41A2827	Gear and sprocket assy Complete with: Spring washer Thrust washer Retaining ring Bearing plate Roll pins (2) Drive gear Worm gear Helical gear w/retainer Grease
3	41A2817	Drive/worm gear kit w/grease Roll pins (2)
4	41B2991	Line cord
5	41C2725	Wire harness assy w/plug
6	41A3063	Receiver logic board assy. Logic board End panel w/all labels Light socket (1)
7	41A3073	End panel w/all labels
8	175B88	Light socket (each)

KEY PART NO.	PART NO.	DESCRIPTION
--------------	----------	-------------

9	108D30-1	Lens (each)
10	30B363	Capacitor
11	12A373	Capacitor bracket
12	1A2510	Terminal block w/screws
13	41A2821	Motor assy w/roll pin
14	41C2740	Cover w/all labels
15	41A2818	Helical gear and retainer w/grease
16	41D3013	Limit switch assembly
17	41A3020	RPM sensor retainer
18	41B3000	RPM sensor
19	41A3027	Motor bracket and bearing assy.
20	41A2826	Shaft bearing kit
21	41A2822	Interrupter cup assy.
22	41A3074	End panel
23	12B350	Hanging brackets

NOT SHOWN

114A866	Owners manual
41A2825	Chassis assy. hardware kit (includes screws not designated by number in illustration)

Owners Manual

Sears Best

CRAFTSMAN®

**Garage
Door
Opener
Model
139.53513**

HOW TO ORDER REPAIR PARTS

Now that you have purchased your Sears Garage Door Opener, should a need ever exist for repair parts or service, simply contact any Sears Service Center and most Sears, Roebuck and Co. stores. Be sure to provide all pertinent facts when you call or visit.

The MODEL NUMBER of your garage door opener is printed on a label located on the right side panel of the opener chassis.

All parts listed may be ordered from any service center and most Sears stores.

WHEN ORDERING REPAIR PARTS, ALWAYS GIVE THE FOLLOWING INFORMATION:

- PART NUMBER
- PART DESCRIPTION
- MODEL NUMBER
- NAME OF ITEM

If the parts you need are not stocked locally, your order will be electronically transmitted to a Sears Repair Parts Distribution Center for handling.

IMPORTANT NOTE: If you suspect radio malfunction, contact your nearest SEARS Service Center.

MAINTENANCE AGREEMENTS ... YOUR WAY TO BUY TOMORROW'S SERVICE AT TODAY'S PRICE ... With nationwide service and the benefits of a Sears warranty plus a Sears Maintenance Agreement, you don't have to worry about costly repairs resulting from normal use.

The Maintenance Agreement does not cover installation or re-installation of the product or damage resulting from external causes such as: acts of abuse, fire, flood, wind, lightning, freezing, etc.

To Purchase a Sears Maintenance Agreement - Ask Any Salesperson or Call Sears Service Today.

SEARS WARRANTY

GARAGE DOOR OPENER MODEL 139.53513

FULL 90 DAY WARRANTY ON GARAGE DOOR OPENER

For 90 days from the date of purchase, Sears will repair this Garage Door Opener, free of charge, if defective in material or workmanship.

LIMITED WARRANTY

From the 91st day until one year from the date of purchase, Sears will furnish replacement parts for any defective parts, free of charge. You pay for labor.

LIMITED WARRANTY ON MOTOR

After 1 year and through 5 years, if the motor on this Garage Door Opener is defective, Sears will furnish a replacement motor, free of charge. You pay for labor.

LIMITATION ON LIABILITY

Sears will not be liable for loss or damage to property or any incidental or consequential loss or expense from property damage due directly or indirectly from the use of this product.

Some states do not allow the exclusion or limitation of incidental or consequential damages, so the above limitation or exclusion may not apply to you.

This warranty does not cover repairs necessary because of operator abuse or negligence, including the failure to install, adjust and operate this garage door opener according to the instructions contained in the owner's manual.

WARRANTY SERVICE IS AVAILABLE BY SIMPLY CONTACTING THE NEAREST SEARS SERVICE CENTER/DEPARTMENT IN THE UNITED STATES. This warranty applies only while the product is in use in the United States.

This warranty gives you specific legal rights, and you may also have other rights which vary from state to state.

SEARS ROEBUCK AND COMPANY, Dept. 898/731A Sears Tower, , Chicago, IL 60684