

# Owner's Manual

Model No.  
139.53663SRT

For Residential Use  
Only

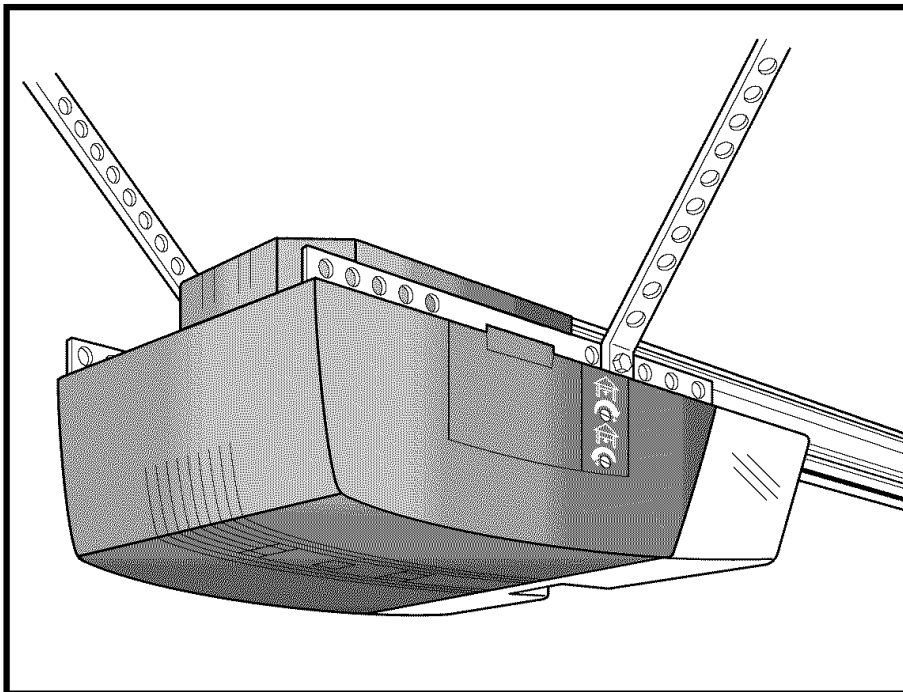

## **CRAFTSMAN**® GARAGE DOOR OPENER 1/2 HP

**Caution:**  
Read and follow all  
safety rules and  
operating instructions  
before first use of this  
product.

Fasten the manual  
near the garage door  
after installation.

- Safety Precautions
- Assembly
- Installation
- Adjustment
- Care and Maintenance
- Operation
- Troubleshooting
- Parts List

Complies with UL 325  
regulations effective  
January 1, 1993



Sears, Roebuck and Co., Hoffman Estates, IL 60179 U.S.A.

# Contents

Safety alert symbol review.....	2	Complete the safety reversing sensor installation.....	22
Safety information, precautions, tools .....	3	Install the lights and lens .....	23
Testing your garage door for binding & balance .....	3	Attach the emergency release rope and handle.....	23
Carton inventory .....	4	Fasten the door bracket (sectional door).....	24
Hardware inventory.....	5	Fasten the door bracket (one-piece door).....	25
Illustration of sectional door installation .....	6	Connect door arm to trolley (sectional door).....	26
Illustration of one-piece door installation.....	7	Connect door arm to trolley (one-piece door).....	27
<b>Assembly section - pages 8 – 11</b>		<b>Adjustment section - pages 28 – 30</b>	
Assemble the rail .....	8	Travel limit adjustments.....	28
Fasten rail to power unit.....	10	Force adjustments .....	29
Install the trolley .....	10	Test the safety reversing sensor .....	30
Attach the rail brackets .....	11	Test the safety reverse system .....	30
<b>Installation section - pages 12 – 27</b>		Operation safety instructions .....	31
Installation safety instructions .....	11	Care of your opener .....	31
Determine the header bracket location		Maintenance schedule.....	31
Sectional door .....	12	Operation of your opener.....	32
One-piece door.....	13	Receiver & remote control programming .....	33
Install the header bracket .....	14	Troubleshooting .....	34
Attach the rail to the header bracket .....	15	Repair parts, rail assembly.....	36
Safety reversing sensor information .....	16	Repair parts, installation .....	36
Install the safety reversing sensor .....	17	Repair parts, power unit.....	37
Position the opener.....	19	Accessories .....	38
Hang the opener.....	20	Index .....	39
Install the door control and connect all wires .....	21	How to order repair parts .....	40
Electrical requirements .....	22	Warranty.....	40

Start by reviewing these important safety alert symbols:

When you see these Safety Symbols on the following pages, they will alert you to the possibility of *serious injury or death* if you do not comply with the corresponding instructions. The hazard may come from something mechanical or from electric shock. *Read the instructions carefully.*



**WARNING**

**Mechanical**



**WARNING**

**Electrical**

When you see this Safety Symbol on the following pages, it will alert you to the possibility of damage to your garage door and/or the garage door opener if you do not comply with the corresponding instructions. *Read the instructions carefully.*



**CAUTION**

This garage door opener is designed and tested to offer safe service provided it is installed, operated, maintained and tested in strict accordance with the safety instructions contained in this manual.

# Safety Information and Precautions; Tools



## WARNING

*An unbalanced garage door might not reverse when required and someone under the door could be seriously injured or killed.*

If your garage door binds, sticks or is out of balance, call for professional garage door service. *Garage doors, door springs, cables, pulleys, brackets, and their hardware are under extreme tension and can cause serious injury or death. Do not try to loosen, move or adjust them yourself!*

*Ropes left on a garage door could cause someone to become entangled and killed. Remove all ropes connected to the door before installing and operating the opener.*



## CAUTION

To avoid damage to the garage door and opener, disable locks before installing and operating the opener. Use a wood screw or nail to hold locks in the "open" (unlocked) position.

Operation at other than 120V 60 Hz will cause opener malfunction and damage.

Identify the type and height of your door, any special conditions that exist, and any additional materials that may be required. Refer to pages 6 and 7.

### Test Your Door for Balance

Before you begin, complete the following test to make sure your door is balanced, and is not sticking or binding:

- Lift the door about halfway as shown. Release the door. It should stay in place, supported entirely by its springs.
- Raise and lower the door to see if there is any binding or sticking.

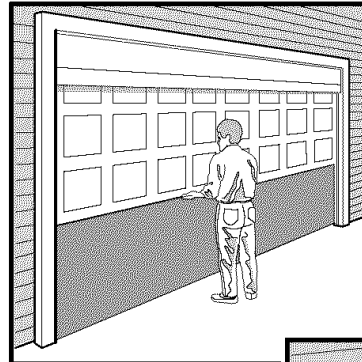

Sectional Door

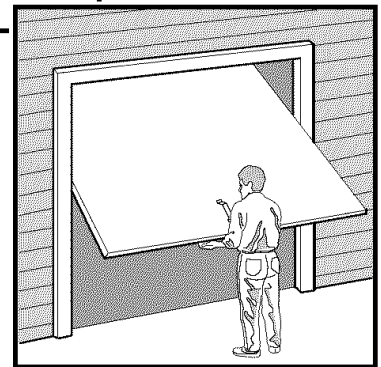

One-Piece Door

During assembly, installation and adjustment of the opener, instructions will call for tools shown below.

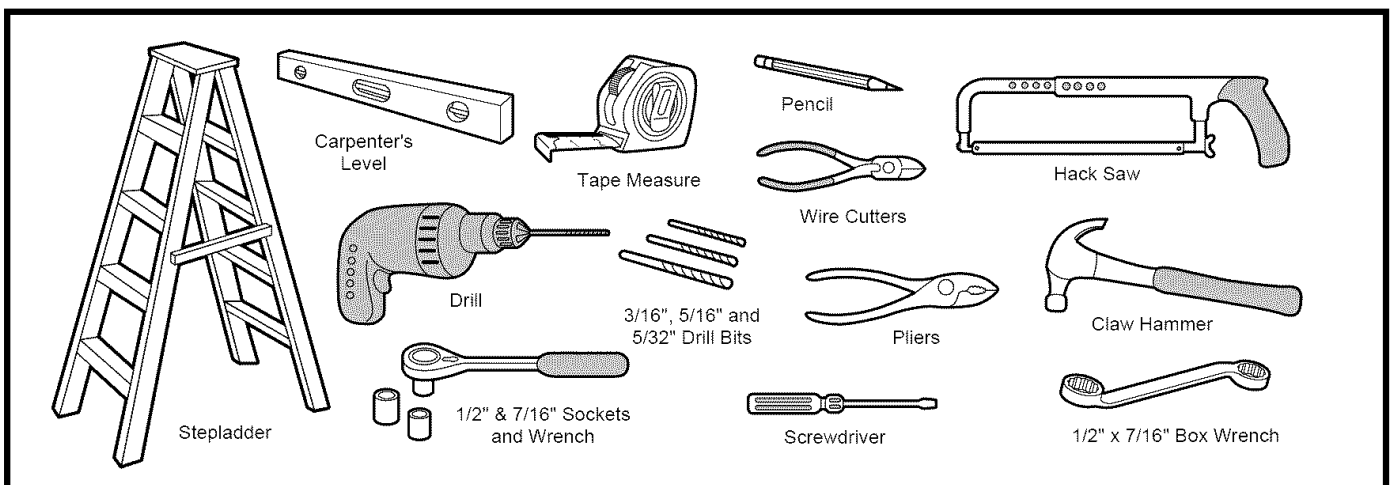

# Carton Inventory

Your garage door opener is packaged in one carton which contains the power unit and all parts illustrated below. If anything is missing, carefully check the packing material. Parts may be "stuck" in the foam. **KEEP THE FOAM INTACT** (see page 10). Hardware for assembly and installation is shown on page 5.

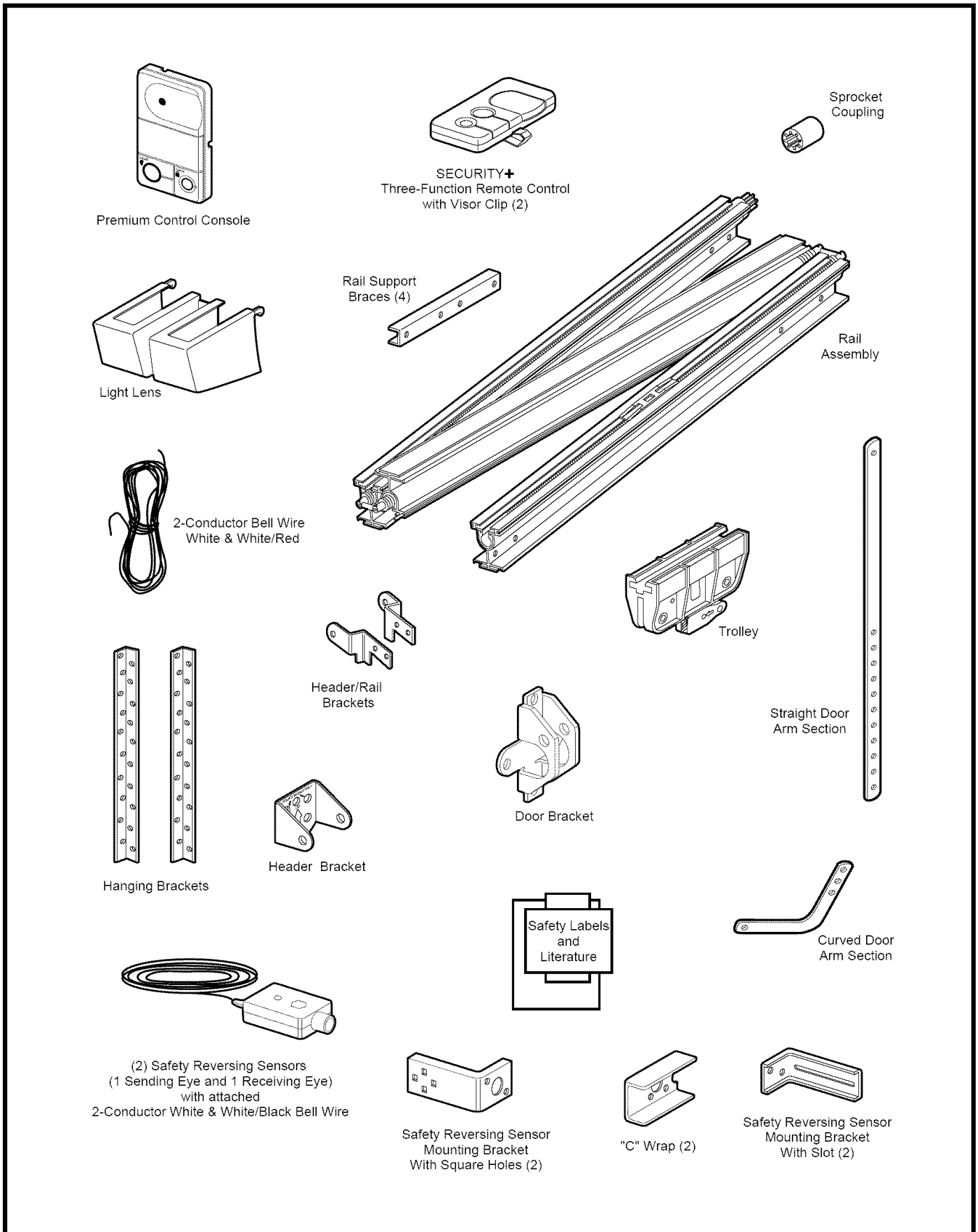

# Hardware

Separate all hardware from the packages in the rail carton and the opener carton and group as shown below, for the assembly and installation procedures.

## Assembly Hardware

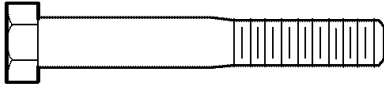

Bolt  
1/4-20x1-3/4" (8)

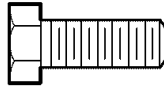

1/4" - 20 x 5/8"  
Hex Screw (4)

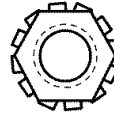

Lock Nut  
1/4"-20 x 7/16 (12)

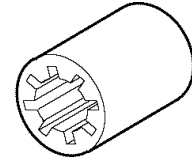

Sprocket Coupling Sleeve

## Installation Hardware

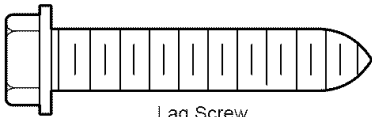

Lag Screw  
5/16"-9x1-5/8" (2)



Ring  
Fastener (3)



Nut 5/16"-18 (6)



Handle

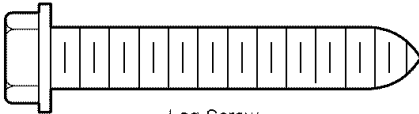

Lag Screw  
5/16"-18x1-7/8" (2)

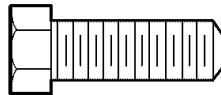

Hex Screw  
5/16"-18x7/8" (4)



Insulated  
Staples (10)



Lock Washer 5/16" (6)

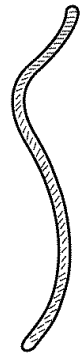

Rope

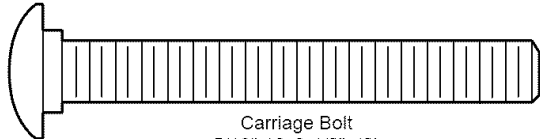

Carriage Bolt  
5/16"-18x2-1/2" (2)



Screw  
6ABx1" (2)

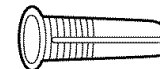

Dry Wall Anchors (2)

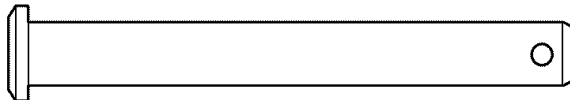

Clevis Pin  
5/16"x2-3/4" (1)

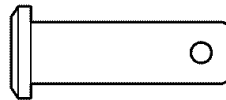

Clevis Pin  
5/16"x1" (1)



Clevis Pin  
5/16"x1-1/4" (1)

## Safety Reversing Sensor Installation Hardware



Lag Screw  
1/4x1-1/2" (4)

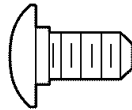

Carriage Bolt  
1/4"-20x1-1/2" (4)

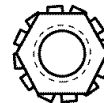

Lock Nut  
1/4"-20 x 7/16 (4)



Wing Nut (2)



Hex Screw  
1/4-20x1-1/2" (2)



Screw  
#10-32x3/8" (4)



Lock Nut  
#10x32 (4)

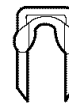

Insulated  
Staples (20)

# SECTIONAL Door Installation

Before you begin, survey your garage area to see whether any of the conditions below apply to your installation.

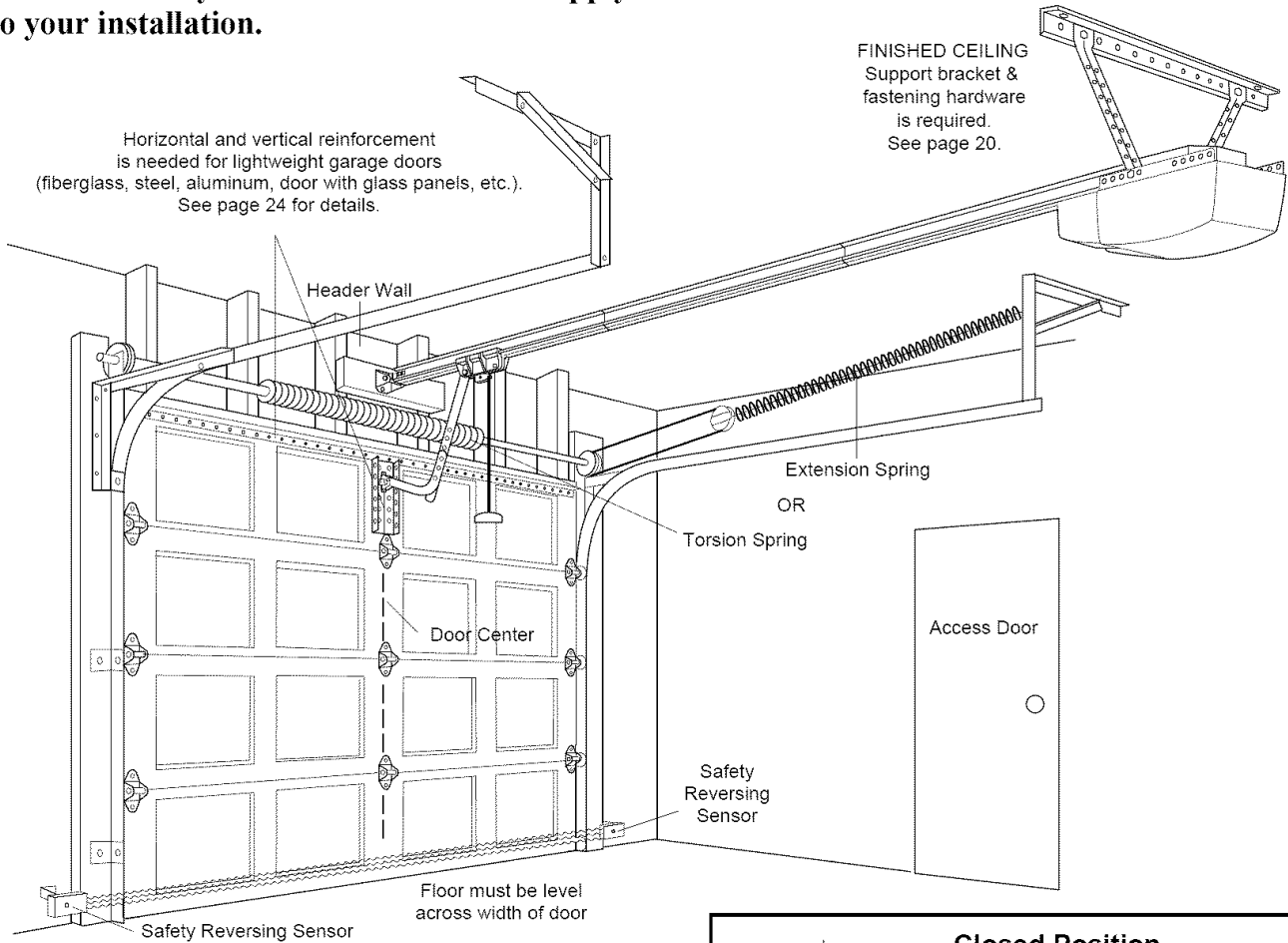

Based on your particular requirements, there are several installation steps which might call for materials and/or hardware not included in the carton.

- Step 1, page 12 – Look at the wall or ceiling above the garage door. The header bracket *must* be securely fastened to structural supports.
- Safety reversing sensor, page 16 – Depending upon garage construction, wood blocks may need to be fastened to mounting locations before sensors are installed.
- Step 4, page 17 – Alternate floor mounting of the safety reversing sensor will require hardware not provided.
- Step 6, page 20 – Do you have a finished ceiling in your garage? If so, a support bracket and additional fastening hardware may be required.
- Step 12, page 24 – Do you have a steel, aluminum, fiberglass or glass panel door? If so, horizontal and vertical reinforcement is required.
- Look at the garage door where it meets the floor. **It must close on the floor all the way across. Otherwise, the safety reverse system may not work properly.** See page 30. Floor or door should be repaired.

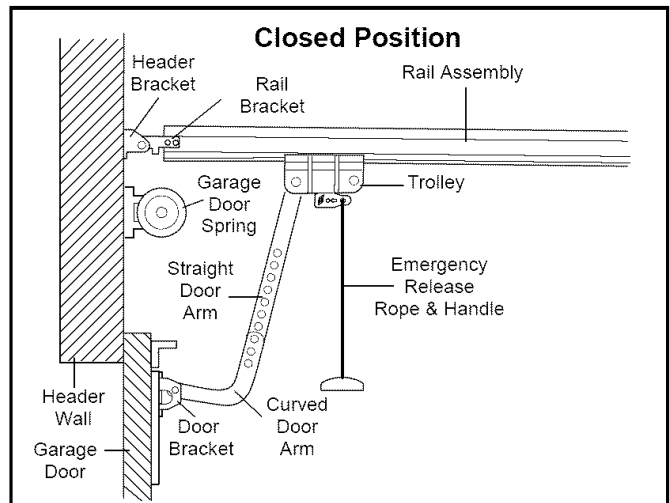

- The opener can be installed within 2 feet of the left or right of the door center if there is a torsion spring or center bearing plate in the way of the header bracket or door bracket area. *If your door has extension springs, the opener must be installed in the center of the door.* See pages 12 and 24.
- Do you have an access door in addition to the garage door? If not, Model 53702 Emergency Key Release is required. See page 38.
- If your door is more than 7 feet high, see the rail extension kits listed on page 38.

You may find it helpful to refer back to this page as you proceed with the installation of your opener.

# ONE-PIECE Door Installation

Before you begin, survey your garage area to see whether any of the conditions below apply to your installation.

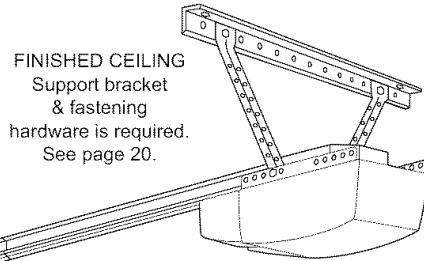

## One-Piece Door without Track

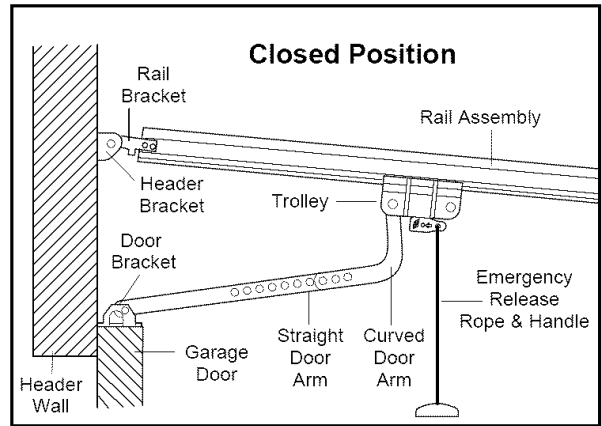
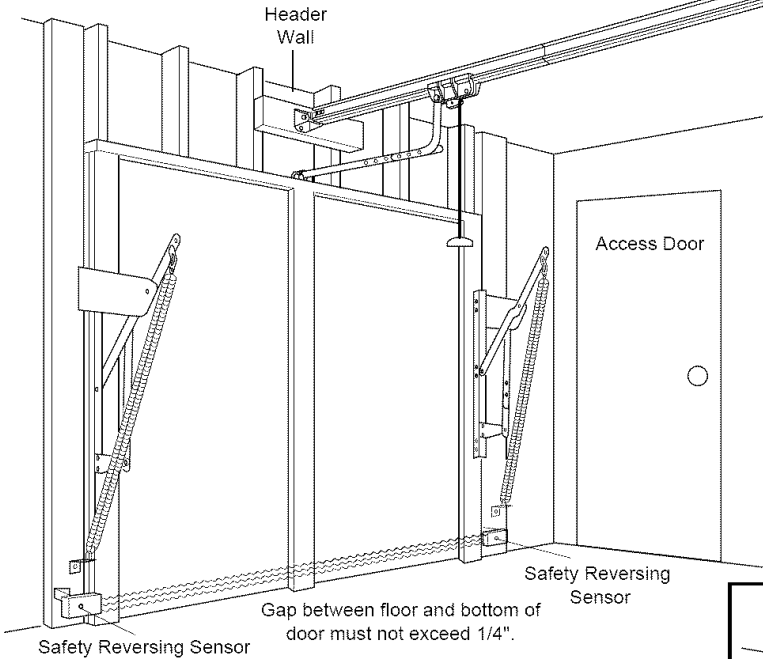

## One-Piece Door With Track

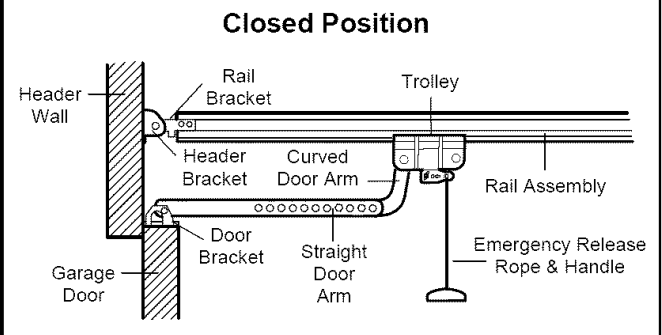
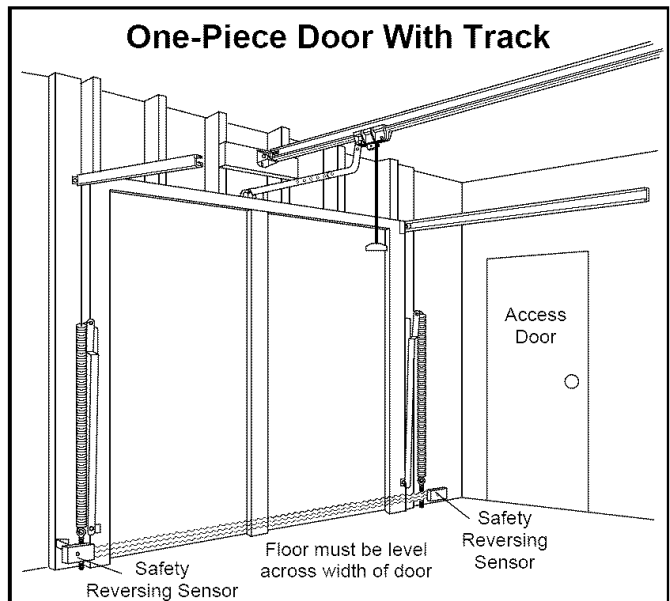

Based on your particular requirements, there are several installation steps which might call for materials and/or hardware not included in the carton.

- Step 1, page 13 – Look at the wall or ceiling above the garage door. The header bracket *must* be securely fastened to structural supports.
- Step 6, page 20 – Do you have a finished ceiling in your garage? If so, a support bracket and additional fastening hardware (not supplied) may be required.
- Safety reversing sensor, page 16 – Depending on garage construction, wood blocks may need to be securely fastened to mounting locations before sensors are installed.
- Step 14, page 17 – Alternate floor mounting of the safety reversing sensor will require hardware that is not provided.
- Step 12, page 25 – Generally, a one-piece door does not require reinforcement. If your door is lightweight, you can refer to the information relating to sectional doors on page 24.
- Step 12, page 25 – Depending on your door's construction, you might need additional mounting hardware for the door bracket.
- Do you have an access door in addition to the garage door? If not, Model 53702 Emergency Key Release is required. See page 38.
- **The gap between the bottom of the garage door and the floor cannot exceed 1/4". Otherwise, the safety reverse system may not work properly.** See page 30. The floor or the door should be repaired.

You may find it helpful to refer back to this page as you proceed with the installation of your opener.

## Assembly Step 1 Assemble the Rail

To avoid installation difficulties, do not run the garage door opener until instructed to do so.

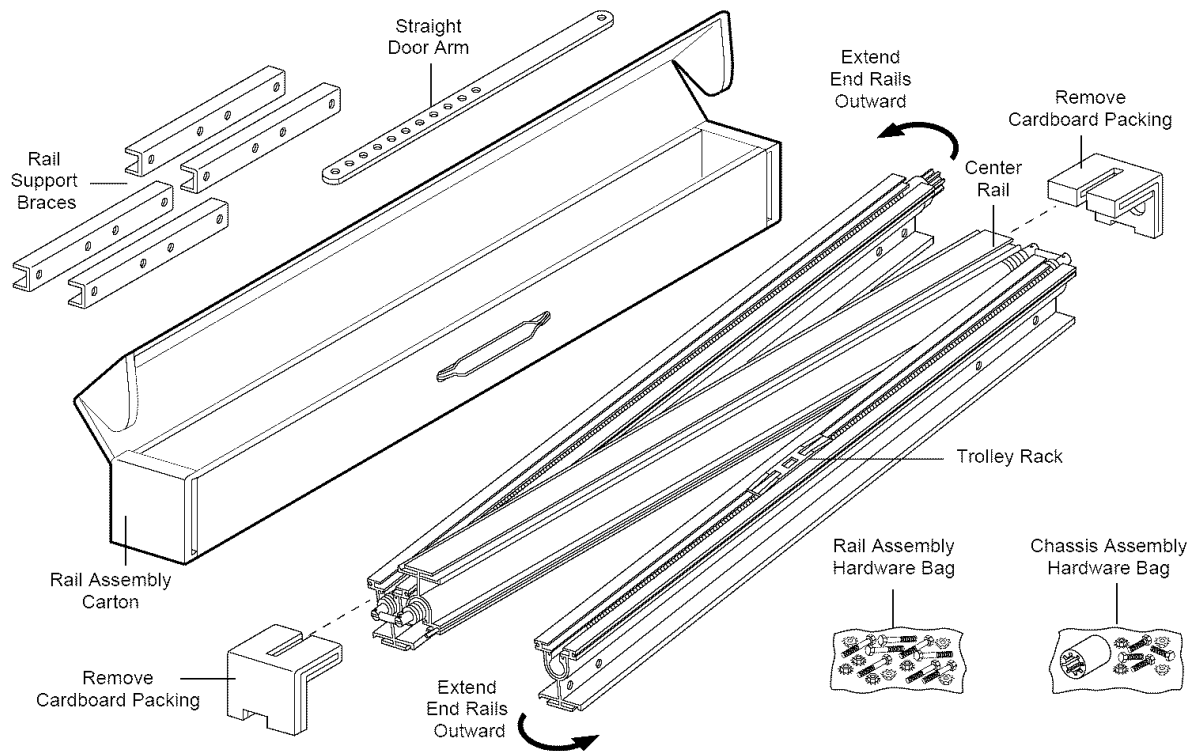

1. Turn the opened rail carton upside down, emptying its contents onto a level work surface.
2. Unfold the rails, taking care to avoid kinking the screw rod joints.
3. Rotate the rail sections so that the flat side is down and the screw side is up for all three lengths. Keep it clean and free of debris while you are working.

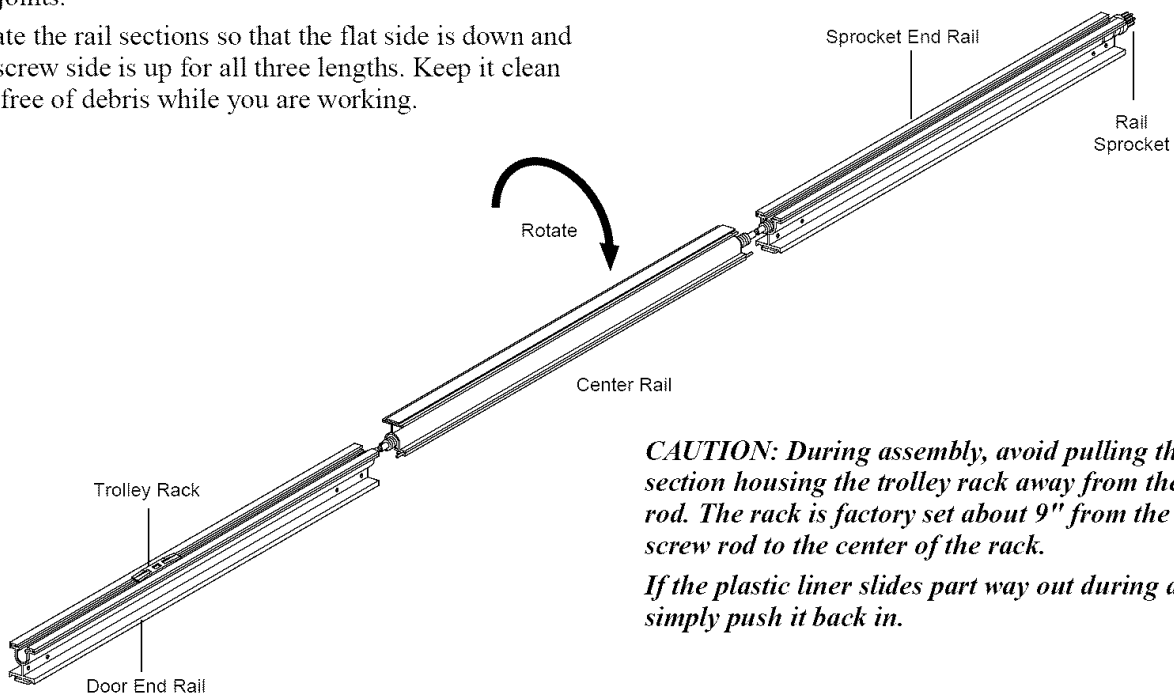

**CAUTION:** During assembly, avoid pulling the rail section housing the trolley rack away from the screw rod. The rack is factory set about 9" from the end of the screw rod to the center of the rack.

If the plastic liner slides part way out during assembly, simply push it back in.



# Assembly Step 1 (Continued)

## Assemble the Rail

- Beginning with the sprocket end, straighten the two rail sections so that the screw rod is in a straight line at the joint. (Avoid handling the joints, which may have sharp edges.)
- Carefully slide the pins at the top edge of the rail into the openings on the adjacent rail. ***It is essential that the rail assembly be on a level surface to achieve proper alignment and to avoid damage to the pins.***
- Insert two 1/4"-20x1-3/4" bolts through the *center* holes of a brace, and place its *open* length against the rail at this joint, aligning the holes as shown. Position another brace on the opposite side of the rail over the bolts, add 1/4"-20 lock nuts, and hand tighten. Insert two additional bolts and hand tighten.
- Keeping the rail straight and on a level surface, grasp the screw rods on each side of the remaining joint and pivot into a straight line. Repeat steps 5 and 6.
- With a 7/16 wrench, tighten bolts til snug, working from the center holes of the braces to those further from the joints. Do not overtighten.

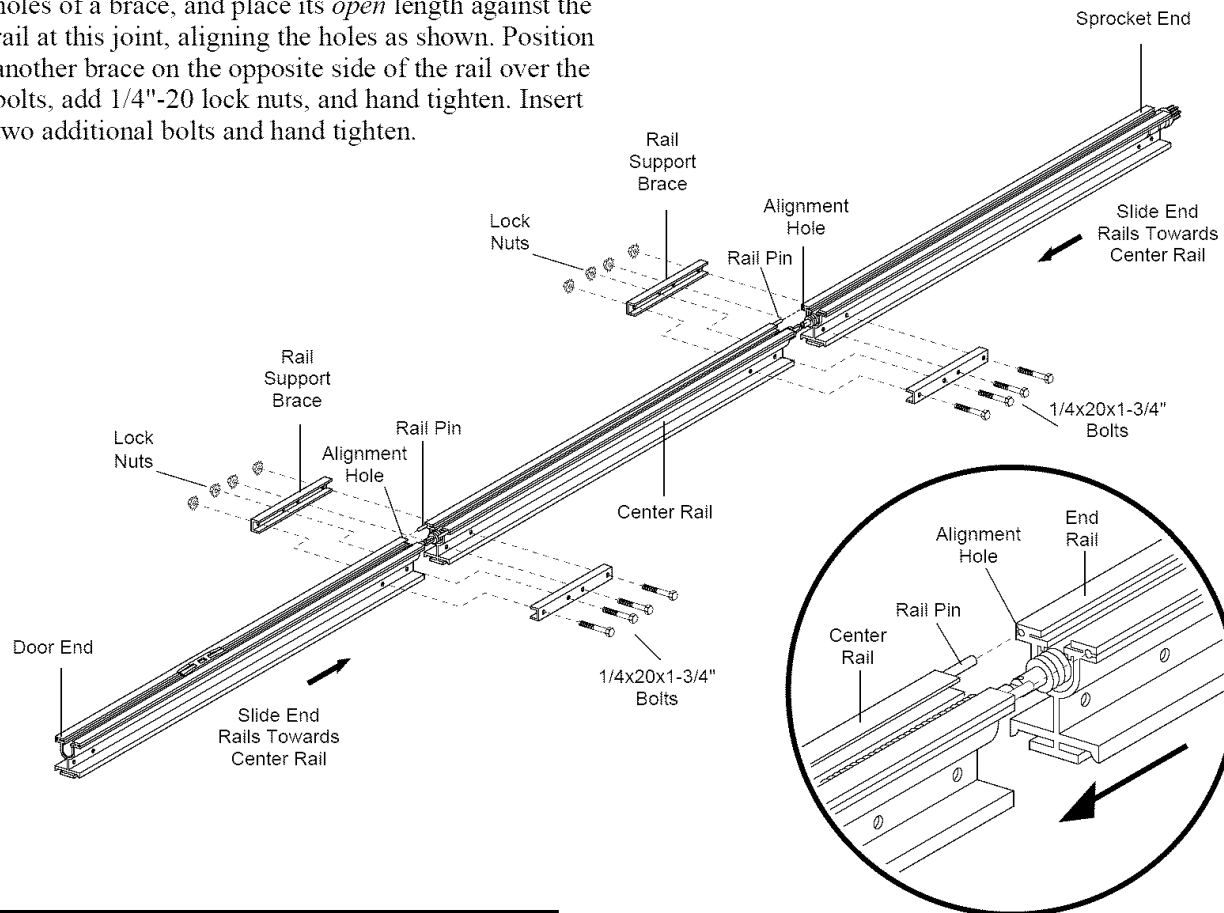

### Hardware Shown Actual Size

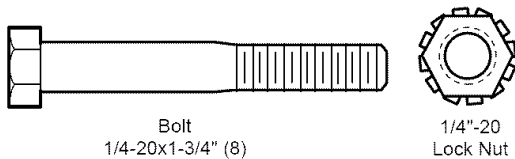

## Assembly Step 2

### Fasten the Rail To the Power Unit and Install the Trolley

**NOTE:** To aid in assembly and installation, replace the foam packing around the power unit. Remove it after Installation Step 5.

- Working on a level surface, align the rail assembly with the power unit, as shown.
- Slip the coupling over the rail sprocket.
- Slide the rail through the power unit bracket until the coupling fits securely over the power unit sprocket.
- Align the two screw holes in the rail with those in the power unit bracket. Insert two 1/4"-20x5/8" hex screws and lock nuts. Tighten securely with a 7/16" socket wrench.

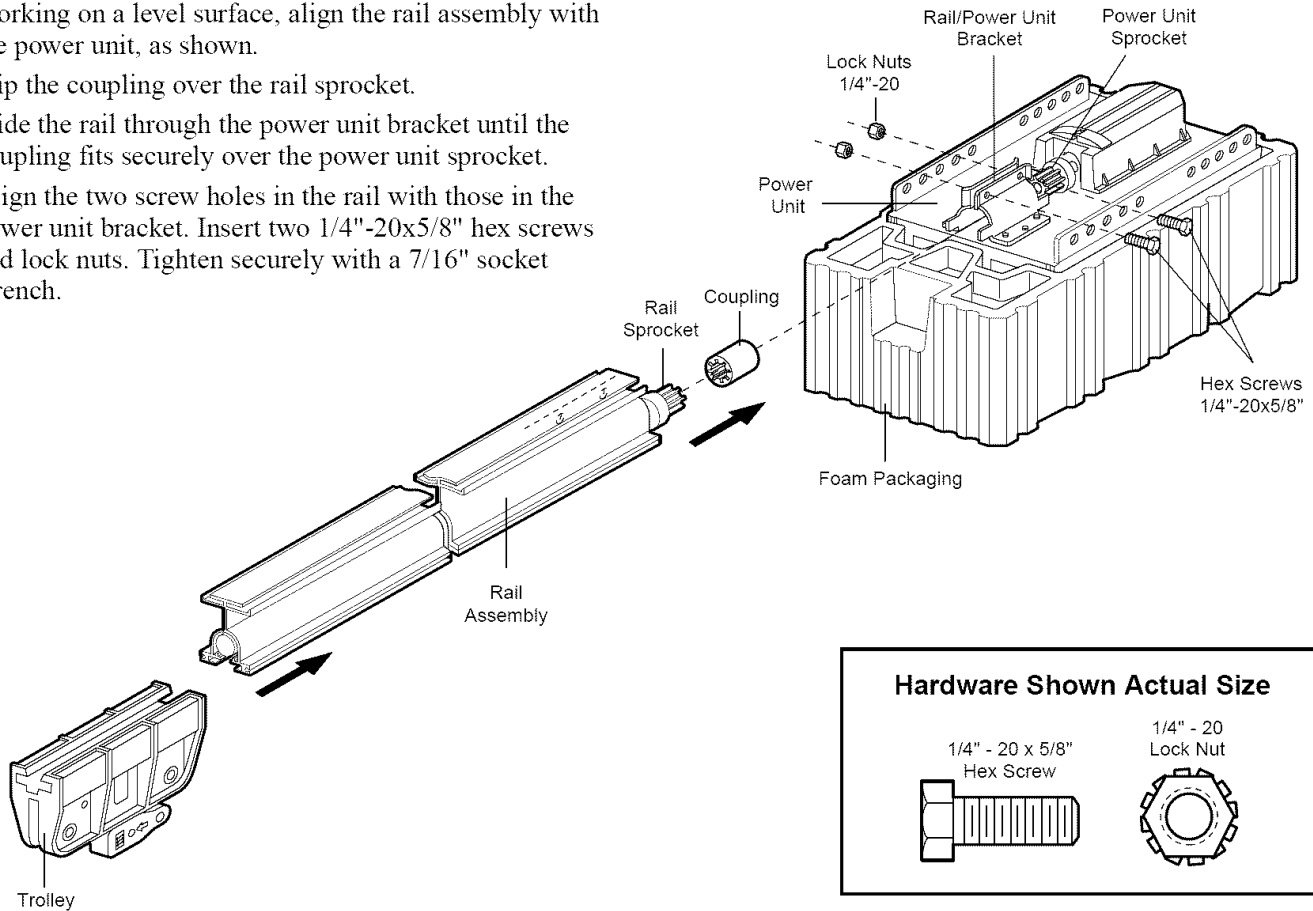

As illustrated above, slide the trolley onto and along the bottom of the rail until it snaps firmly in place. **Be certain to install it facing correctly: the trolley release arm must be horizontal (lock position), with its arrow pointed away from the power unit.**

## Assembly Step 3

### Attach the Rail Brackets

- Align rail brackets to end of rail assembly, as shown.
- Insert two 1/4"-20 x 5/8" hex screws and lock nuts. Tighten securely with a 7/16" socket.

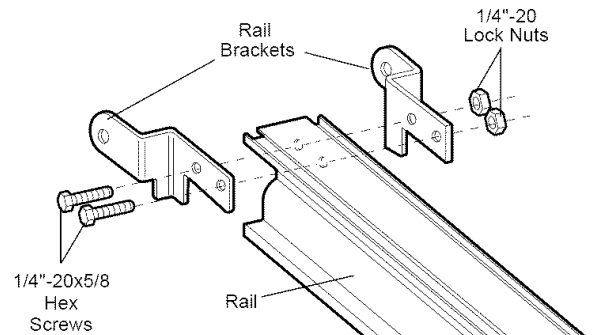
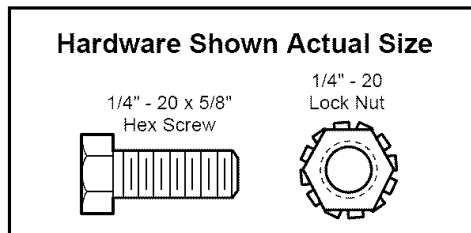

You have now finished assembling your garage door opener. Please read the following warnings before proceeding to the installation section:

## IMPORTANT INSTALLATION INSTRUCTIONS



**WARNING**



**WARNING**

**To reduce the risk of severe injury or death to persons:**

1. **READ AND FOLLOW ALL INSTALLATION INSTRUCTIONS**
2. Install only on a properly balanced and lubricated garage door. *An improperly balanced door may not reverse and could result in severe injury or death.* Repairs to cables, spring assemblies and other hardware must be made by a professional service person before installing opener.
3. Disable all locks and remove all ropes connected to the garage door before installing the opener. *Ropes connected to a garage door can cause entanglement and death.*
4. If possible, install door opener 7 feet or more above floor with the emergency release handle mounted 6 feet above the floor.
5. Do not connect the opener to power source until instructed to do so.
6. Locate the Door Control within sight of the door at a minimum height of 5 feet where small children cannot reach, and away from all moving parts of the door.
7. Install the User Safety Instruction Label on the wall adjacent to the control button and the Maintenance Instruction Label in a prominent location on the inside of the garage door.
8. Upon completion of the installation, the door must reverse when it comes in contact with a one-inch high object or a 2x4 laid flat on the floor.
9. Do not wear watches, rings or loose clothing while installing or servicing an opener. Jewelry or loose clothing can be caught in the mechanism of the garage door or the opener.

## Installation Step 1

### Determine Header Bracket Location

Installation procedures vary according to garage door types. Follow the instructions which apply to your door.



## WARNING

If the header bracket is not rigidly fastened to a structural support on the header wall or ceiling, the safety reverse system may not work properly (see page 30). *The door might not reverse when required, and could cause serious injury or death.*

The garage door springs, cables, pulleys, brackets and their hardware are under extreme tension. *Do not attempt to loosen, move or adjust them yourself. Serious personal injury or death could result. Call for professional garage door service.*

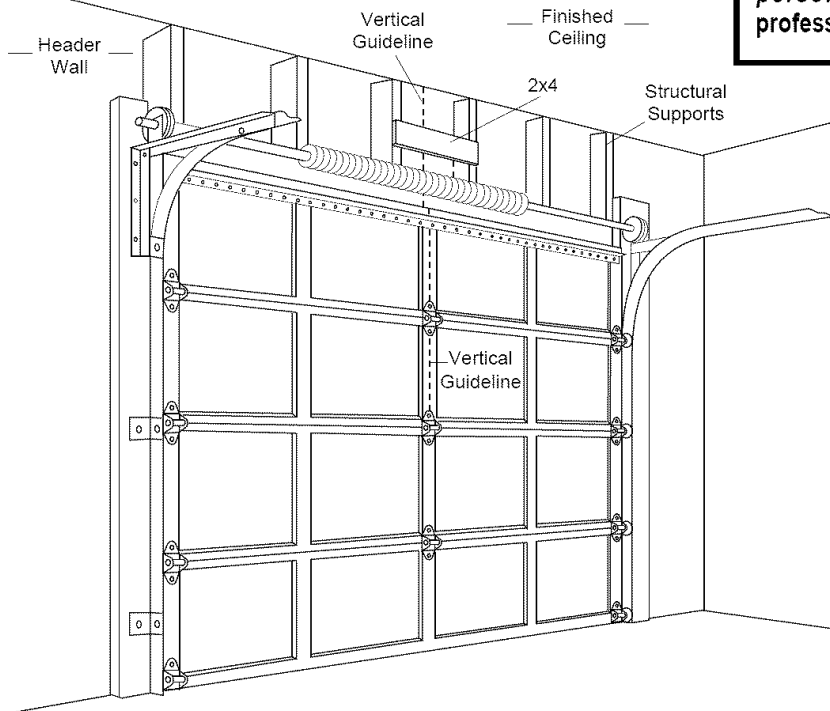

## SECTIONAL Door or ONE PIECE Door with Track

- Close the door and mark the inside vertical centerline of the garage door.
- Extend the line onto the header wall above the door.

**Remember, you can fasten the header bracket within 2 feet of the left or right of the door center *only* if a torsion spring or center bearing plate is in the way; or you can attach it to the ceiling (refer to page 14) when clearance is minimal. (It may be mounted on the wall upside down if necessary, to gain approximately 1/2".)**

*If you need to install the header bracket on a 2x4 (on wall or ceiling), use lag screws (not supplied) to securely fasten the 2x4 to structural supports as shown here and on page 13.*

- Open your door to the highest point of travel as shown. Draw an intersecting horizontal line on the header wall 3" above the high point. This height will provide travel clearance for the top edge of the door.
- Door clearance brackets are available for sectional doors when headroom clearance is less than 2". See accessory page 38.

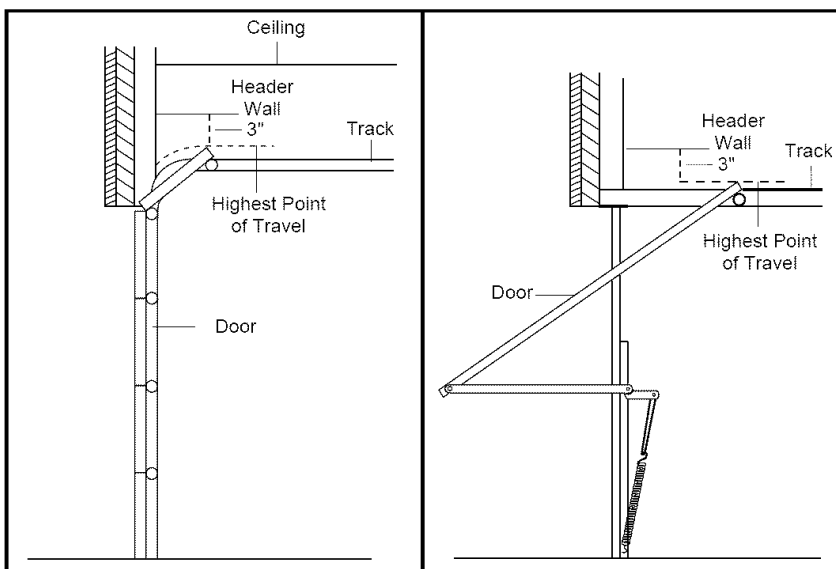

Sectional door with curved track

One-piece door with horizontal track

**Proceed to Step 2, page 14.**

# ONE-PIECE Door Without Track

Read the Safety Instructions on page 12. They also apply to doors without tracks.

- Close the door and mark the inside vertical centerline of your garage door. Extend the line onto the header wall above door.  
If headroom clearance is minimal, you can install the header bracket on the ceiling. See page 14.
- *If you need to install the header bracket on a 2x4 (on wall or ceiling), use lag screws (not supplied) to securely fasten the 2x4 to structural supports as shown.*

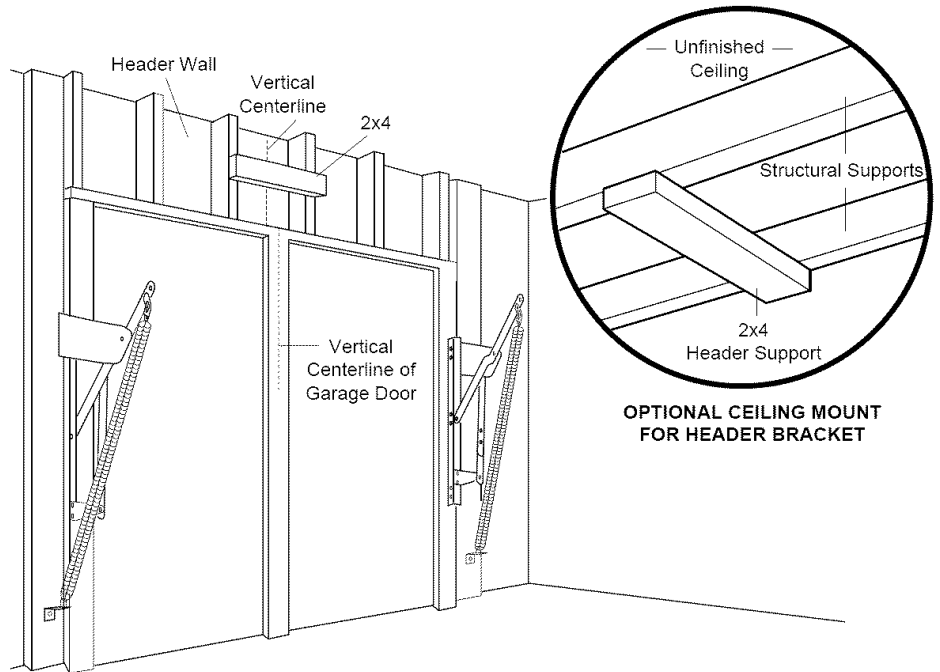

- Open your door to the highest point of travel as shown. Measure the distance from the top of the door to the floor. Subtract the actual height of the door. Add 8" to the remainder. (See Example).
  - Close the door and draw an intersecting horizontal line on the header wall at the determined height.
- If the total number of inches exceeds the height available in your garage, use the maximum height possible, or refer to page 14 for ceiling installation.**

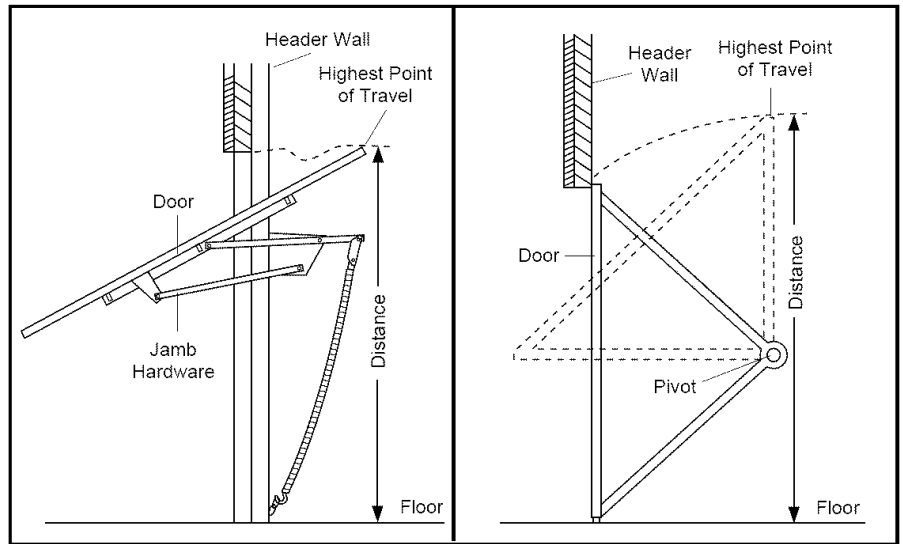

One-piece door without track jamb hardware

One-piece door without track pivot hardware

EXAMPLE	
Distance from top of door (at highest point of travel) to floor .....	.92"
Actual height of door .....	-88"
Remainder .....	.4"
Add .....	+8"
Bracket height on header wall .....	=12"
(Measure UP from top of CLOSED door.)	

# Installation Step 2

## Install the Header Bracket

You can attach the header bracket either to the wall above the garage door, or to the ceiling. Follow the instructions which will work best for your particular requirements.

### Fastening the Header Bracket to the Wall

- Center the bracket on the vertical guideline with the bottom edge of the bracket on the horizontal line as shown (with the arrow pointing toward the ceiling).
- Mark either set of bracket holes (do not use the holes designated for ceiling mount). Drill 3/16" pilot holes and fasten the bracket securely to a structural support with the hardware provided.

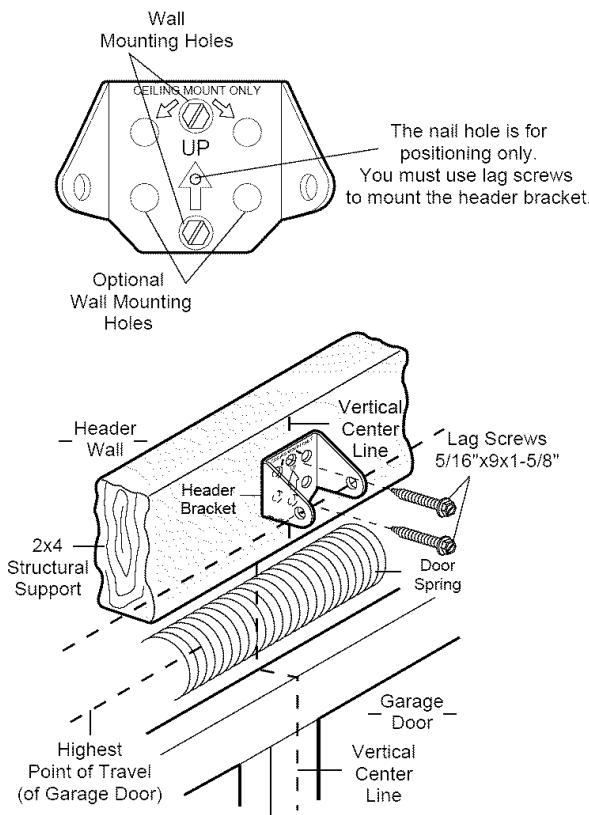

### Fastening the Header Bracket to the Ceiling

- Extend the vertical guideline onto the ceiling as shown.
- Center the bracket on the vertical mark, no more than 6" from the wall. Make sure the arrow is pointing toward the wall. The bracket can be mounted flush against the ceiling when clearance is minimal.
- Mark holes designated for ceiling mount only. Drill 3/16" pilot holes and fasten bracket securely to a structural support with the hardware provided.

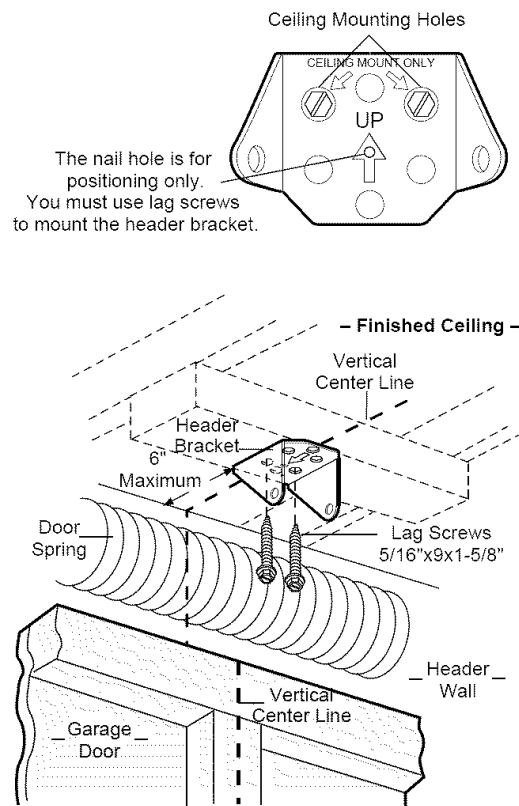

#### Hardware Shown Actual Size

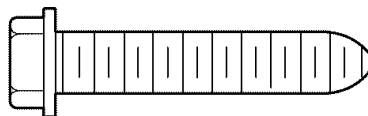

Lag Screw  
5/16"-9 x 1-5/8"

## Installation Step 3

### Attach the Rail to the Header Bracket

- Position the opener on the garage floor below the header bracket. Use packing material as a protective base.

**If the door spring is in the way you'll need help. Have someone hold the opener securely on a temporary support to allow the rail to clear the spring.**

- Position the rail bracket against the header bracket.
- Align the bracket holes and join with a clevis pin as shown.
- Insert a ring fastener to secure.

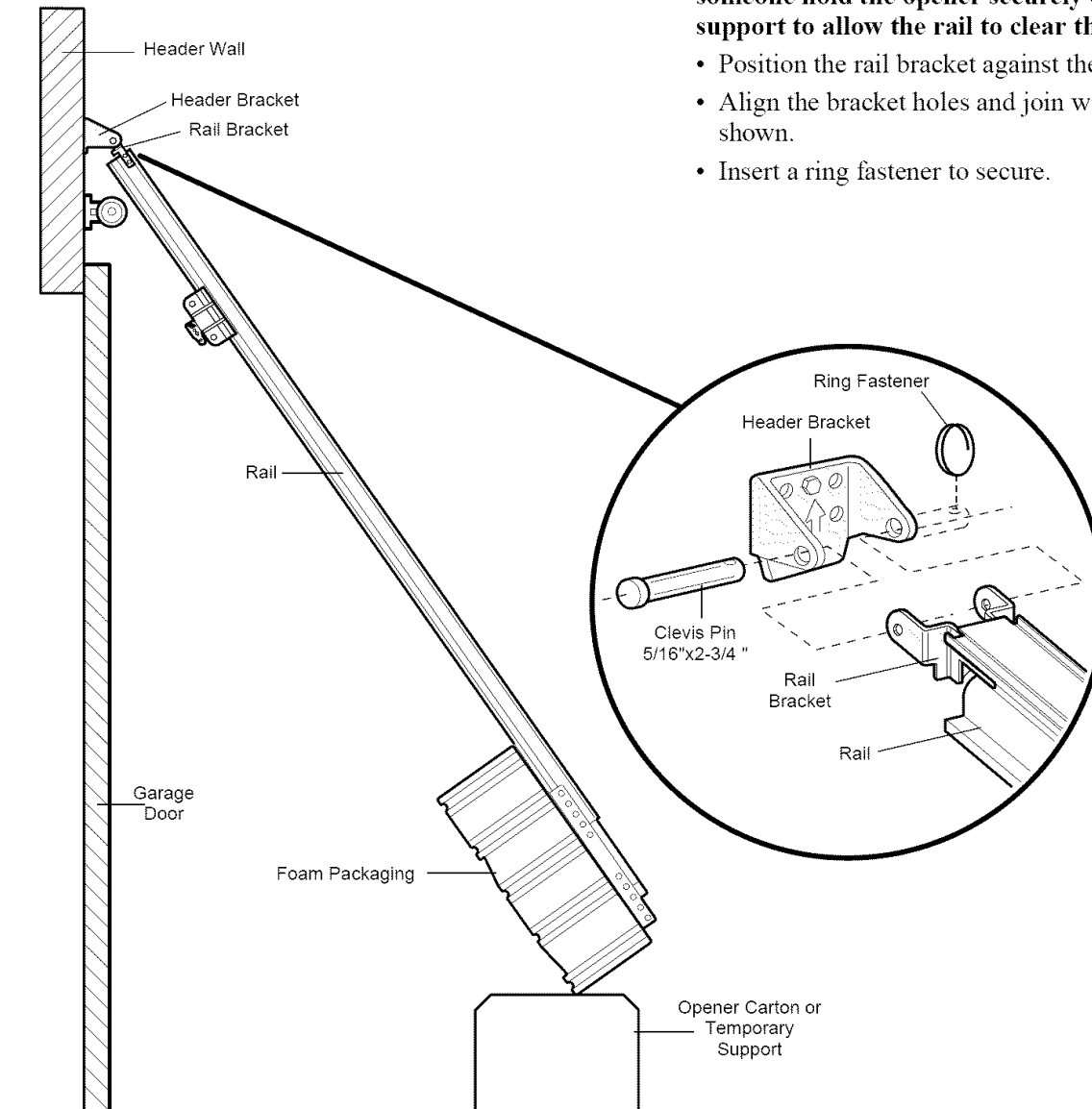

#### Hardware Shown Actual Size



Clevis Pin  
5/16" x 2-3/4"



Ring Fastener

# The Safety Reversing Sensor

## Information you'll need before you begin the installation of the safety reversing sensor

The safety reversing sensor *must* be connected and aligned correctly before the garage door opener will move in the down direction. This is a required safety device and cannot be disabled.

*Installation procedures are the same for sectional and one-piece doors.*

### Be sure power to the opener is disconnected.

The sending eye transmits an invisible light beam to the receiving eye. The units can be installed on either side of the garage door as long as the sun never shines directly into the receiving eye lens.

Look at the label on the connector end of each case to identify the sensors.

The brackets must be connected and fastened so that the sending and receiving eyes face each other as shown.

If an obstruction breaks the light beam while the garage door is closing, the door will stop and reverse to full open position and the opener lights will flash for 5 seconds.

The brackets *must* be securely fastened to a solid surface such as the studs on either side of the door, or add a piece of wood at each location if installing in masonry construction.

**WARNING**

*Without a properly working safety reversing sensor, persons (particularly children) could be injured or killed by a closing garage door. Read and follow all instructions.*

**To protect small children, install the safety reversing sensor so that the beam will be no higher than 4"-6" above the garage floor.**

**Disconnect power to the garage door opener before installing the safety reversing sensor.**

The invisible light beam path must be unobstructed. No part of the garage door (or door tracks, springs, hinges, rollers or other hardware) can interrupt the beam while the door is closing. If it does, use a piece of wood to build out each sensor mounting location to the minimum depth required for light beam clearance.

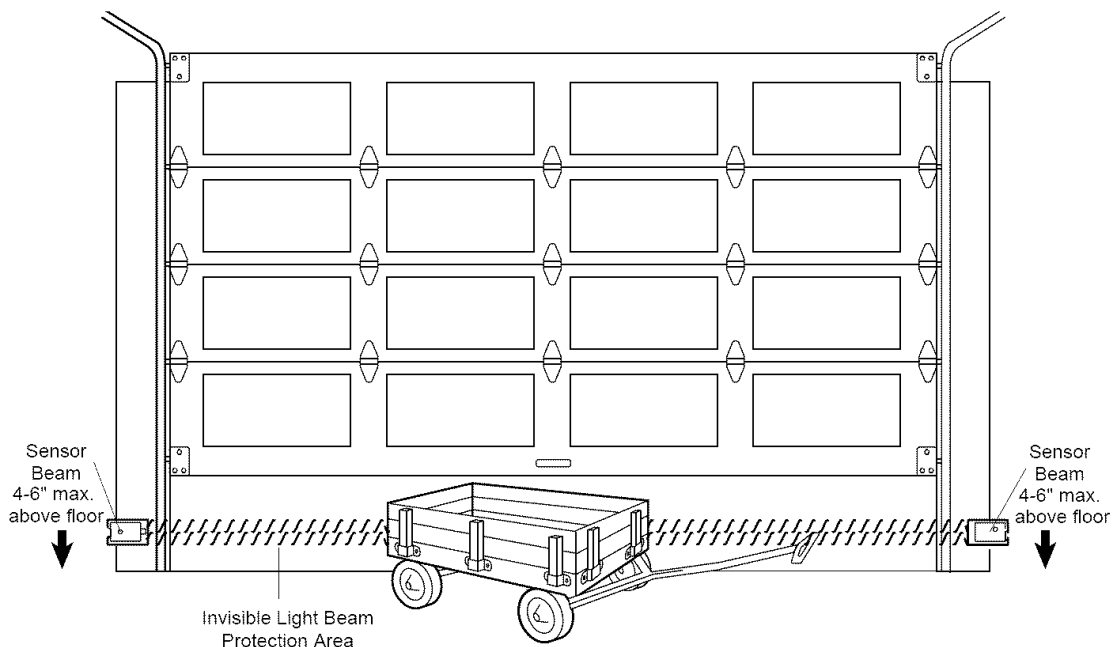

**Facing the door from inside the garage**



# Installation Step 4

## Install the Safety Reversing Sensor (Receiving and Sending Eyes)

Figures 1 and 2 show assembly of brackets and "C" wrap based on the recommended installation of the sensors on each side of the garage door as shown on page 16.

However, Figures 3 and 4 are variations which may fit your installation requirements better. **Make sure the wraps and brackets are aligned so the sensors will face each other across the garage door.**

1. Fasten the "C" wraps to the mounting brackets having square holes, using the hardware shown in Figure 3.
2. Connect each assembly to a slotted bracket, using the hardware shown in Figure 2.

**Note the alignment of the brackets for left and right sides of the door.**

3. Finger tighten the lock nuts.
4. Use bracket mounting holes as a template to locate and drill (2) 3/16" diameter pilot holes on both sides of the garage door, 4"-6" above the floor **but not exceeding 6"**. (See warning on page 16.)
5. Attach bracket assemblies with 1/4"x1-1/2" lag screws as shown in Figure 2.
6. Adjust right and left side bracket assemblies to the same distance out from the mounting surface. Make sure all door hardware obstructions are cleared. Tighten the nuts securely.

Figure 1

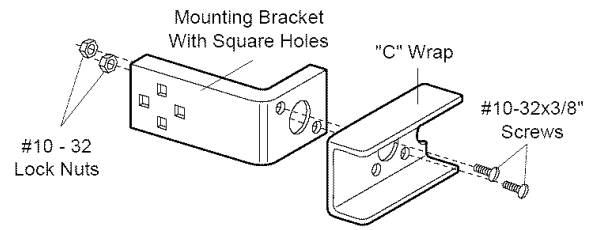

Figure 2

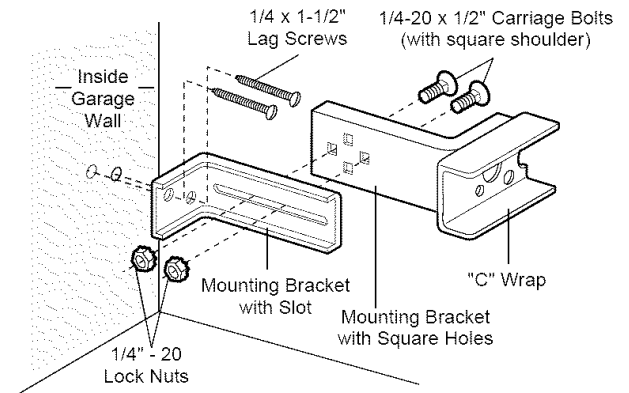

Figure 3

Alternate Wall Mount

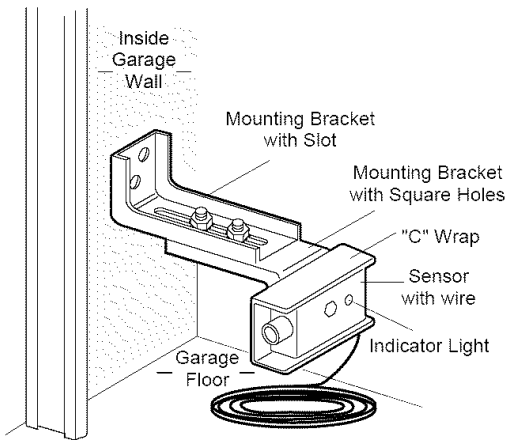
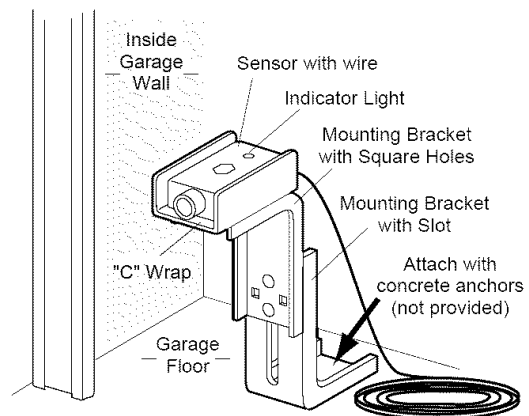

Figure 4

Alternate Floor Mount



### Hardware Shown Actual Size



#10 - 32 x 3/8" Screw



#10 x 32 Lock Nut

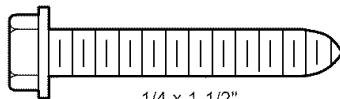

1/4 x 1-1/2" Lag Screw

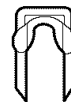

Staples

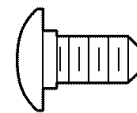

1/4" - 20 x 1/2" Carriage Bolts

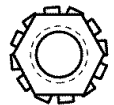

1/4" - 20 Lock Nut

## Installation Step 4 (Continued)

### Install the Safety Reversing Sensor

- Center each sensor unit in a "C"- wrap with lenses pointing toward each other across the door (see Figure 5).
- Secure sensors with the hardware shown. Finger tighten the wing nut on the *receiving eye* to allow for final adjustment. Securely tighten the *sending eye* wing nut.

#### Recommended Wire Routing

- Using insulated staples, run the wires from both sensors to the rail at the door header (see Figure 6).
- Cross and twist the two wires where they meet the rail (see inset A). Run the wires inside the channels at the *top* of the rail, along each side, to the power unit and pull taut (see inset B). *Do not use the lower (trolley) channels.*

**NOTE: If your access door is near the garage door, you may choose to install the door control at this time and run the door control wire along the rail with the sensor wires. Use one rail channel for the door control wire and the other channel for both sensor wires. If you choose this option, follow instructions 1-3 on page 21 now.**

- Thread the wires through the tabs on top of the drive shaft cover.
- With your screwdriver tip, tuck the wires snugly into the rail channels. You will complete the wiring in Installation Step 7.

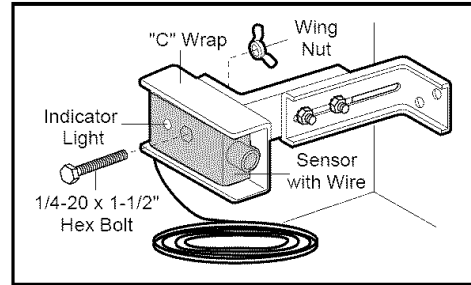

Figure 5

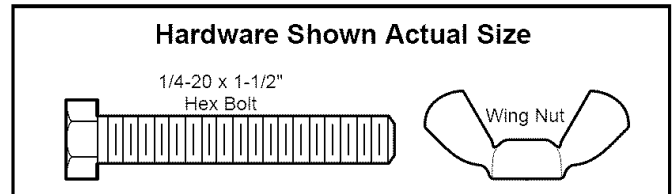
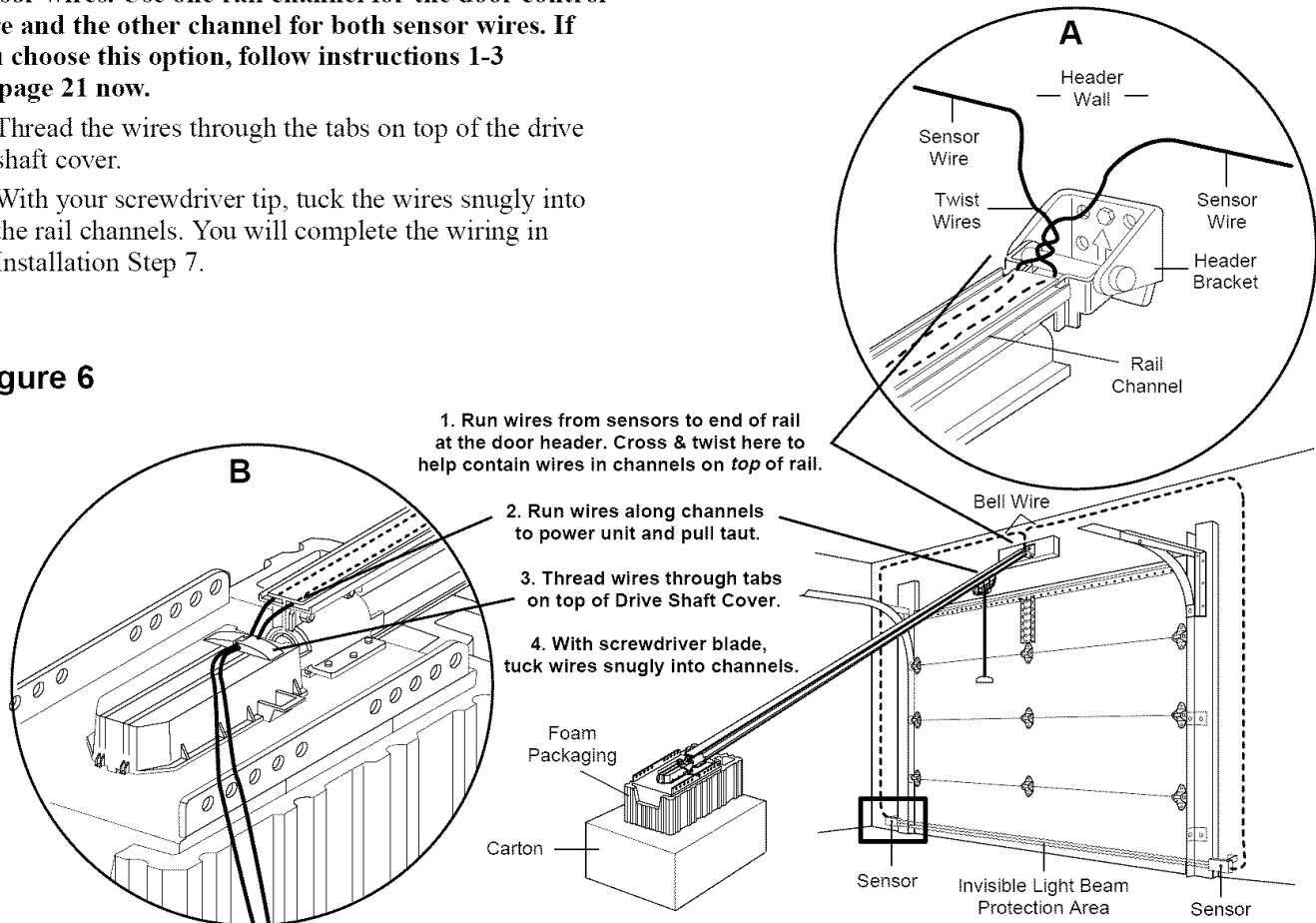

Figure 6



## Installation Step 5

### Position the Opener

Follow instructions which apply to your door type as illustrated.



## CAUTION

To prevent damage to steel, aluminum, fiberglass or glass panel doors, do not rest the opener on the door without using a 2x4.

### SECTIONAL Door or ONE-PIECE Door with Track

A 2x4 laid flat is convenient for setting an ideal door-to-rail distance.

- Raise the opener onto a stepladder.

*You will need help at this point if the ladder is not tall enough.*

- Open the door all the way and place a 2x4 laid flat on the top section beneath the rail.

*If the top panel hits the trolley when you raise the door, pull down on the trolley release arm to disconnect the inner and outer sections. The trolley can remain disconnected until Step 13 is completed.*

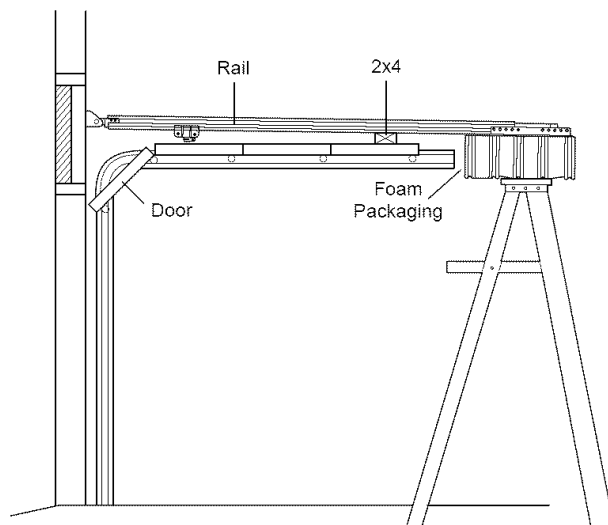
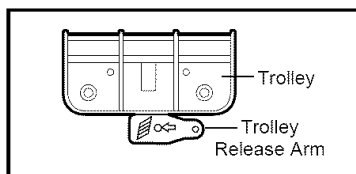

### ONE-PIECE Door without Track

- With the door fully open and parallel to the floor, measure the distance from the floor to the top of the door.
- Using a stepladder as a support, raise the opener to the same distance as the door from the floor (it will be at a slight angle as shown).
- The top of the door should be level with the top of the opener. Do not position the opener more than 3" above this point.

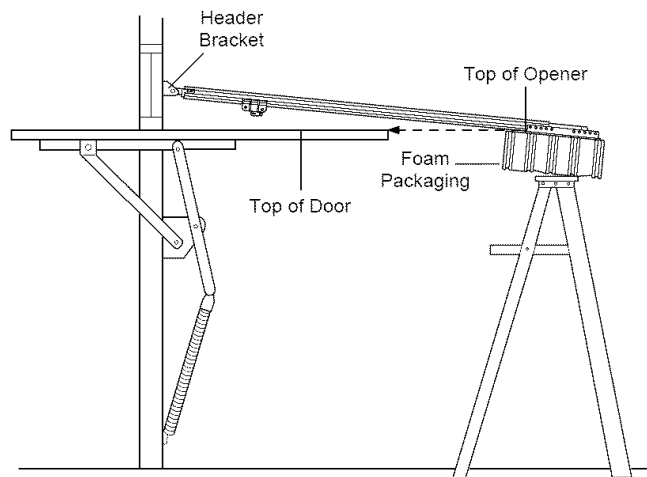

## Installation Step 6

### Hang the Opener

Two representative installations are shown. Yours may be different. Hanging brackets should be angled, Figure 1, to provide rigid support. On finished ceilings, Figure 2, attach a sturdy metal bracket to structural supports before installing the opener. *The bracket and fastening hardware are not supplied.*

1. Measure the distance from each side of the opener to the structural support.
2. Cut both pieces of the hanging bracket to required lengths.
3. Drill 3/16" pilot holes in the structural supports.
4. Attach one end of each bracket to a support with 5/16" - 18x1-7/8" lag screws.
5. Fasten the opener to the hanging brackets with 5/16" - 18x7/8" screws, lock washers and nuts.
6. Check to make sure the rail is centered over the door (or in line with the header bracket if the bracket is not centered above the door).
7. Remove the 2x4. Operate the door manually. If the door hits the rail, raise the header bracket.

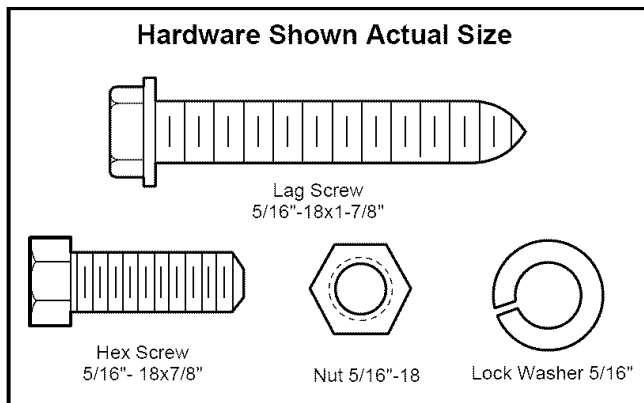

## WARNING

*The opener could fall and injure someone if it is not properly secured. Fasten the opener securely to structural supports of the garage.*

Figure 1

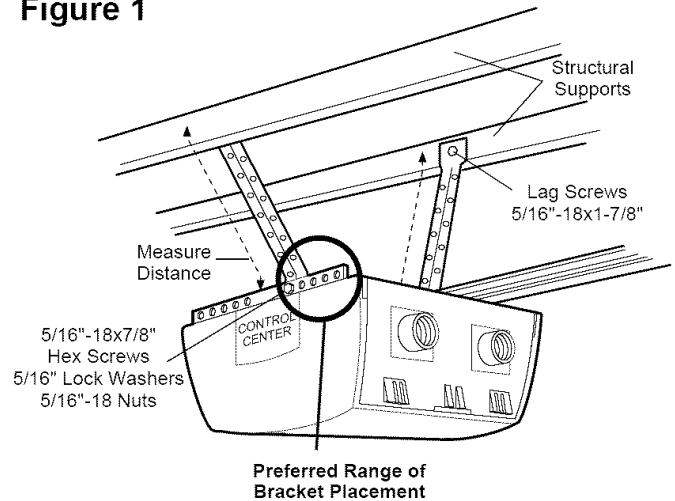
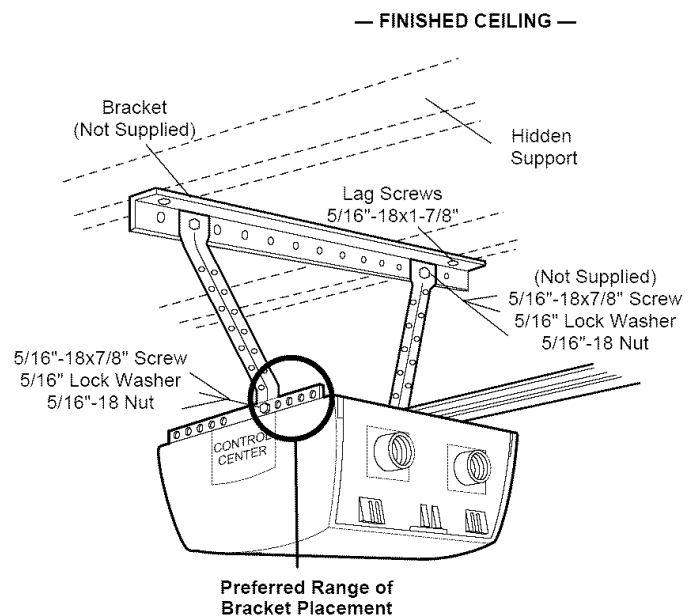

Figure 2



## Installation Step 7

### Install the Premium Control Console and Connect all Wiring

Locate the door control within sight of the door at a minimum height of 5 feet where small children cannot reach, and away from all moving parts of the door and door hardware.

The door control is typically attached directly to the wall. If installing into drywall, drill 5/32" holes and use the anchors provided. For pre-wired installations (as in new home construction), Console models may be mounted to a standard single gang box (Figure 2).

- Strip 1/4" of insulation from one end of the bell wire and connect it to the two screw terminals on the back of the door control by color: white to 2 and white/red to 1.
- Pry off cover along one side with a screwdriver blade (see Figure 1). Fasten with 6ABx1-1/4" self-tapping screws (standard installation) or 6-32x1" machine screws (pre-wired installation) as follows:
  - Install bottom screw, allowing 1/8" to protrude above wall surface.
  - Position bottom of door control on screw head and slide down to secure. Adjust screw for snug fit.
  - Drill and install top screw with care to avoid cracking plastic housing. Do not overtighten.
  - Insert top tabs and snap on cover.
- (For standard installation only) Run the bell wire up the wall and across the ceiling to the opener. Use insulated staples to secure the wire in several places. Be careful not to pierce the wire with a staple, creating a short. If your access door is near the garage door, you may run this wire with the Safety Reversing Sensor wires along the top of the rail. See page 18.
- Remove the Control Center door on the right panel of the opener to access the terminal screws.
- Thread all wires through the opening at the base of the drive shaft cover (see Figure 3).
- Insert the remaining wire through the hole in the power unit and strip 1/4" of insulation from each set of wires.
- Connect the door control wire to the opener terminal screws: white to 2 and white/red to 1. (See Figure 4.)
- Separate the sensor white and white/black wires sufficiently to connect to the opener terminal screws: white to 2 and white/black to 3.
- Attach the User Safety Instruction label to the wall near the door control, and the Maintenance Instruction label in a prominent location on the inside of the garage door.

Page 32 explains how to operate the opener using the door control.

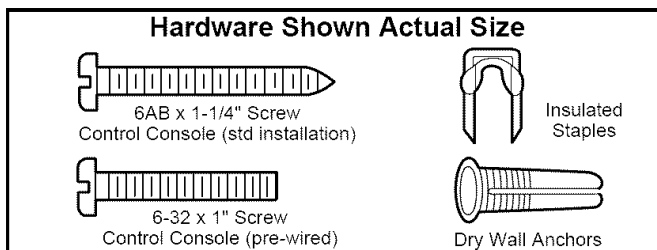

## WARNING

Do not connect to live electrical wiring. Connect only to 24 Volt low voltage wires. Connection to live wires or higher voltage may cause serious injury from shock, burn or electrocution.

Children operating or playing with a garage door opener can injure themselves or others. The garage door could close and cause serious injury or death.

Install the door control (or any additional push buttons) out of the reach of children and away from all moving parts of the door and door hardware, but where the garage door is visible. Do not allow children to operate the push button(s) or the remote control(s).

A moving garage door could injure someone under it. Activate the opener only when the door is properly adjusted, you can see it clearly, and there are no obstructions to door travel.

Do NOT connect the power and operate the opener at this time. See Step 9 on page 22.

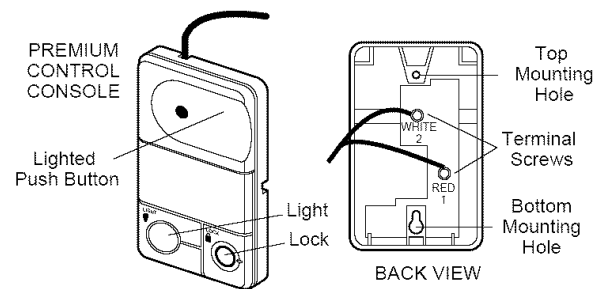

Figure 1

REMOVE & REPLACE COVER

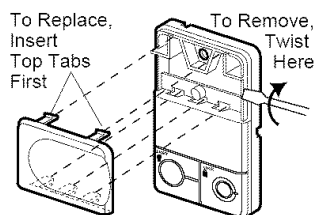

Figure 2

PRE-WIRED INSTALLATION

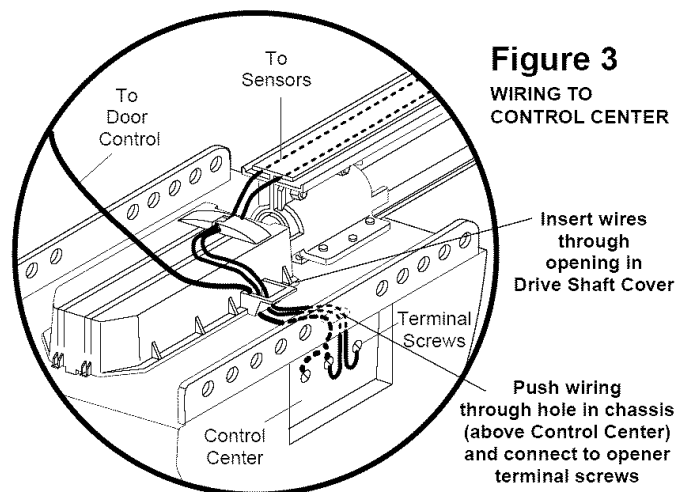
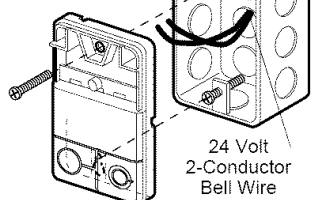

Figure 3

WIRING TO CONTROL CENTER

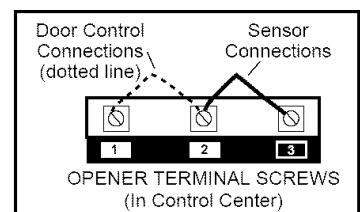

Figure 4

## Installation Step 8

### Electrical Requirements

To reduce the risk of electric shock, your garage door opener has a grounding type plug with a third grounding pin. This plug will *only* fit into a grounding type outlet. If the plug doesn't fit into the outlet you have, contact a qualified electrician to install the proper outlet.

*To avoid installation difficulties, do not run the opener until Step 9 below.*

If permanent wiring is required by your local code, refer to the following procedure:



**To prevent electrocution**, remove power from the garage door opener *and* from the circuit you plan to use for the permanent connection.

To make a permanent connection through the 7/8" diam. hole in the top of the opener (according to local code):

- Remove the opener cover screws and set the cover aside.
- Remove the attached 3-prong cord.
- Connect the black (line) wire to the screw on the brass terminal; the white (neutral) wire to the screw on the silver terminal; and the ground wire to the green ground screw. *The opener must be grounded.*
- Reinstall the cover.

## Installation Step 9

### Complete Safety Reversing Sensor Installation

#### Aligning the Safety Sensors

- Plug in the opener. Green indicator lights in both the sending and receiving eyes will *glow steadily* if wiring connections and alignment are correct.

The sending eye indicator light will glow regardless of alignment or obstruction. If the indicator light is off, dim, or flickering in the *receiving eye* (and the invisible light beam path is not obstructed), alignment is required.

- Loosen the *sending* eye wing nut and readjust, aiming directly at the receiving eye. Lock in place.
- Loosen the *receiving* eye wing nut and adjust sensor vertically and/or horizontally until it receives the sender's beam. When the green indicator light *glows steadily*, tighten the wing nut.



## WARNING

To prevent electrocution or fire, installation and wiring must be in compliance with local electrical and building codes.

Do **NOT** use an extension cord, 2-wire adapter, or change the plug in any way to make it fit your outlet.

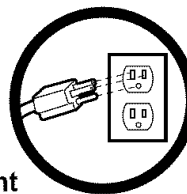

Right

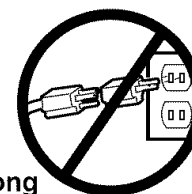

Wrong

#### Permanent Wiring Connection

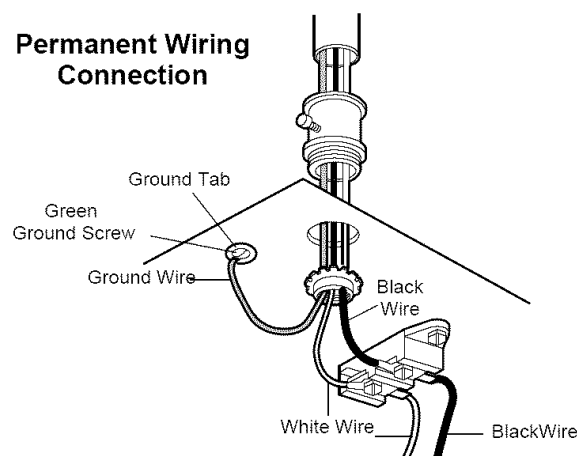

#### Trouble Shooting

1. If the *sending eye* indicator light does not *glow steadily* after installation, check for:
  - Electric power to the opener.
  - A short in the white or white/black wires. These can occur under staples or at screw terminal connections.
  - Incorrect wiring between sensors and opener.
  - An open wire (wire break).
2. If the sending eye indicator light *glows steadily* but the receiving eye indicator light doesn't:
  - Check alignment.
  - Check for an open wire to the receiving eye.
3. If the receiving eye indicator light is dim, realign either sensor.

**NOTE:** When the invisible beam path is obstructed or misaligned while the door is closing, the door will reverse. If the door is already open, it will not close. The opener lights will flash 10 times. (If bulbs are not installed, 10 clicks are audible.) See page 16.

## Installation Step 10

### Install the Lights and Lens

- Install a 100 watt maximum light bulb in each socket. The lights will turn ON and remain lit for approximately 4-1/2 minutes when power is connected. Then the lights will turn OFF.
- Insert bottom lens tabs into slots on chassis and tilt towards chassis to engage top tabs, then drop down gently into place. (See illustration.)
- To remove, lift lens up and *gently* tilt slightly outward and down, then pull out to clear bulbs. **Use care to avoid snapping off bottom lens tabs.**
- If the bulbs burn out prematurely, replace with *standard neck* Garage Door Opener bulbs. (Fluorescent bulbs are not recommended because of possible interference with receiver/transmitter signals.)

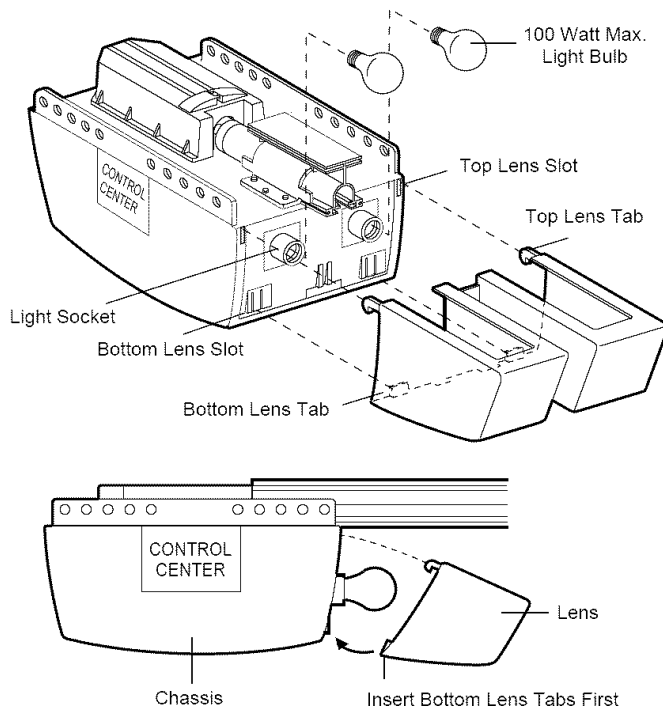

## Installation Step 11

### Attach the Emergency Release Rope and Handle

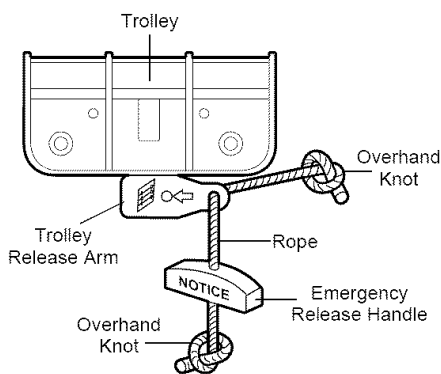

## WARNING

Do not use the red handle to pull the door open or closed. *The rope knot could become untied and you could fall.* Use the emergency release only to disengage the trolley and, if possible, only when the door is closed.

Garage doors are heavy. If the door is open when the handle is pulled, the door could close inadvertently if it is not properly balanced. Serious injury may result to persons under the door. Make sure the doorway is clear of persons and obstructions before pulling handle when door is open.

- Thread one end of the rope through the hole in the top of the red handle so "NOTICE" reads right side up as shown. Secure with an overhand knot.
- The knot should be at least 1" from the end of the rope to prevent slipping.**
- Thread the other end of the rope through the hole in the release arm of the outer trolley.
  - Adjust rope length so the handle is 6 feet above the floor. Secure with an overhand knot .
- If it is necessary to cut the rope, heat seal the cut end with a match or lighter to prevent unraveling.**

## Installation Step 12

### Fasten Door Bracket

Follow instructions which apply to your door type as illustrated below or on page 25.



## CAUTION

To prevent damage to steel, aluminum, fiberglass or glass panel doors, always reinforce the inside of the door both vertically and horizontally with an angle iron.

A horizontal brace should be long enough to be secured to 2 vertical supports. A vertical brace should cover the height of the top panel.

The illustration shows one piece of angle iron as the horizontal brace. For the vertical brace, 2 pieces of angle iron are used to create a U-shaped support. The best solution is to check with your garage door manufacturer for an opener installation door reinforcement kit.

## SECTIONAL Door Installation Procedure

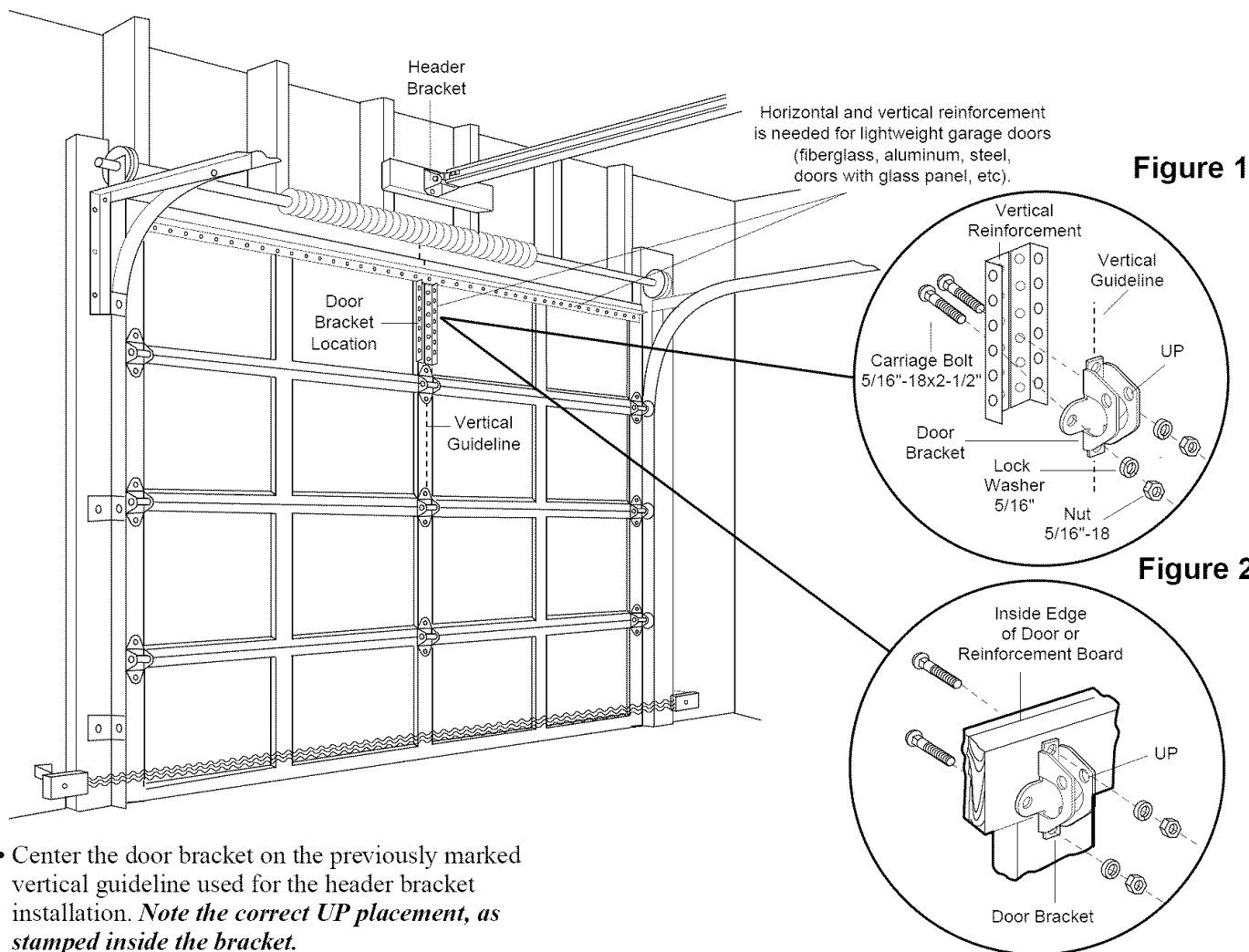

- Center the door bracket on the previously marked vertical guideline used for the header bracket installation. **Note the correct UP placement, as stamped inside the bracket.**
- Position the bracket on the face of the door within the following limits:
  - A) The top edge of the bracket 2-4" below the top edge of the door.
  - B) The top edge of the bracket directly below any structural support across the top of the door.
- Mark and drill 5/16" left and right fastening holes. Secure the bracket as shown in Figure 1 if there is vertical reinforcement.

If your installation doesn't require vertical reinforcement but does need top and bottom fastening holes for the door bracket, fasten as shown in Figure 2.

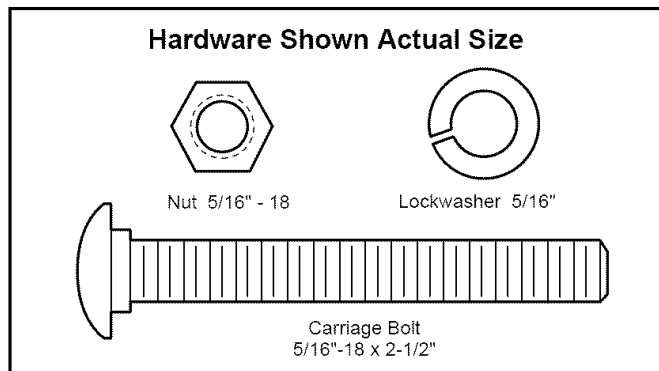



# All ONE-PIECE Door Installation Procedure

Please read and comply with the warnings and reinforcement instructions on page 24. They apply to one-piece doors also.

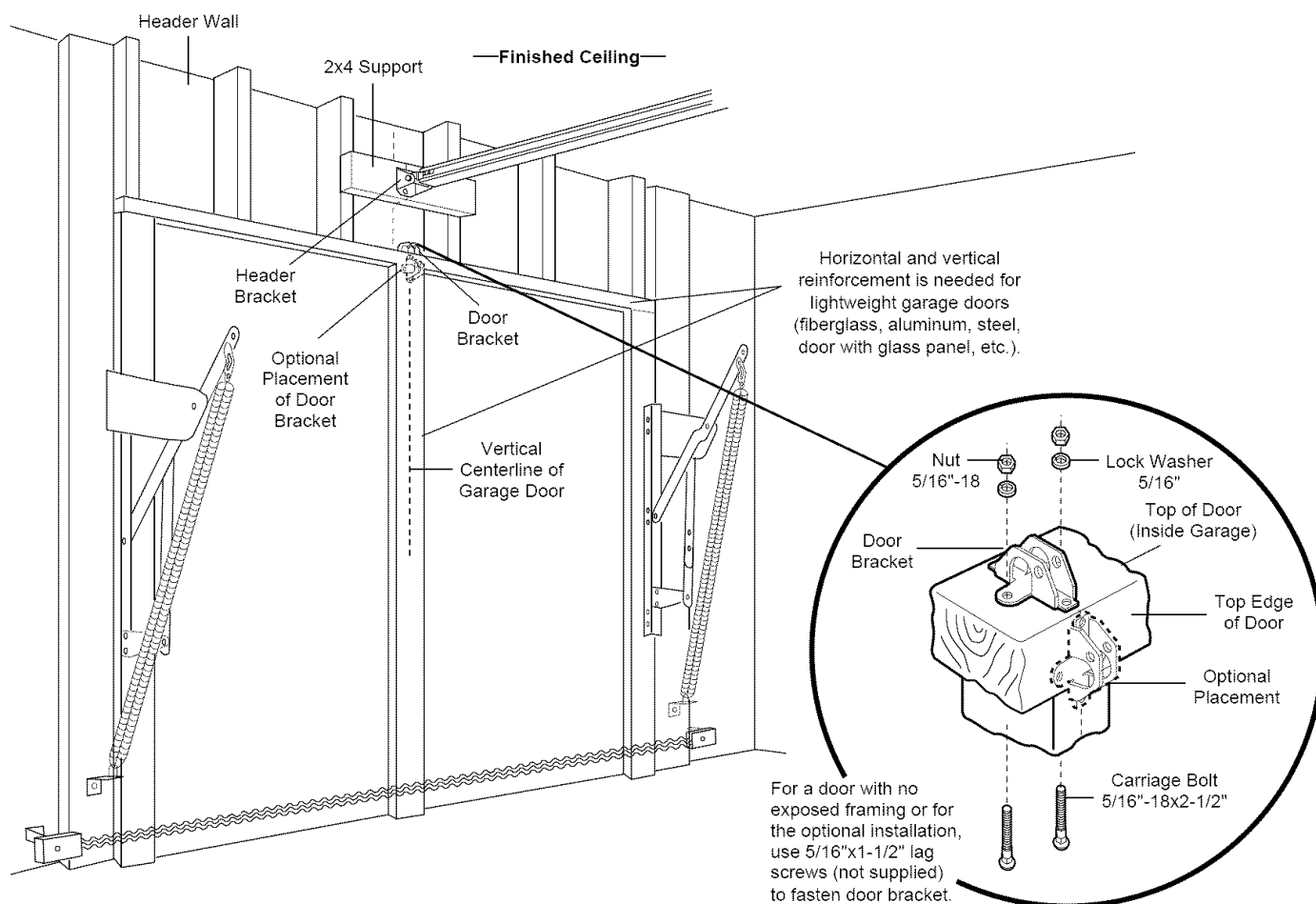

- Center the bracket on the top of the door, in line with the header bracket as shown. Mark holes.
- Drill 5/16" pilot holes and fasten the door bracket with hardware supplied.

If the door has no exposed framing, drill 3/16" pilot holes and fasten the bracket with 5/16"x1-1/2" lag screws (not supplied) to the top of the door.

**The door bracket may be installed on the top edge of the door if required for your installation. (Refer to the dotted line optional placement drawing.) Drill 3/16" pilot holes and substitute 5/16"x1-1/2" lag screws (not supplied) to fasten the bracket to the door.**

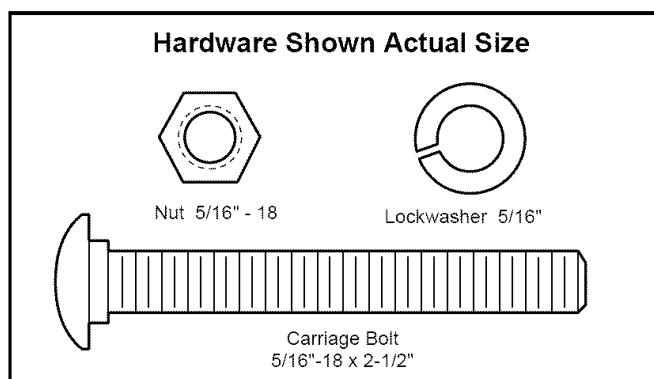

# Installation Step 13

## Connect Door Arm to Trolley

Follow instructions which apply to your door type as illustrated below and on page 27.

### SECTIONAL Doors Only

Make sure garage door is fully closed. Pull the emergency release handle to disconnect the outer trolley from the inner trolley. Slide the outer trolley back (away from the door) about 2" as shown in Figures 1, 2 and 3.

Figure 1:

- Fasten straight door arm section to outer trolley with the 5/16"x1" clevis pin. Secure the connection with a ring fastener.
- Fasten curved section to the door bracket in the same way, using the 5/16"x1-1/4" clevis pin.

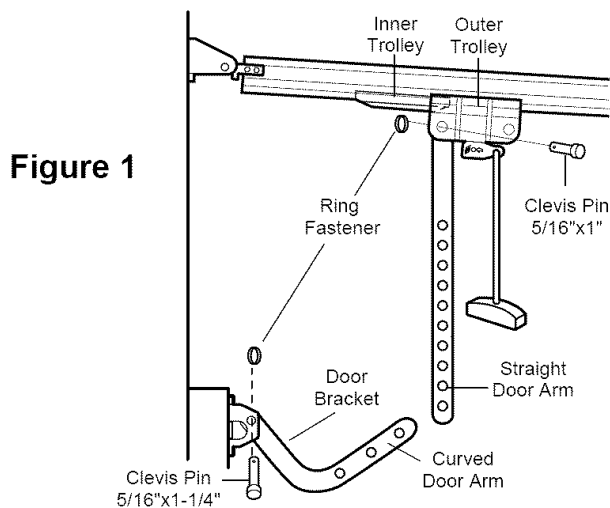
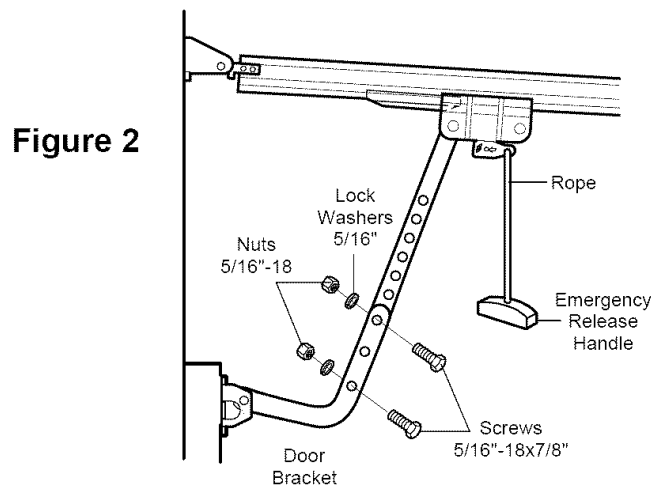

Figure 2:

- Bring arm sections together. Find two pairs of holes that line up and join sections. Select holes as far apart as possible to increase door arm rigidity.



### Hole Alignment Alternative

Figure 3:

- If holes in curved arm are *above* holes in straight arm, disconnect straight arm. Cut about 6" from the solid end. Reconnect to trolley with *cut end down* as shown.
- Bring arm sections together.
- Find two pairs of holes that line up and join with screws, lock washers and nuts.

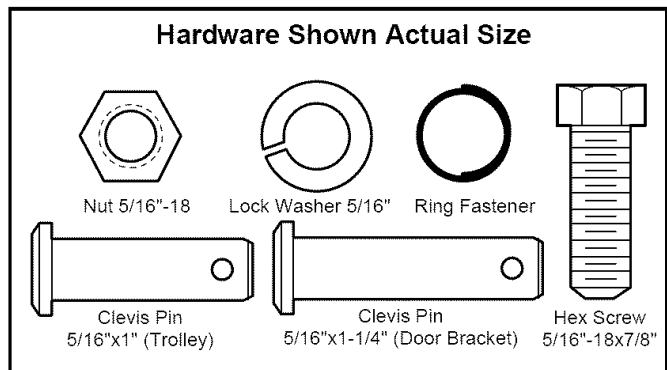
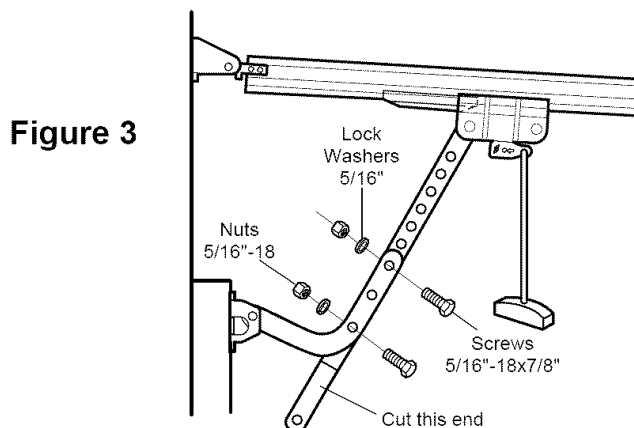

Proceed to Adjustment Step 1, page 28. Trolley will re-engage automatically when the opener is operated.

## All ONE-PIECE Doors

### Assemble the Door Arm:

- Fasten the straight and curved door arm sections together to the longest possible length (with a 2 or 3 hole overlap).
- With the door closed, connect the straight door arm section to the door bracket with the 5/16"x1-1/4" clevis pin.
- Secure with a ring fastener.

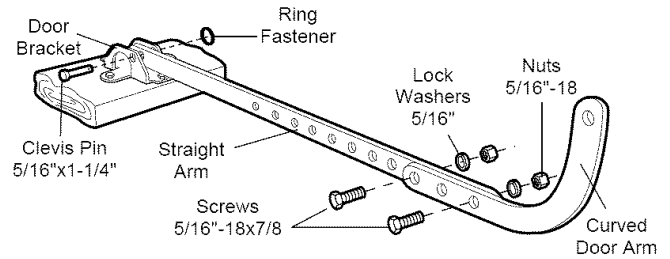

### Adjustment Procedures for One-Piece Doors

On one-piece doors, before connecting the door arm to the trolley the travel limits must be adjusted. Limit adjustment screws are located on the right side panel as shown on page 28. Follow adjustment procedures below.

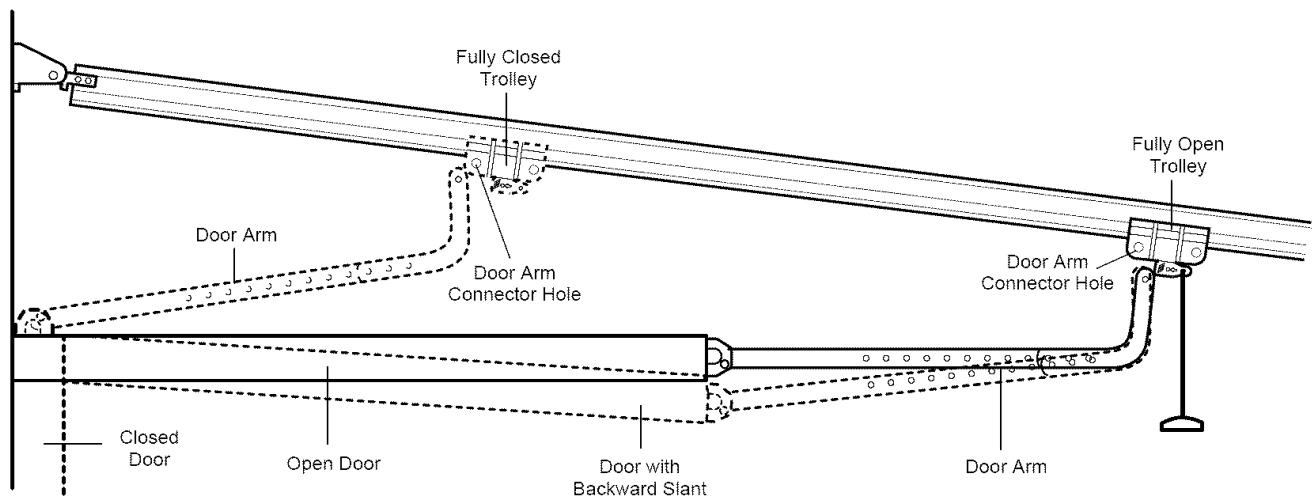

#### Open Door Adjustment: Decrease UP Travel Limit

- Turn the UP limit adjustment screw counter-clockwise 5 1/2 turns.
- Press the Door Control push button. The trolley will travel to the fully open position.
- Manually raise the door to the open position (parallel to the floor), and lift the door arm to the trolley. The arm should touch the trolley just in back of the door arm connector hole. Refer to the fully open trolley/door arm positions in the illustration. If the arm does not extend far enough, adjust the limit further. One full turn equals 2" of trolley travel.

#### Closed Door Adjustment: Decrease DOWN Travel Limit

- Turn the DOWN limit adjustment screw clockwise 5 complete turns.
- Press the Door Control push button. The trolley will travel to the fully closed position.
- Manually close the door and lift the door arm to the trolley. The arm should touch the trolley just ahead of the door arm connector hole. Refer to the fully closed trolley/door arm positions in the illustration. If the arm is behind the connector hole, adjust the limit further. One full turn equals 2" of trolley travel.

### Connect the Door Arm to the Trolley:

- Close the door and join the curved arm to the connector hole in the trolley with the remaining clevis pin. **It may be necessary to lift the door slightly to make the connection.**
- Secure with a ring fastener.
- Run the opener through a complete travel cycle. If the door has a slight "backward" slant in full open position as shown in the illustration, decrease the UP limit until the door is parallel to the floor.

## Adjustment Step 1

### Adjust the UP and DOWN Limits

Do not make any limit adjustments until the safety reversing sensors are completely installed.

Limit adjustment settings regulate the points at which the door will *stop* when moving up or down.

The door will *stop* in the *up* direction if anything interferes with door travel. The door will *reverse* in the *down* direction if anything interferes with the door travel (including binding or unbalanced doors).

To operate the opener, press the Door Control push button. Run the opener through a complete travel cycle.

- Does the door open and close completely?
- Does the door stay closed and not reverse unintentionally when fully closed?

If your door passes both of these tests, no limit adjustments are necessary unless the reversing test fails (see page 30).

Adjustment procedures are outlined below. **Run the opener through a complete travel cycle after each adjustment.**

*Repeated operation of the opener during adjustment procedures may cause the motor to overheat and shut off. Simply wait 15 minutes and try again.*

Read the procedures carefully before proceeding to Adjustment Step 2. Use a screwdriver to make limit adjustments.



## WARNING

Improper adjustment of the travel limits will interfere with the proper operation of the safety reverse system. *The door might not reverse properly when required and could seriously injure or kill someone under it. Test the safety reverse system monthly, and following all adjustments to the travel limits. See page 30.*

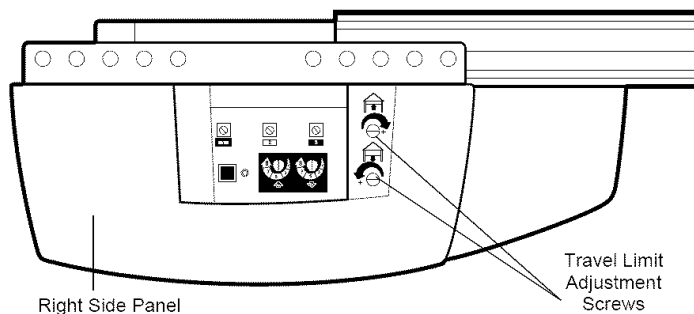

LIMIT ADJUSTMENT LABEL

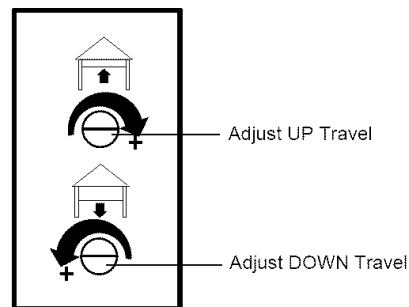

## How and When to Adjust the Limits

**If the door does not open completely but opens at least five feet:**

Increase *up* travel. Turn the UP limit adjustment screw clockwise. One turn equals 2" of travel.

**If door does not open at least 5 feet:**

Adjust the UP (open) force as explained in Adjustment Step 2.

**If the door does not close completely:**

Increase *down* travel. Turn the DOWN limit adjustment screw counterclockwise. One turn equals 2" of travel.

If door still won't close completely, try lengthening the door arm (see page 26).

If you have adjusted the door arm to the maximum length and the door still will not close completely, lower the header bracket. See Installation Step 1, pages 12 and 13.

**If the opener reverses in fully closed position:**

Decrease *down* travel. Turn the DOWN limit adjustment screw clockwise. One turn equals 2" of travel.

**If the door reverses when closing and there is no visible interference to travel cycle:**

If the opener lights are flashing, the Safety Reversing Sensors are either not installed, misaligned, or obstructed. See Troubleshooting, page 22.

Test the door for binding: Pull the emergency release handle. Manually open and close the door. If the door is binding, call for garage door service. If the door is not binding or unbalanced, adjust the DOWN (close) force. See Adjustment Step 2.

## Adjustment Step 2

### Adjust the Force

Force adjustment controls are located on the right panel of the opener. Force adjustment settings regulate the amount of power required to open and close the door.

The door will *stop* in the *up* direction if anything interferes with its travel. The door will *reverse* in the *down* direction if anything interferes with its travel (including binding or unbalanced doors).

If the forces are set too light, door travel may be interrupted by *nuisance reversals* in the *down* direction and *stops* in the *up* direction. Weather conditions can affect the door movement, so occasional adjustment may be needed.

The maximum force adjustment range is about 3/4 of a complete turn. Do not force controls beyond that point. Turn force adjustment controls with a screwdriver.

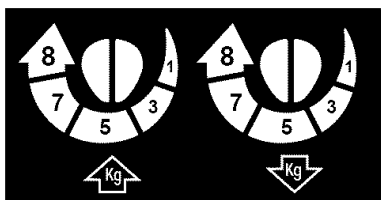

Force Adjustment Label

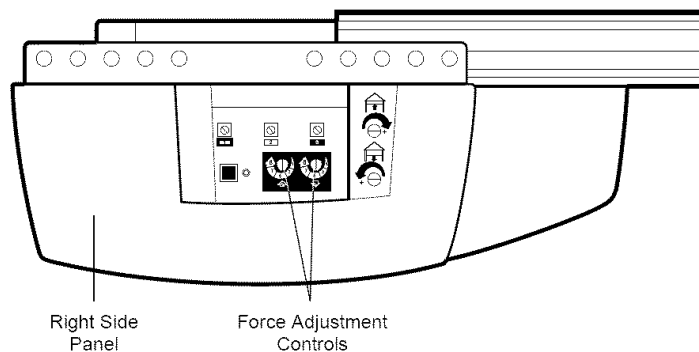

## WARNING

Too much force on the door will interfere with the proper operation of the safety reverse system. *The door might not reverse properly when required and could seriously injure or kill someone under it.* Do not increase the force beyond the minimum amount required to close the door. Do not use the force adjustments to compensate for a binding or sticking garage door. Test the safety reverse system monthly, and following all adjustments to force levels. See page 30.

## How and When to Adjust the Forces

### Test the DOWN (close) force

Grasp the door bottom when the door is about halfway through DOWN (close) travel. The door should reverse.

***Reversal halfway through down travel does not guarantee reversal on a one-inch obstruction. See page 30.*** If the door is hard to hold or doesn't reverse, decrease the DOWN (close) force by turning the control counterclockwise.

Make small adjustments until the door reverses normally. After each adjustment, run the opener through a complete cycle.

### Test the UP (open) force

Grasp the door bottom when the door is about halfway through UP (open) travel. The door should stop. If the door is hard to hold or doesn't stop, decrease UP (open) force by turning the control counterclockwise.

Make small adjustments until the door stops easily. After each adjustment, run the opener through a complete travel cycle.

### If the door doesn't open *at least 5 feet*:

Increase UP (Open) force by turning the control clockwise. Make small adjustments until door opens completely. Readjust the UP limit if necessary. After each adjustment, run the opener through a complete travel cycle.

### If the door *reverses* during the down (close) cycle and the opener lights aren't flashing:

Increase DOWN (close) force by turning the control clockwise. Make small adjustments until the door completes a close cycle. After each adjustment, run the opener through a complete travel cycle. **Do not increase the force beyond the minimum amount required to close the door.**

## Adjustment Step 3

### Test the Safety Reversing Sensor

- Press the remote control push button to open the door.
- Place the opener carton in the path of the door.
- Press the remote control push button to close the door.  
*The door will not move more than an inch, and the opener light will flash for 5 seconds.*

**Professional service is required if the opener closes the door when the safety reversing sensor is obstructed.**

**The garage door opener will not close from a remote if the indicator light in either sensor is off (alerting you to the fact that the sensor is misaligned or obstructed).**

The garage door can be closed by pressing and *holding* the Door Control push button until down travel is completed.

**WARNING**

*Without a properly working safety reversing sensor, persons (particularly children) could be seriously injured or killed if trapped by a closing garage door. Repeat this test once a month.*

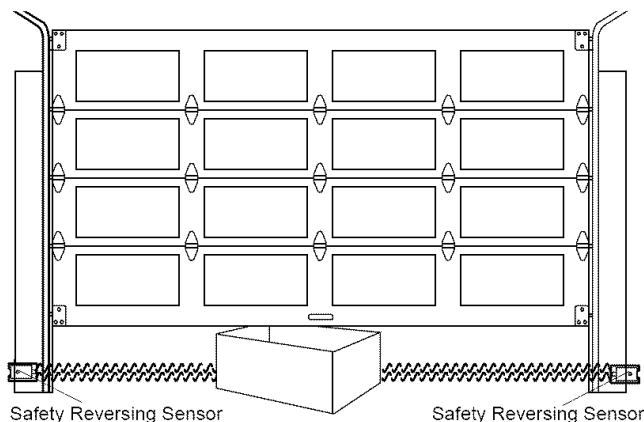

## Adjustment Step 4

### Test the Safety Reverse System

#### Test

- Place a one-inch board (or a 2x4 laid flat) on the floor, centered under the garage door.
- Operate the door in the down direction. ***The door must reverse on striking the obstruction.***

#### Adjustment

If the door *stops* on the obstruction, it is not traveling far enough in the down direction.

- Increase the DOWN limit by turning the DOWN limit adjustment screw counterclockwise 1/4 turn.
- Repeat the test.

**On a sectional door, make sure limit adjustments do not force the door arm beyond a straight up and down position. See the illustration on page 26.**

- When the door reverses on the one-inch board, remove the obstruction and run the opener through 3 or 4 complete travel cycles to test adjustment.

**If the door will not reverse after repeated adjustment attempts, call for professional garage door service.**

#### Important Safety Check

#### Repeat Adjustment Steps 1 – 4 after:

- Each adjustment of door arm length, force controls or limit controls.
- Any repair to or adjustment of the garage door (including springs and hardware).
- Any repair to or buckling of the garage floor.
- Any repair to or adjustment of the opener.

**WARNING**

*Failure to test and adjust the safety reverse system may result in serious injury or death to persons trapped by a closing garage door. Repeat this test once a month and adjust as needed.*

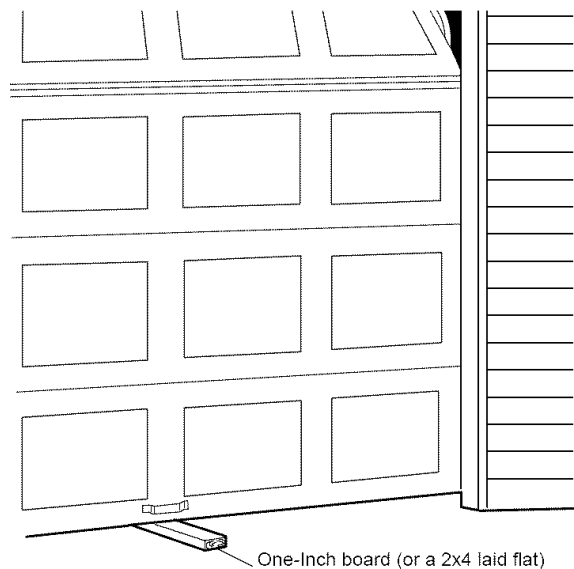

# IMPORTANT SAFETY INSTRUCTIONS



**WARNING**



**WARNING**

## To reduce the risk of severe injury or death to persons:

1. READ AND FOLLOW ALL INSTRUCTIONS.
2. Do not permit children either to operate or to play with the opener. Keep remote control in a location inaccessible to children.
3. Operate opener only when the door is in full view and free from any obstruction. Keep the door in sight until it is completely closed. **NO ONE SHOULD CROSS THE PATH OF THE MOVING DOOR.**
4. Check safety reversal system monthly. See page 30. The garage door **MUST** reverse on contact with a one inch object (or a 2x4 board laid flat) placed on the floor. If an adjustment is made to one of the controls (either force or limits of travel), the other control may need to be adjusted also, and the safety reversal system **must** be checked. *Failure to properly adjust the opener may result in severe injury or death.*
5. If possible, use the emergency release only when the door is in a closed position. Caution should be taken whenever the disconnect cord is actuated with the door open. *Weak or broken springs may cause the door to fall rapidly, causing injury or death to persons.*
6. **KEEP GARAGE DOORS PROPERLY BALANCED.** See page 3. *An improperly balanced door may not reverse when required, and could result in severe injury or death.* Repairs to cables, spring assemblies and other hardware must be made by a professional garage door person.
7. Disconnect the electric power to the garage door opener before making any repairs or removing the covers.

## SAVE THESE INSTRUCTIONS

### Care of Your Opener

#### Force and Limit Adjustment Controls

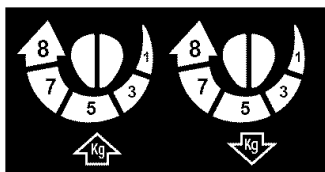

FORCE CONTROLS

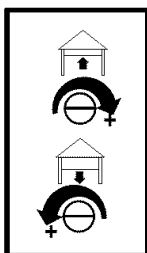

LIMIT CONTROLS

Weather conditions may cause some minor changes in door operation requiring some re-adjustments, particularly during the first year of operation.

Pages 28 and 29 refer to the limit and force adjustments. Only a screwdriver is required. Follow the instructions carefully.

Repeat the safety reverse test (page 30) after any adjustment of limits or force.

#### The remote control

The lithium batteries should produce power for up to 5 years. To replace batteries, use the visor clip or screwdriver blade to pry open the case, as shown. ("Open" location is stamped on back of remote control case.) Insert batteries *positive side down*.

3-FUNCTION  
Open this end  
first to avoid  
cracking  
housing

COMPACT  
Twist here  
to open

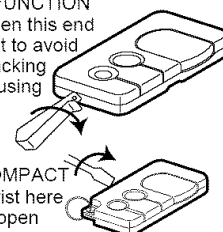

Replace cover as follows. *3-Function remote:* Insert the 3 tabs at the opposite end and snap shut. *Compact 3-Function remote:* Snap shut along both sides.

Dispose of old batteries properly.



**WARNING**

**Keep batteries away from small children. If swallowed, promptly notify doctor.**

### Maintenance Schedule

#### Once a Month

**Manually operate door.** If it is unbalanced or binding, call for professional garage door service.

**Check to be sure door opens and closes fully.** Adjust limits and/or force if necessary. (See pages 28 & 29.)

**Repeat the safety reverse test.** Make any necessary adjustments (See page 30).

#### Once a Year

**Oil door rollers, bearings and hinges.** The opener does not require additional lubrication. Do not grease the door tracks.

# Operation of Your Opener

Activate the opener with any of the following:

- **The Remote Control:** Hold push button down until the door starts to move.
- **The Door Control:** Hold push bar or button down until the door starts to move.
- **The Outdoor Key Switch or Keyless Entry:** (See Accessories)

When the opener is activated with the safety reversing sensor installed and correctly aligned:

1. If open, the door will close. If closed, the door will open.
2. If closing, the door will reverse.
3. If opening, the door will stop (allowing space for entry and exit of pets and for fresh air).
4. If the door has been stopped in a partially open position, it will close.
5. If obstructed while closing, the door will reverse.
6. If obstructed while opening, the door will stop.
7. The garage door will reverse in the closing cycle when the invisible beam is broken. If fully open, the door will not close when the beam is broken. The sensor has no effect in the opening cycle.

If the sensor is not installed, or is not aligned correctly, the door won't close from any remote control. You can close the door with the Door Control, the Outdoor Key Switch, or Keyless Entry, however, if you activate them *until down travel is complete*. If you release them too soon, the door will *reverse*.

The opener lights will *blink for 5 seconds* when the safety reversing sensor causes the door to reverse.

**The Opener Lights** will turn on under the following conditions: When the opener is initially plugged in; when the power is interrupted; when the opener is activated. They will turn off automatically after 4-1/2 minutes or provide constant light when the Light feature on the Premium Control Console is activated. **SECURITY+** models: Lights will also turn on when someone walks through the open garage door. Bulb size is 75 watts maximum.



## WARNING

*Weak or broken springs could allow an open door to fall (either rapidly or unexpectedly), resulting in serious injury, death or property damage. If possible, use the manual release rope and handle only when the door is fully closed.*

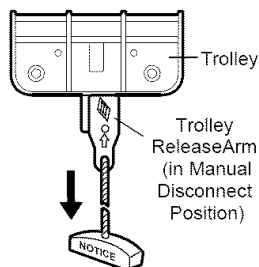

**Lockout position  
(Manual disconnect)**

### To open the door manually:

The door should be fully closed if possible. Pull down on the emergency release handle (so that the trolley release arm snaps into a vertical position) and lift the door manually. The **lockout feature** prevents the trolley from reconnecting automatically, and the door can be raised and lowered manually as often as necessary.

### To reengage the trolley:

Pull the emergency release handle toward the opener at a 45° degree angle so that the trolley release arm is horizontal. The trolley will reconnect on the next UP or DOWN operation, either manually or by pressing the Door Control push button.

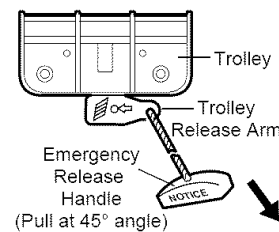

**To reconnect**

## Operation of the Door Controls (see page 21)

(**SECURITY+** models: See additional programming features, next page.)

Press the lighted push button to open or close the door. Press again to *reverse* the door during the closing cycle or to *stop* the door while it's opening.

### Premium Console:

**Light feature:** Press the large round Light button. If the opener light is *off*, it will turn *on*. If the opener light is *on*, (even in the 4-1/2 minute automatic cycle) it will turn *off*.

But if you use the Light button to turn the lights *on* and then activate the opener, the lights will turn *off* after 4-1/2 minutes.

The Light button will not control the opener lights when the door is in motion.

### Premium Console (cont.):

**Lock feature:** The Lock feature is designed to prevent operation of the door from remote controls. However, the door will *open and close* from the Door Control, the Outdoor Key Switch and the Keyless Entry Accessories.

**To activate:** Press and hold the small round Lock button for 2 seconds. The push button light will flash as long as the Lock feature is *on*.

**To turn off:** Press and hold the Lock button again for 2 seconds. The push button light will stop flashing. The Lock feature will also turn off whenever the SRT button on the opener panel is activated.



# Receiver and Remote Control Programming

## SECURITY+™

Your garage door opener receiver and remote control have been pre-set at the factory. The door will open when you press the LARGE remote control push button. The code between the remote control and the receiver changes with each use, randomly accessing over 100 billion new codes.

The 3-function remote control can also activate additional SECURITY+ garage door openers and/or light controls.

Your SECURITY+ opener will operate with:

- several SECURITY+ remote controls (with blue push buttons) utilizing up to 8 functions.
- one SECURITY+ Keyless Entry System (Model 139.53684).

Follow the instructions below to program your opener to match any additional remotes you may purchase. See Accessories on page 38.

### To Add A Remote Control

*If you have a Premium Control Console:*

1. *With the door closed*, press and hold a remote control push button. See Figure 1.
2. Press and hold the Light button on the door control.
3. Press and hold the door control push button.
4. After the opener light flashes, release all buttons.

Test by pressing the remote push button.

*If you do not have a Premium Control Console:*

1. Press and *hold* the selected remote control push button. See Figure 1.
2. Then press and release the SRT (learn) button on the back panel of the opener, Figure 2. The indicator light on the panel will begin to blink and the opener light will *flash once*.
3. Release the remote push button.

Test by pressing the remote push button.

### To Erase All Remote Control Codes

Press and hold the SRT button on the opener panel until the indicator light turns off (about 6 seconds). All remote control codes are now erased. Then follow the steps above to re-program each remote control.

To comply with FCC rules, adjustment or modifications of this receiver and/or transmitter are prohibited, except for changing the code setting or replacing the battery. THERE ARE NO OTHER USER SERVICEABLE PARTS.



## WARNING

Children operating or playing with a garage door opener can injure themselves or others. **The garage door could close and cause serious injury or death. Do not allow children to operate the door push button(s) or remote control(s).**

**A moving garage door could injure or kill someone under it. Activate the opener only when you can see the door clearly, it is free of obstructions, and is properly adjusted.**

Figure 1

Select a remote control push button to operate opener



SECURITY+  
3-Function  
Remote Control

Figure 2

SECURITY+  
Garage Door Opener

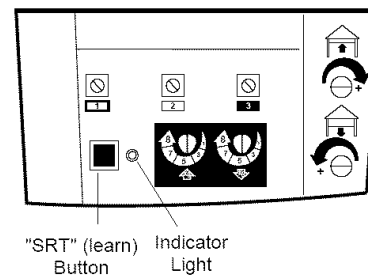

### To Control the Opener Light (Premium Consoles)

With SECURITY+ remote controls, a push button can be programmed to operate the opener light without opening the door.

1. *With the door closed*, press and hold the remote button that you want to control the light.
2. Press and hold the Light button on the door control.
3. Press and hold the Lock button on the door control.
4. After the opener light flashes, release all buttons.

Test by pressing the remote push button. The opener light should turn on or off but the door should not move.

# Troubleshooting

## Situation

## Probable Cause & Solution

*The opener doesn't operate from either the door control or the remote control:*

1. Does the opener have electric power? Plug a lamp into the outlet. If it doesn't light, check the fuse box or the circuit breaker. (Some outlets are controlled by a wall switch.)
2. Have you disabled all door locks? Review installation instruction warnings on Page 11.
3. Is there a build-up of ice or snow under the door? The door may be frozen to the ground. Remove any restriction.
4. The garage door spring may be broken. Have it replaced.
5. Repeated operation may have tripped the overload protector in the motor. Wait 15 minutes. Try again.

*Opener operates from the remote control, but not from the door control:*

1. Is the door control push bar lit? If not, Remove the bell wire from the opener terminal screws. Short the red and white terminals by touching both terminals at the same time with a piece of wire. If the opener runs, check for a faulty wire connection at the door control, a short under the staples, or a broken wire.
2. Are the wiring connections correct? Review Installation Step 7, page 21.

*The door operates from the door control, but not from the remote control:*

1. Is any door push button flashing? If your model has the Lock feature, make sure it is *off*.
2. Your opener needs to re-learn a remote control code. Refer to instructions on the opener panel.
3. Does the battery test light glow when the remote control push button is pressed? If not, replace the battery.
4. Program the receiver to match the remote control code.
5. Repeat the receiver programming procedure with all remote controls.

*The remote control has short range:*

1. Check the battery test light. If the light is dim, replace the battery.
2. Change the location of the remote control in your car.
3. Check to be sure the antenna on the right side panel of opener extends fully.
4. Some installations may have shorter range due to a metal door, foil backed insulation, or metal garage siding. (Antenna Extender Kit 41A3504)

*Opener noise is disturbing in living quarters of home:*

If operational noise is a problem because of proximity of the opener to the living quarters, the Vibration Isolator Kit 41A3263 can be installed. This kit was designed to minimize vibration to the house and is easy to install.

*The garage door opens and closes by itself:*

1. Be sure that all remote control push buttons and battery indicator lights are off.
2. Remove the bell wire from the door control terminals and operate from the remote control only. If this solves the problem, the door control is faulty (replace), or there is an intermittent short on the wire between the door control and the opener.
3. Clear memory and reprogram all remote controls.

*The door doesn't open completely:*

1. Is something obstructing the door? Remove the obstruction or repair the door.
2. If the door has been working properly but now doesn't open all the way, increase the *up force*. See page 29.
3. If door opens at least 5 feet, the travel limits may need to be increased. One turn equals 2 inches of travel. See page 28.

***Repeat the safety reverse test after the adjustment is complete.***

*The door stops but doesn't close completely:*

Review the travel limits adjustment procedures on page 28.

***Repeat the safety reverse test after any adjustment of door arm length, close force or down limit.***

## Troubleshooting (continued)

### Situation

### Probable Cause & Solution

---

*The door opens but won't close:*

1. If the opener lights blink, check the safety reversing sensor. See page 22.
  2. If the opener lights do not blink and it is a new installation, check the down force. See Adjustment Step 2, page 29. For an existing installation, see below.  
**Repeat the safety reverse test after the adjustment is complete.**
- 

*The door reverses for no apparent reason and opener lights don't blink:*

1. Is something obstructing the door? Pull the emergency release handle. Operate the door manually. If it is unbalanced or binding, call for professional garage door service.
  2. Clear any ice or snow from the garage floor area where the door closes.
  3. Review the force adjustment procedures on page 29.
  4. If door reverses in the *fully closed* position, decrease the travel limits (page 28).  
**Repeat the safety reverse test after adjustments to force or travel limits. The need for occasional adjustment of the force and limit settings is normal. Weather conditions in particular can affect door travel.**
- 

*The door reverses for no apparent reason and opener lights blink for 5 seconds after reversing:*

Check the safety reversing sensor. Remove any obstruction or align the receiving eye. See pages 12 and 22.

---

*The opener lights...*

**don't turn on:**

Replace the light bulb(s) (100 watts maximum). Use a *standard neck* garage door opener bulb if regular bulb burns out.

**don't turn off:**

Is the Light feature *on*? Turn it *off*.

---

*The opener strains or maximum force is needed to operate door:*

The door may be out of balance or the springs are broken. **Close the door** and use the emergency release handle to disconnect the trolley. Open and close the door manually. A properly balanced door will stay in any point of travel while being supported entirely by its springs. If it does not, disconnect the opener and call for professional garage door service.  
**Do not increase the force to operate the opener.**

---

*The opener motor hums briefly, then won't work:*

1. The garage door springs are broken. See above.
  2. If the problem occurs on the first operation of the opener, door may be locked. *Disable the door lock.*  
**Repeat the safety reverse test after the adjustment is complete.**
- 

*The opener won't operate due to power failure:*

1. Use the emergency release handle to disconnect the trolley. The door can be opened and closed manually. When power is restored, press the Door Control push button and trolley will automatically reconnect (unless trolley is in lockout position.) See page 32.
2. The Emergency Key Release accessory (for use on garages with no service door) disconnects the trolley from outside the garage in case of power failure.

# Repair Parts

## Rail Assembly Parts

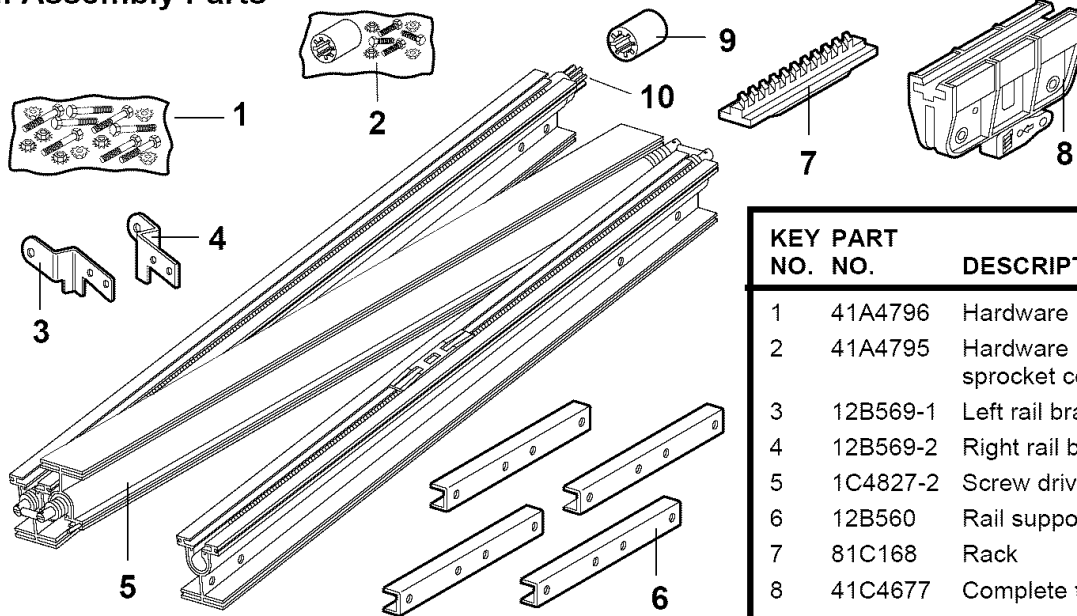

### KEY PART NO. NO.

### DESCRIPTION

1	41A4796	Hardware bag
2	41A4795	Hardware bag (includes sprocket coupling)
3	12B569-1	Left rail bracket
4	12B569-2	Right rail bracket
5	1C4827-2	Screw drive rail assembly
6	12B560	Rail support brace
7	81C168	Rack
8	41C4677	Complete trolley assembly
9	25A18	Sprocket coupling
10	41A4836	Drive sprocket kit

## Installation Parts

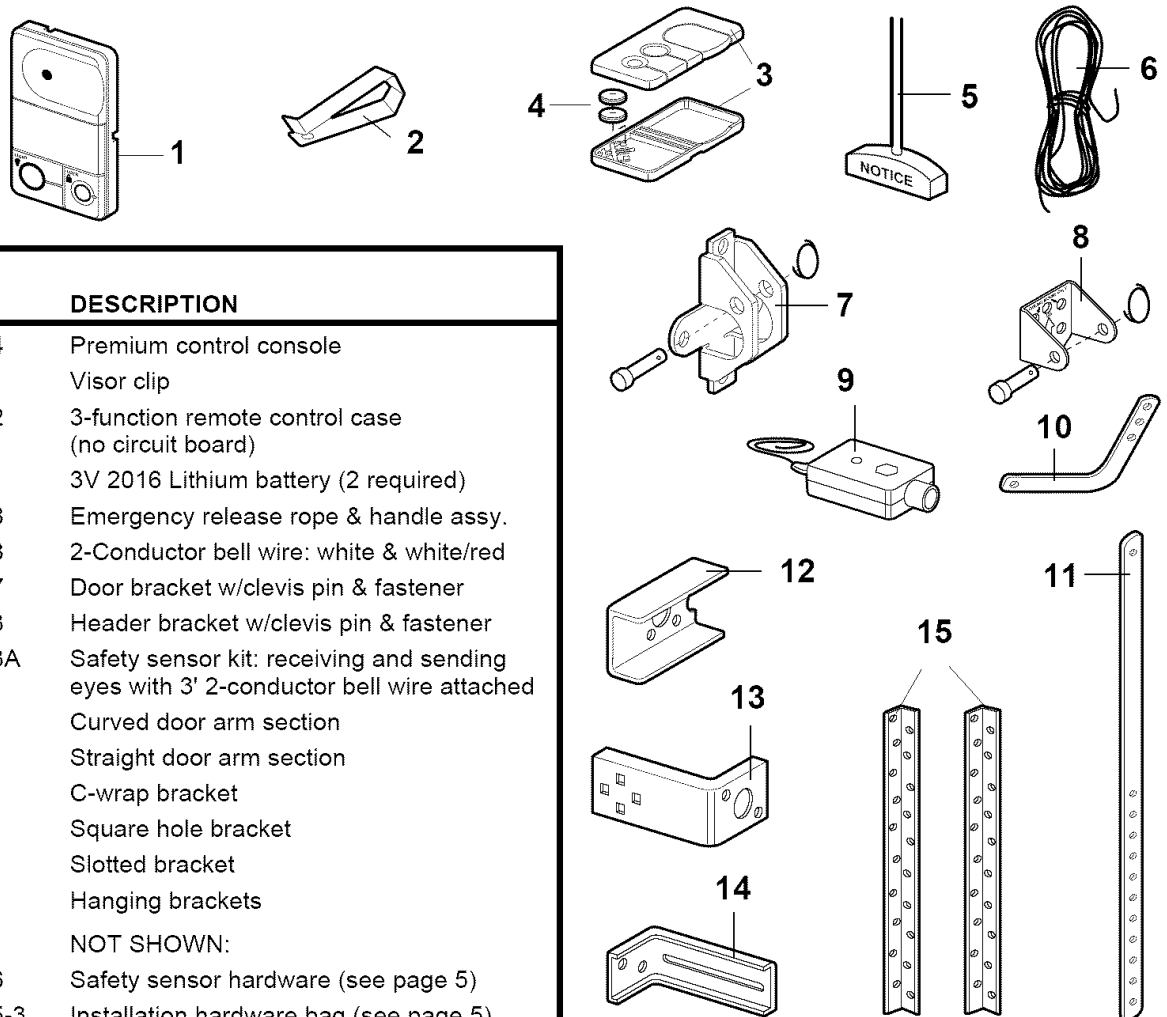

KEY NO.	PART NO.	DESCRIPTION
1	41A4884	Premium control console
2	29B134	Visor clip
3	41A5032	3-function remote control case (no circuit board)
4	10A19	3V 2016 Lithium battery (2 required)
5	41A2828	Emergency release rope & handle assy.
6	217A238	2-Conductor bell wire: white & white/red
7	41A5047	Door bracket w/clevis pin & fastener
8	41A4353	Header bracket w/clevis pin & fastener
9	41A4373A	Safety sensor kit: receiving and sending eyes with 3' 2-conductor bell wire attached
10	178B35	Curved door arm section
11	178B34	Straight door arm section
12	12B483	C-wrap bracket
13	12B484	Square hole bracket
14	12B485	Slotted bracket
15	12B350	Hanging brackets
NOT SHOWN:		
	41A4116	Safety sensor hardware (see page 5)
	41A4675-3	Installation hardware bag (see page 5)
	114A2123	Owner's manual

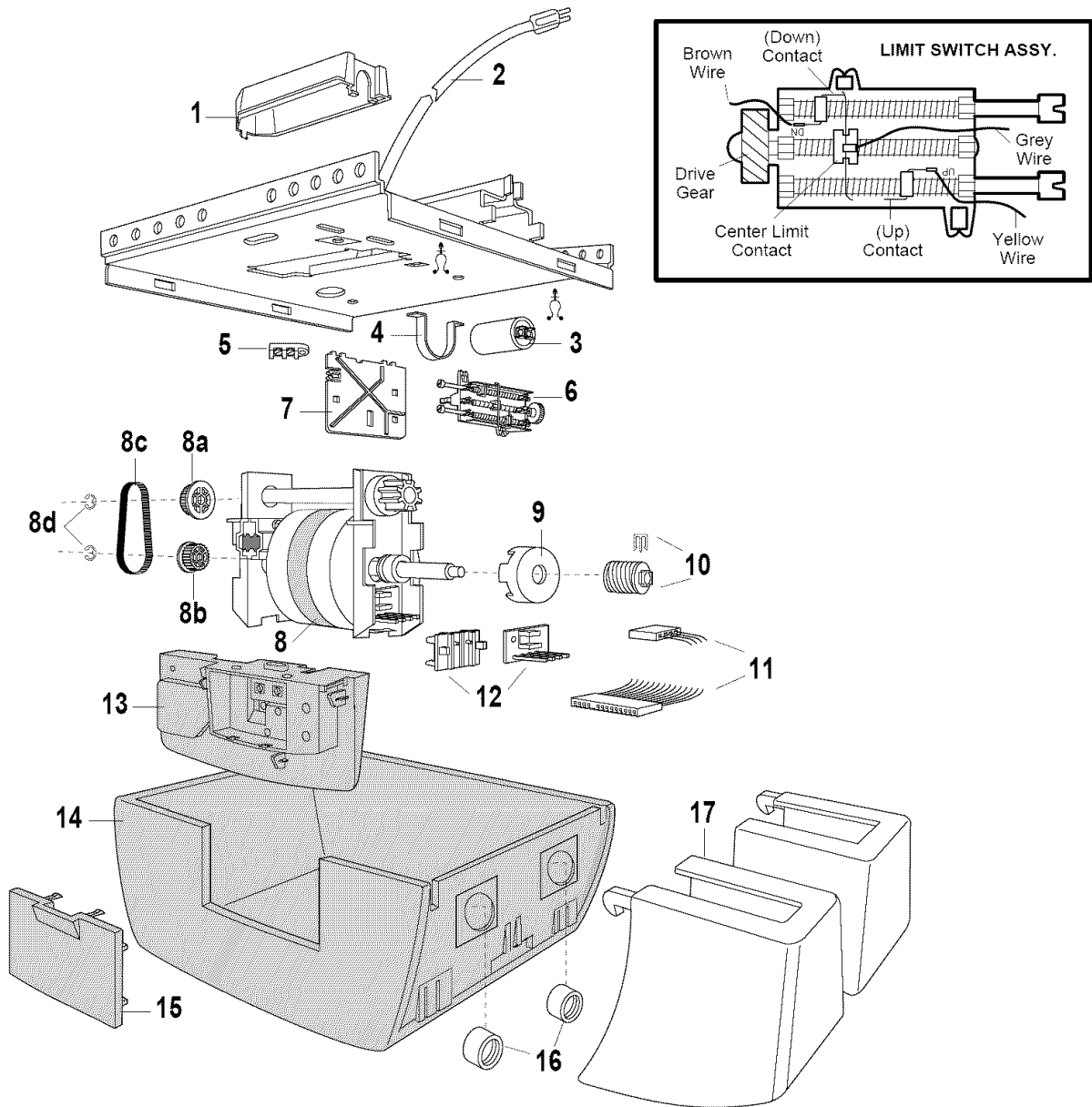

# Repair Parts

## Opener Assembly Parts

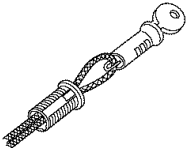
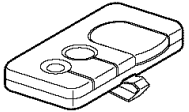
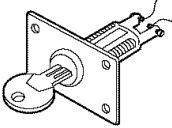
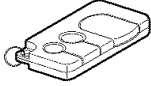
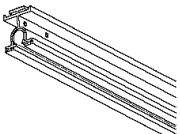
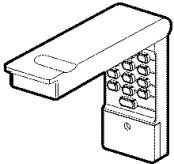
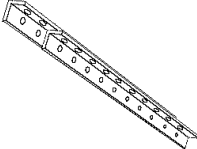

KEY NO.	PART NO.	DESCRIPTION	KEY NO.	PART NO.	DESCRIPTION
1	31D426	Drive shaft cover	9	41A4843	Interrupter cup
2	41B4245	Line cord	10	41A4837	Worm gear and retainer
3	30B363	Capacitor – 1/2 HP	11	41C4669	Wire harness assembly
4	12A373	Capacitor bracket	12	41C4672	RPM sensor assembly
5	41A3150	Terminal block w/screws	13	41D4674-11	Receiver logic board assembly
6	41D4671	Limit switch assembly	14	41D4839-7	Cover
7	12D554	Limit switch bracket	15	1C4840-6	Control Center access door
8	41D4759	Complete Motor Drive Assy., with	16	175C123	Light socket
8a	144B41	22T Pulley	17	108D47	Light lens
8b	144B42	28T Pulley			
8c	20C14	Drive Belt			
8d	158A69	Retainer Ring			

# Accessories Available For Your Opener

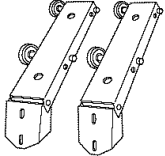
<p><b>139.53702</b></p> 	<p><b>Emergency Key Release:</b>  <i>Required</i> for a garage with NO access door. Enables homeowner to open garage door manually from outside by disengaging trolley.</p>	<p><b>139.53681</b></p> 	<p><b>SECURITY+ 3-Function Remote Control:</b>          Includes visor clip.</p>
<p><b>139.53703</b></p> 	<p><b>Outdoor Key Switch:</b>          Operates the garage door automatically from outside when remote control is not handy.</p>	<p><b>139.53680</b></p> 	<p><b>SECURITY+ Compact 3-Function Remote Control:</b>          With loop for attaching key ring.          (Available April 1997)</p>
<p><b>139.53404</b></p> 	<p><b>8 Foot Rail Extension</b>          To allow an 8 foot door to open fully.</p>	<p><b>139.53684</b></p> 	<p><b>SECURITY+ Keyless Entry:</b>          Enables homeowner to operate garage door opener from outside by entering a password. Also can add a temporary password for visitors or service persons. This temporary password can be limited to a programmable number of hours or entries.</p>
<p><b>53885</b></p> 	<p><b>Support Brackets:</b>          For finished ceilings or where additional support is required, based on garage construction. Includes brackets and fastening hardware.</p>	<p><b>139.53686</b></p> 	<p><b>Plug-In Light Control:</b>          Enables homeowner to turn on a lamp, television or other appliance from car, bedside, or anywhere in the home with a remote. Available April 1997.</p>
<p><b>139.53709</b></p> 	<p><b>Door Clearance Brackets:</b>  <i>(For Sectional Doors Only)</i>          Replaces top brackets and rollers on door to reduce height of door travel. For use when installing opener in garage with low headroom clearance.</p>		

## To Add the Keyless Entry

We recommend that you program your password before you install the Keyless Entry. You will not need assistance, and you can test the reception at the mounting location before installation.

### *If you have a Premium Control Console:*

1. *With the door closed*, press the four digit password desired, then press and hold Enter.
2. Press and hold the light button on the door control.
3. Press and hold the door control push bar.
4. After the opener light flashes, release all buttons.

### *If you do not have a Premium Control Console:*

1. Choose a 4-digit password using numbers from 0 to 9 (a number can be used more than once, for example, 4, 0, 4, 1).
2. Press the four buttons for the password, then press and *hold* the Enter button. The indicator light on the door opener panel will blink.
3. Press and release the SRT (learn) button on the opener panel. After the opener light flashes, release the Enter button.

Test by pressing the password, then press Enter. The door should begin to move.

# Index

<b>Access Door/Emergency Key Release Accessory</b> .....	6, 7, 35, 36
<b>Electrical Safety Warnings</b> .....	2, 22, 31
<b>Garage Door</b>	
Testing for balance, binding and sticking.....	3, 28, 31
Determining high point of travel:	
Sectional door.....	12
One-piece door .....	13
Disabling existing locks .....	3, 11
Force controls	
Adjustment procedures.....	29
Problems that might require force adjustments.....	34, 35
Safety warnings.....	29, 31
Door hardware.....	3, 11, 12, 31, 32
Maintenance .....	11, 28-31
Reinforcement requirements .....	4, 24, 25
Removing of all ropes .....	3, 11
Possible door damage.....	3, 19, 24
Travel limits	
Adjustment procedures.....	27, 28
Problems that might require limit adjustments .....	34, 35
Safety warnings.....	28, 31
<b>Emergency Release Rope &amp; Handle</b>	
Lockout feature .....	32
Manual disconnect.....	32, 35
Safety warnings .....	11, 23, 31, 32
<b>Opener Terminals</b>	
Door control connections .....	21
Safety reversing sensor connections.....	21, 22
<b>Receiver &amp; Remote Controls</b>	
Programming the receiver .....	33
Erasing all codes.....	33
Safety warning.....	33
Problems with remote control transmitter operation.....	34
<b>Safety Reversing Sensor</b> .....	16-18, 30
<b>Safety Reverse Test Procedure</b> .....	30
Testing required.....	11, 30, 34, 35
Safety reverse system problems	
Securing header bracket to wall .....	12
Adjusting travel limits.....	28
Applying excessive force on the door .....	29
Buckling or uneven floor.....	4, 5
<b>Safety Warnings</b> .....	2, 3, 11, 12, 16, 19, 20, 21, 22, 23, 24, 28, 29, 30, 31, 32, 33
<b>Troubleshooting</b> .....	34, 35
<b>User Instruction Label for Garage Wall</b> .....	11, 21
<b>Vibration Noise (isolator kit)</b> .....	34

**For professional installation**  
Call 24 hours a day, 7 days a week  
**1-800-865-6500**

**For the repair or replacement parts you need**  
Call 7 am – 7 pm, 7 days a week  
**1-800-366-PART**  
**(1-800-366-7278)**

**For in-home major brand repair service**  
Call 24 hours a day, 7 days a week  
**1-800-4-REPAIR**  
**(1-800-473-7247)**

**For the location of a Sears Repair Service Center in your area**  
Call 24 hours a day, 7 days a week  
**1-800-488-1222**

**For information on purchasing a Sears Maintenance Agreement  
or to inquire about an existing Agreement**  
Call 9 am – 5 pm, Monday-Saturday  
**1-800-827-6655**

**The model number label is located under the light lens on the  
front end panel of your opener. When requesting service or  
ordering parts, always give the following information:**

- Product Type
- Model Number
- Part Number
- Part Description

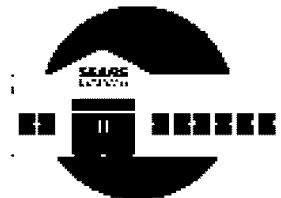
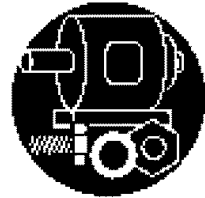

*America's Repair Specialists*

### **SEARS WARRANTY**

#### **FULL 90-DAY WARRANTY ON GARAGE DOOR OPENER**

For 90 days from the date of purchase, Sears will repair this Garage Door Opener, free of charge, if defective in material or workmanship.

#### **LIMITED WARRANTY**

From the 91st day until one year from the date of purchase, Sears will furnish replacement parts for any defective parts, free of charge. You pay for labor.

#### **LIMITED WARRANTY ON MOTOR**

**1/2HP MOTOR:** After 1 year and through 5 years, if the motor on this Garage Door Opener is defective, Sears will furnish a replacement motor, free of charge. You pay for labor.

#### **LIMITATION ON LIABILITY**

**SEARS WILL NOT BE LIABLE FOR LOSS OR DAMAGE TO PROPERTY OR ANY INCIDENTAL OR CONSEQUENTIAL LOSS OR EXPENSE FROM PROPERTY DAMAGE DUE DIRECTLY OR INDIRECTLY FROM THE USE OF THIS PRODUCT.** Some states do not allow the exclusion or limitation of incidental or consequential damages, so the above limitation or exclusion may not apply to you.

This warranty does not cover light bulbs or repair parts necessary because of operator abuse or negligence, including the failure to install, adjust and operate this garage door opener according to instructions contained in the owner's manual.

WARRANTY SERVICE IS AVAILABLE BY SIMPLY CONTACTING THE NEAREST SEARS CENTER/DEPARTMENT IN THE UNITED STATES.

This warranty applies only while this product is in use in the United States.

This warranty gives you specific legal rights, and you may also have other rights which vary from state to state.

**Sears, Roebuck and Co., Dept. 817WA, Hoffman Estates, IL 60179**