



### WARNING

Close door and disconnect power to the garage door opener before proceeding.

*The trolley must be in down (closed door) position during assembly and installation.* If you have a completely installed garage door opener, the rail/opener assembly must be taken down. UP and DOWN Limits must be readjusted after installation.

Opener hanging brackets will require repositioning due to increased rail length.

*If this is a new installation,* replace the front (header) rail in your opener carton with the longer one in this kit. Add the center rail in this kit as the second or third rail, creating a four rail assembly. Use the belt assembly and longer emergency release rope in this kit in place of those packaged with your opener. Complete the assembly, installation, and adjustment of your opener according to your Owner's Manual.

*If this is an existing installation, continue as follows:*

1. Pull down on the emergency release handle, then disconnect the trolley from the door arm.
2. Disconnect the rail/opener assembly from the header bracket and hanging brackets, and place it on the floor.
3. Remove the belt cap retainer from the opener sprocket and set aside.
4. Disconnect the master link from the trolley threaded shaft and belt; discard.
5. Remove the spring/nut from the trolley and discard.
6. Remove idler pulley assembly and set aside.
7. Remove the belt assembly and discard.
8. Remove the 1/4"-20x1-3/4 bolt and lock nut from the trolley stop hole (see Figure 1) in the front rail and set aside.
9. Push the trolley back toward the opener head. Disconnect the front rail section by using a screwdriver tip to pry up the outer tab on each side of the rail, then slide it off the center rail. Discard the front rail.
10. Align the new front rail and center rails with the existing rail assembly, keeping the small holes along the same edge, and the cut out "window" at the front (header) end. Be sure to keep rails right side up: *the idler pulley bolt hole above the window is larger on top of the rail than on the bottom.* Slide the new center rail onto the assembly; then add the front rail. Tabs along the side will lock into place.
11. As a temporary trolley stop, clamp a locking pliers onto the rail, 8" from the center of the idler pulley hole, as shown in Figure 2. Slide the trolley assembly to this point.
12. Lay the new belt beside the rail as shown in Figure 3. Grasp the end with the hooked trolley connector and

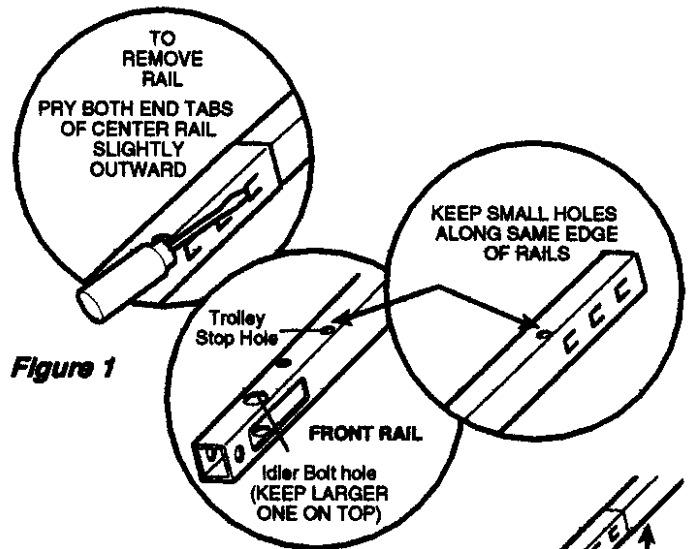

Figure 1

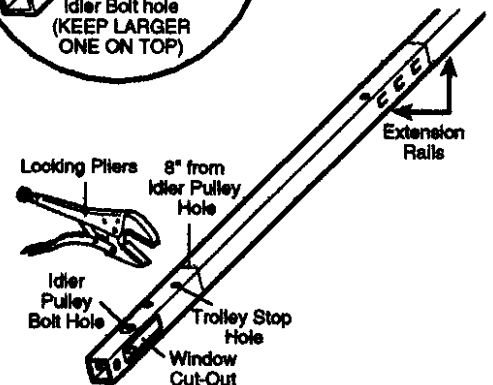
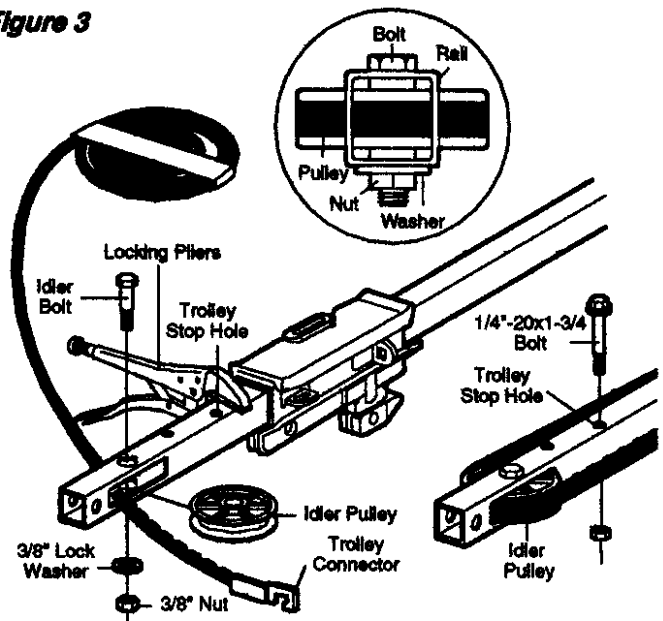

Figure 2

Figure 3



pass approximately 12" of belt through the window, keeping the ribbed side toward the rail. Allow it to hang while you complete the next two steps.

13. Replace the idler pulley, lock washer and nut. Rotate it to be sure it spins freely. Grease the center if necessary.
14. Replace the the 1/4"-20x1-3/4 bolt and lock nut into the trolley stop hole.

15. Pull the belt around the idler pulley and hook the trolley connector into the retaining slot on the trolley as shown in Figure 4. *The ribbed side must contact the pulley.*

16. With the trolley against the pliers, dispense the remainder of the belt along the rail assembly toward the powerhead and around the sprocket. The sprocket teeth must engage the belt.

17. Check to make sure the belt is not twisted, then connect it to the flat end of the trolley threaded shaft with the master link, as shown:

- Push pins of master link bar through holes in end of belt and trolley threaded shaft.
- Push master link cap over pins and past pin notches.
- Slide clip-on spring over cap and onto pin notches until both pins are securely locked in place.

18. Insert the trolley threaded shaft through the hole in the trolley. *Be sure the belt is not twisted, and the ribbed side faces the rail.*

19. Hold the belt at the trolley shaft as you thread the spring nut by hand (Figure 5) onto the shaft until finger tight against the trolley. *Do not use any tools.*

20. Remove the locking pliers.

21. Set the belt tension:

- Insert a screwdriver tip into one of the nut ring slots and brace it firmly against the trolley, as shown.
- Place a 7/16" open end wrench on the square end. Rotate the nut about 1/4 turn until the spring releases and snaps the nut ring against the trolley, Figure 6.

This sets the spring to optimum belt tension.

22. Replace the belt cap retainer and complete the re-installation and adjustment of your opener according to your owner's manual.

23. Replace the old emergency release rope with the new, longer replacement rope.

24. Reconnect power and operate the door in the UP direction.

25. Increase the UP travel limit by turning the UP limit adjustment screw in a clockwise direction as shown on label. One turn equals 2" of travel.

Figure 4

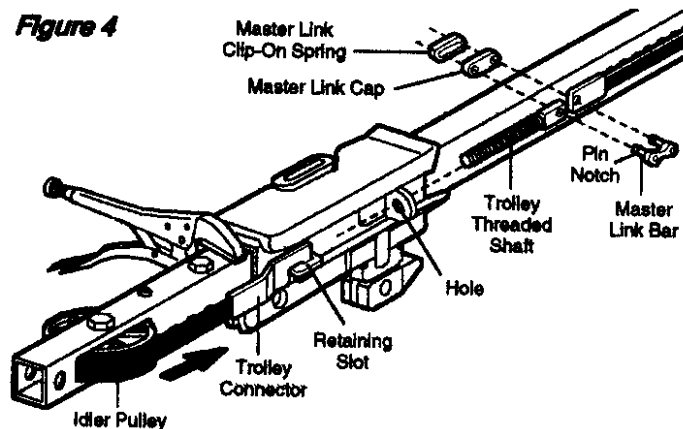

Figure 5

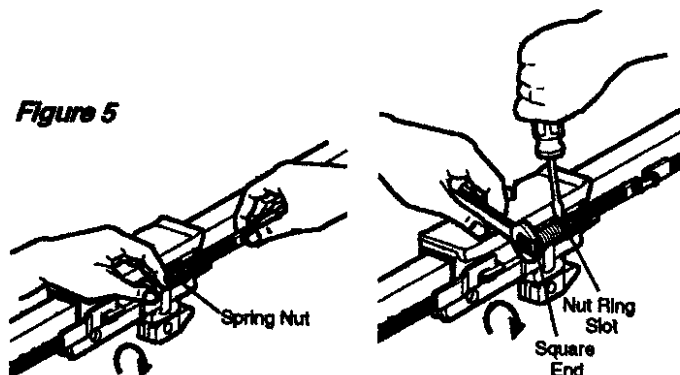
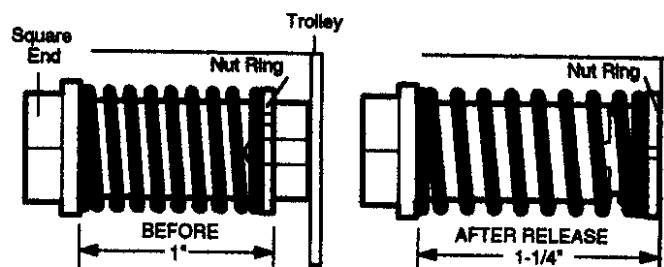

Figure 6



Part No.	Description	Qty
183C158-11	.Header rail extension	1
183C157-8	.Center rail extension	1
1A5250-2	.10' Belt Assembly	1
26A53	.Rope	1
1A995	.Master Link Kit	1
1A5019	.Spring Nut Assembly	1